

**SYSMAC
CXONE-AL□□D-V4**

CX-Motion-NCF Ver. 1.9

OPERATION MANUAL

OMRON

NOTE

All rights reserved. No part of this publication may be reproduced, stored in a retrieval system, or transmitted, in any form, or by any means, mechanical, electronic, photocopying, recording, or otherwise, without the prior written permission of OMRON.

No patent liability is assumed with respect to the use of the information contained herein. Moreover, because OMRON is constantly striving to improve its high-quality products, the information contained in this manual is subject to change without notice. Every precaution has been taken in the preparation of this manual. Nevertheless, OMRON assumes no responsibility for errors or omissions. Neither is any liability assumed for damages resulting from the use of the information contained in this publication.

Trademarks

- Microsoft, Windows, and Windows Vista are either registered trademarks or trademarks of Microsoft Corporation in the United States and other countries.
- MECHATROLINK is a registered trademark of the MECHATROLINK Members Association.
- VS-FlexGrip Pro
Copyright (C) 2000 VideoSoft Corporation
- ODVA, CIP, CompoNet, DeviceNet, and EtherNet/IP are trademarks of ODVA.

Other company names and product names in this document are the trademarks or registered trademarks of their respective companies.

Copyrights

Microsoft product screen shots reprinted with permission from Microsoft Corporation.

CXONE-AL□□D-V4

CX-Motion-NCF Ver. 1.9

Operation Manual

Revised April 2016

Notice:

OMRON products are manufactured for use according to proper procedures by a qualified operator and only for the purposes described in this manual.

The following conventions are used to indicate and classify precautions in this manual. Always heed the information provided with them. Failure to heed precautions can result in injury to people or damage to property.

 **DANGER** Indicates an imminently hazardous situation which, if not avoided, will result in death or serious injury. Additionally, there may be severe property damage.

 **WARNING** Indicates a potentially hazardous situation which, if not avoided, could result in death or serious injury. Additionally, there may be severe property damage.

 **Caution** Indicates a potentially hazardous situation which, if not avoided, may result in minor or moderate injury, or property damage.

OMRON Product References

All OMRON products are capitalized in this manual. The word “Unit” is also capitalized when it refers to an OMRON product, regardless of whether or not it appears in the proper name of the product.

The abbreviation “Ch,” which appears in some displays and on some OMRON products, often means “word” and is abbreviated “Wd” in documentation in this sense.

The abbreviation “PLC” means Programmable Controller.

Visual Aids

The following headings appear in the left column of the manual to help you locate different types of information.

Note Indicates information of particular interest for efficient and convenient operation of the product.

1,2,3... 1. Indicates lists of one sort or another, such as procedures, checklists, etc.

TABLE OF CONTENTS

PRECAUTIONS	xix
1 Intended Audience	xx
2 General Precautions	xx
3 Safety Precautions	xx
4 Operating Environment Precautions	xxi
5 Application Precautions	xxi
SECTION 1	
CX-Motion-NCF Overview	1
1-1 What is CX-Motion-NCF?	2
1-2 System Configuration	4
1-3 Function List	4
1-4 Operation Procedure	6
SECTION 2	
Setup	7
2-1 Installing and Uninstalling the Software	8
2-2 Connecting to PLC	8
SECTION 3	
Basic Operation	13
3-1 Screen Name	14
3-2 Basic Operation	17
3-3 Operations Listed by Purpose	24
SECTION 4	
Creating Projects	27
4-1 Creating a New Project	28
4-2 Adding and Deleting Position Control Units	29
4-3 Adding and Deleting Servo Drives	30
SECTION 5	
Editing Data	33
5-1 Editing Unit Parameters	34
5-2 Editing Servo Parameters	39

TABLE OF CONTENTS

SECTION 6

Saving and Reading Projects	43
6-1 Saving Project	44
6-2 Reading Project	44
6-3 Import	45
6-4 Export	45
6-5 Print	46

SECTION 7

Transferring and Comparing Data	49
7-1 Initial Setting for Connecting Online	50
7-2 Setting/Changing Communications Specific	50
7-3 Downloading Data	52
7-4 Uploading Data	57
7-5 Comparing Data	61
7-6 Writing to Flash Memory	66

SECTION 8

Monitor	69
8-1 Unit Monitor	70
8-2 Axis Monitor	73

SECTION 9

Test Run Operation	83
9-1 Test Run	84

SECTION 10

Absolute Encoder Setup	89
10-1 Absolute Encoder Setup	90

SECTION 11

Error Log and Troubleshooting	91
11-1 Error Log	92
11-2 Error Codes	92
11-3 Troubleshooting	111

Index	115
--------------------	------------

Revision History	119
-------------------------------	------------

About this Manual:

This manual describes the installation, and operation of the CX-Motion-NCF software package and includes the sections described below. The CX-Motion-NCF runs on any OS that is supported by the CX-One. It is used to set and transfer data used by CS1W-NCF71/CS1W-NC471/CS1W-NC271/CJ1W-NCF71/CJ1W-NC471/CJ1W-NC271 Position Control Units (also referred to as NC Units), save and print the Position Control Unit data, and monitor the Position Control Unit's operating status.

Please read this manual carefully and be sure you understand the information provided before attempting to install or operate the CX-Motion-NCF. Be sure to read the precautions provided in the following section. Please read the following manuals carefully and be sure you understand the information provided before setting up or using an application for a Position Control Unit.

Name	Contents	Cat. No. (suffixes omitted)
SYSMAC CX-Motion-NCF Operation Manual	Describes the operating procedures for the CX-Motion-NCF	W436 (this manual)
SYSMAC CS1W-NCF71/ CS1W-NC471/CS1W-NC271/ CJ1W-NCF71/CJ1W-NC471/ CJ1W-NC271 Position Control Units Operation Manual	Describes the basic operation of the Position Control Units.	W426

For details on procedures for installing the CX-Motion-NCF from the CX-One FA Integrated Tool Package, refer to the *CX-One Setup Manual* provided with CX-One.

Cat. No.	Model	Name	Contents
W463	CXONE-AL□□D-V4	CX-One Setup Manual	Installation and overview of CX-One FA Integrated Tool Package.

Precautions provide general precautions for using the CX-Motion-NCF, Programmable Controller, and related devices.

Section 1 provides an overview of the CX-Motion-NCF, and describes the functions and system configuration required to operate the CX-Motion-NCF.

Section 2 provides information on installing the CX-Motion-NCF and CX-Server, and connecting to the PLC.

Section 3 describes each of the screens and basic operations.

Section 4 provides information on creating projects and adding/deleting Position Control Units and Servo Drives.

Section 5 describes the operations used to edit Unit Parameters and Servo Parameters.

Section 6 describes the operations used to save and read newly created projects. Information is also provided on importing, exporting, and printing procedures.

Section 7 describes the operations used to transfer or compare data between the personal computer and Position Control Unit/Servo Drive, and to write data transferred to the Position Control Unit to the Position Control Unit's flash memory.

Section 8 provides information on the Monitor Windows that are used to display the Position Control Unit's communications status, error status, and axis's present position and status.

Section 9 describes the test run operation for each axis.

Section 10 describes the absolute encoder setup operation.

Section 11 provides information on troubleshooting errors that may occur, meanings of error codes, and the procedures required to reset errors in the Unit or axes.



WARNING Failure to read and understand the information provided in this manual may result in personal injury or death, damage to the product, or product failure. Please read each section in its entirety and be sure you understand the information provided in the section and related sections before attempting any of the procedures or operations given.

Terms and Conditions Agreement

WARRANTY

- The warranty period for the Software is one year from the date of purchase, unless otherwise specifically agreed.
- If the User discovers defect of the Software (substantial non-conformity with the manual), and return it to OMRON within the above warranty period, OMRON will replace the Software without charge by offering media or download from OMRON's website. And if the User discovers defect of media which is attributable to OMRON and return it to OMRON within the above warranty period, OMRON will replace defective media without charge. If OMRON is unable to replace defective media or correct the Software, the liability of OMRON and the User's remedy shall be limited to the refund of the license fee paid to OMRON for the Software.

LIMITATION OF LIABILITY

- THE ABOVE WARRANTY SHALL CONSTITUTE THE USER'S SOLE AND EXCLUSIVE REMEDIES AGAINST OMRON AND THERE ARE NO OTHER WARRANTIES, EXPRESSED OR IMPLIED, INCLUDING BUT NOT LIMITED TO, WARRANTY OF MERCHANTABILITY OR FITNESS FOR PARTICULAR PURPOSE. IN NO EVENT, OMRON WILL BE LIABLE FOR ANY LOST PROFITS OR OTHER INDIRECT, INCIDENTAL, SPECIAL OR CONSEQUENTIAL DAMAGES ARISING OUT OF USE OF THE SOFTWARE.
- OMRON SHALL HAVE NO LIABILITY FOR DEFECT OF THE SOFTWARE BASED ON MODIFICATION OR ALTERNATION TO THE SOFTWARE BY THE USER OR ANY THIRD PARTY.
- OMRON SHALL HAVE NO LIABILITY FOR SOFTWARE DEVELOPED BY THE USER OR ANY THIRD PARTY BASED ON THE SOFTWARE OR ANY CONSEQUENCE THEREOF.

APPLICABLE CONDITIONS

USER SHALL NOT USE THE SOFTWARE FOR THE PURPOSE THAT IS NOT PROVIDED IN THE ATTACHED USER MANUAL.

CHANGE IN SPECIFICATION

The software specifications and accessories may be changed at any time based on improvements and other reasons.

ERRORS AND OMISSIONS

The information in this manual has been carefully checked and is believed to be accurate; however, no responsibility is assumed for clerical, typographical, or proofreading errors, or omissions.

Version Upgrade Information

Improvements from Version 1.9 to Version 1.91

New Operating System Support

Item	Ver. 1.9	Ver. 1.91
Operating system	Windows 2000, XP, and Vista supported	Windows 2000, XP, Vista, and Windows 7 supported

Improvements from Version 1.8 to Version 1.9

New Applicable Hardware

Item	Ver. 1.8	Ver. 1.9
Applicable Servo Drives	W-series Servo Drives W-series Servo Drives with Built-in MECHATROLINK-II Communications SMARTSTEP Junior Servo Drives with Built-in MECHATROLINK-II Communications G-series Servo Drives with Built-in MECHATROLINK-II Communications	W-series Servo Drives W-series Servo Drives with Built-in MECHATROLINK-II Communications SMARTSTEP Junior Servo Drives with Built-in MECHATROLINK-II Communications G-series Servo Drives with Built-in MECHATROLINK-II Communications G5-series Servo Drives with Built-in MECHATROLINK-II Communications

Improvements from Version 1.6 to Version 1.8

Support for New Models

Item	Ver. 1.6	Ver. 1.8
Position Control Units	CS1W-NCF71 CJ1W-NCF71	CS1W-NCF71 CS1W-NC471 CS1W-NC271 CJ1W-NCF71 CJ1W-NC471 CJ1W-NC271

Improvements from Version 1.5 to Version 1.6

New Applicable Hardware

Item	Ver. 1.5	Ver. 1.6
Applicable Servo Drives	W-series Servo Drives with Built-in MECHATROLINK-II Communications SMARTSTEP Junior Servo Drives with Built-in MECHATROLINK-II Communications	W-series Servo Drives W-series Servo Drives with Built-in MECHATROLINK-II Communications SMARTSTEP Junior Servo Drives with Built-in MECHATROLINK-II Communications G-series Servo Drives with Built-in MECHATROLINK-II Communications
PLCs	CS/CJ-series PLCs (excluding CJ2 CPU Units) CP-series PLCs NSJ-series Controllers FQM1-series Motion Controllers	CS/CJ-series PLCs (including CJ2 CPU Units) CP-series PLCs NSJ-series Controllers FQM1-series Motion Controllers

Improvements from Version 1.4 to Version 1.5

New Operating System Support

Item	Ver. 1.4	Ver. 1.5
Operating system	Windows 98, ME, NT 4.0, 2000, and XP supported	Windows 98, ME, NT 4.0, 2000, XP, and Vista supported

Improvements from Version 1.3 to Version 1.4

New Applicable Hardware

Item	Ver. 1.3	Ver. 1.4
Position Control Units	Functions in Position Control Units with unit version 1.3 or earlier are supported	Functions in Position Control Units with unit version 2.0 or earlier are supported. <ul style="list-style-type: none"> • Origin Search Operation Mode has been added. • Preset function for origin searches has been added.
Applicable Servo Drives	W-series Servo Drives W-series Servo Drives with Built-in MECHATROLINK-II Communications	W-series Servo Drives W-series Servo Drives with Built-in MECHATROLINK-II Communications and SMARTSTEP Junior Servo Drives with Built-in MECHATROLINK-II Communications

Improvements from Version 1.2 to Version 1.3

Setting Up an Absolute Encoder

Ver. 1.2	Ver. 1.3
An absolute encoder could not be set up.	An absolute encoder can be set up by communicating through the Position Control Unit.

New Applicable Hardware

Item	Ver. 1.2	Ver. 1.3
Position Control Units	CJ1W-NCF71	CJ1W-NCF71 and CS1W-NCF71
PLCs	CJ-series PLCs	CS/CJ-series PLCs, CP-series PLCs, NSJ-series NSJ Controllers, and FQM1 Flexible Motion Controllers (See note.)

Note Only FQM1 Flexible Motion Controllers with unit version 3.0 or later are supported.

Improvements from Version 1.1 to Version 1.2

Installing the CX-Motion-NCF from the CX-One FA Integrated Tool Package

Ver. 1.1	Ver. 1.2
The CX-Motion-NCF could be installed only independently.	The CX-Motion-NCF can be installed as one of the functions of the CX-One Integrated Tool Package.

CX-Motion-NCF Startup Method

Ver. 1.1	Ver. 1.2
The CX-Motion-NCF could be started only from the Windows Start Menu.	The CX-Motion-NCF can also be started by right-clicking the following Position Control Unit in the I/O Table Window opened from the CX-Programmer that was installed from the CX-One and selecting <i>Start Special Application</i> from the pop-up menu. <ul style="list-style-type: none"> • CJ1W-NC71 <p>Note When <i>Start with Settings Inherited</i> is selected, a new project will be created and a Position Control Unit will be automatically added.</p>

Improvements from Version 1.0 to Version 1.1

Supporting New Models of W-series Servo Drive

Item	Ver. 1.0	Ver. 1.1
Applicable Servo Drives	W-series Servo Drives	W-series Servo Drives <u>W-series Servo Drives with Built-in MECHATROLINK Communications</u>

Versions and Applicable Models

Versions of Support Software and Applicable Models

The models that are supported by the CX-Motion-NCF Position Control Unit Support Software are listed in the following table.

Version		Position Control Unit	PLC	Servo Drive
Software version	CX-One Version			
Ver. 1.0	Not supported	CJ1W-NCF71	CJ-series PLCs (except for CJ2 CPU Units)	W-series Servo Drives
Ver. 1.1	Not supported	CJ1W-NCF71	CJ-series PLCs (except for CJ2 CPU Units)	W-series Servo Drives W-series Servo Drives with Built-in MECHATROLINK-II Communications
Ver. 1.2	Ver. 1.□	CJ1W-NCF71	CJ-series PLCs (except for CJ2 CPU Units)	W-series Servo Drives W-series Servo Drives with Built-in MECHATROLINK-II Communications
Ver. 1.30	Ver. 1.□	CS1W-NCF71 CJ1W-NCF71	CS/CJ-series PLCs (except for CJ2 CPU Units) CP-series PLCs NSJ-series NSJ Controllers FQM1 Flexible Motion Controllers (See note.)	W-series Servo Drives W-series Servo Drives with Built-in MECHATROLINK-II Communications
Ver. 1.31	Ver. 2.□	CS1W-NCF71 CJ1W-NCF71	CS/CJ-series PLCs (except for CJ2 CPU Units) CP-series PLCs NSJ-series NSJ Controllers FQM1 Flexible Motion Controllers (See note.)	W-series Servo Drives W-series Servo Drives with Built-in MECHATROLINK-II Communications SMARTSTEP Junior Drives with Built-in MECHATROLINK-II Communications
Ver. 1.4	Ver. 2.□	CS1W-NCF71 CJ1W-NCF71	CS/CJ-series PLCs (except for CJ2 CPU Units) CP-series PLCs NSJ-series NSJ Controllers FQM1 Flexible Motion Controllers (See note.)	W-series Servo Drives W-series Servo Drives with Built-in MECHATROLINK-II Communications SMARTSTEP Junior Servo Drives with Built-in MECHATROLINK-II Communications

Version		Position Control Unit	PLC	Servo Drive
Software version	CX-One Version			
Ver. 1.50	Ver. 2.□	CS1W-NCF71 CJ1W-NCF71	CS/CJ-series PLCs (except for CJ2 CPU Units) CP-series PLCs NSJ-series NSJ Controllers FQM1 Flexible Motion Controllers (See note.)	W-series Servo Drives W-series Servo Drives with Built-in MECHATROLINK-II Communications SMARTSTEP Junior Servo Drives with Built-in MECHATROLINK-II Communications
Ver. 1.51	Ver. 2.□	CS1W-NCF71 CJ1W-NCF71	CS/CJ-series PLCs (except for CJ2 CPU Units) CP-series PLCs NSJ-series NSJ Controllers FQM1 Flexible Motion Controllers (See note.)	W-series Servo Drives W-series Servo Drives with Built-in MECHATROLINK-II Communications SMARTSTEP Junior Servo Drives with Built-in MECHATROLINK-II Communications G-series Servo Drives with Built-in MECHATROLINK-II Communications
Ver. 1.6	Ver. 3.□	CS1W-NCF71 CJ1W-NCF71	CS/CJ-series PLCs (except for CJ2 CPU Units) CP-series PLCs NSJ-series NSJ Controllers FQM1 Flexible Motion Controllers (See note.)	W-series Servo Drives W-series Servo Drives with Built-in MECHATROLINK-II Communications SMARTSTEP Junior Servo Drives with Built-in MECHATROLINK-II Communications G-series Servo Drives with Built-in MECHATROLINK-II Communications
Ver. 1.7	Ver. 2.□	CS1W-NCF71 CS1W-NC471 CS1W-NC271 CJ1W-NCF71 CJ1W-NC471 CJ1W-NC271	CS/CJ-series PLCs (except for CJ2 CPU Units) CP-series PLCs NSJ-series NSJ Controllers FQM1 Flexible Motion Controllers (See note.)	W-series Servo Drives W-series Servo Drives with Built-in MECHATROLINK-II Communications SMARTSTEP Junior Servo Drives with Built-in MECHATROLINK-II Communications G-series Servo Drives with Built-in MECHATROLINK-II Communications
Ver. 1.71	Ver. 2.□	CS1W-NC271 CS1W-NC471 CS1W-NCF71 CJ1W-NC271 CJ1W-NC471 CJ1W-NCF71	CS/CJ-series PLCs except for CJ2 CPU Units CP-series PLCs NSJ-series NSJ Controllers FQM1 Flexible Motion Controllers (See note.)	W-series Servo Drives W-series Servo Drives with Built-in MECHATROLINK-II Communications SMARTSTEP Junior Servo Drives with Built-in MECHATROLINK-II Communications G-series Servo Drives with Built-in MECHATROLINK-II Communications G5-series Servo Drives with Built-in MECHATROLINK-II Communications

Version		Position Control Unit	PLC	Servo Drive
Software version	CX-One Version			
Ver. 1.8	Ver. 3.□	CS1W-NCF71 CS1W-NC471 CS1W-NC271 CJ1W-NCF71 CJ1W-NC471 CJ1W-NC271	CS/CJ-series PLCs (except for CJ2 CPU Units) CP-series PLCs NSJ-series NSJ Controllers FQM1 Flexible Motion Controllers (See note.)	W-series Servo Drives W-series Servo Drives with Built-in MECHATROLINK-II Communications SMARTSTEP Junior Servo Drives with Built-in MECHATROLINK-II Communications G-series Servo Drives with Built-in MECHATROLINK-II Communications
Ver. 1.9 Ver. 1.91	Ver. 4.□	CS1W-NC271 CS1W-NC471 CS1W-NCF71 CJ1W-NC271 CJ1W-NC471 CJ1W-NCF71	CS/CJ-series PLCs except for CJ2 CPU Units CP-series PLCs NSJ-series NSJ Controllers FQM1 Flexible Motion Controllers (See note.)	W-series Servo Drives W-series Servo Drives with Built-in MECHATROLINK-II Communications SMARTSTEP Junior Servo Drives with Built-in MECHATROLINK-II Communications G-series Servo Drives with Built-in MECHATROLINK-II Communications G5-series Servo Drives with Built-in MECHATROLINK-II Communications

Note Only FQM1 Flexible Motion Controllers with unit version 3.0 or later are supported.

Unit Versions

A “unit version” has been introduced to manage Position Control Units according to differences in functionality accompanying Unit upgrades.

Notation of Unit Versions on Products

The unit version is given to the right of the lot number on the nameplate of the products for which unit versions are being managed, as shown below.

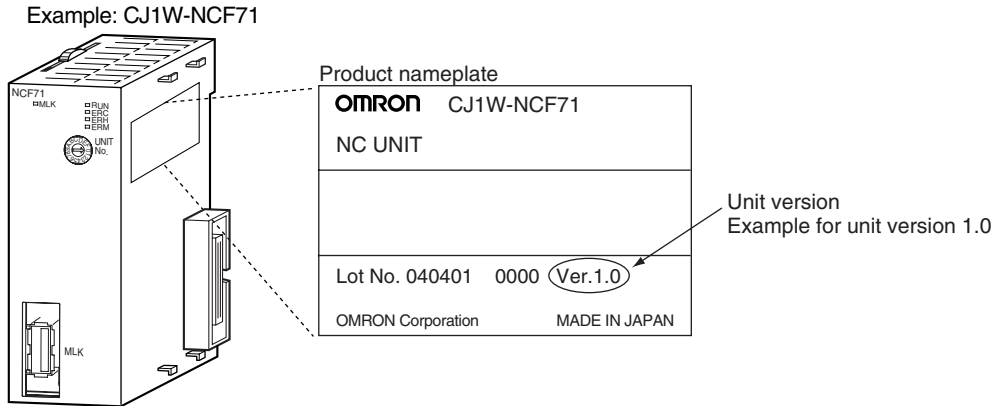

The unit version of Position Control Units starts with unit version 1.0 for the CJ1W-NCF71 and unit version 1.3 for the CS1W-NCF71.

Confirming Unit Versions with Support Software

CX-Programmer version 4.0 or higher can be used to confirm the unit version using the **Unit Manufacturing Information**.

1,2,3...

1. In the *IO Table* Window, right-click the Position Control Unit and select **Unit Manufacturing information**.
2. The following *Unit Manufacturing information* Dialog Box will be displayed. Use the following display to confirm the unit version of the Position Control Unit connected online.

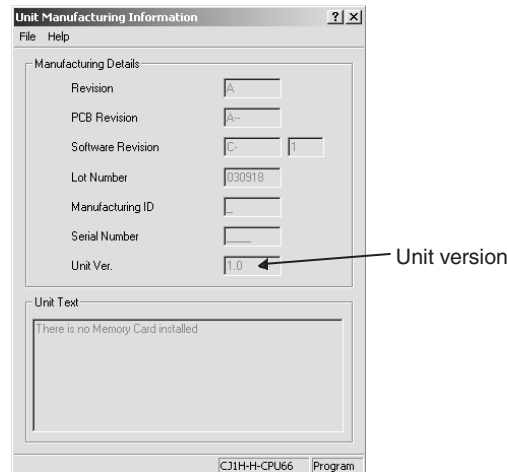

The unit version is displayed as 1.0 in the *Unit Version Number* field of the above example.

Using Unit Version Label

A unit version label is provided with the Position Control Unit. This label can be attached to the front of the Position Control Unit to differentiate between Position Control Units with different unit versions.

Functions Supported According to Position Control Unit Versions

Model	CJ1W-NCF71/CS1W-NCF71				
	Unit Ver. 1.0	Unit Ver. 1.1	Unit Ver. 1.2	Unit Ver. 1.3	Unit Ver. 2.0
Linear interpolation	Not supported.	Supported.	Supported.	Supported.	Supported.
Setting up an absolute encoder	Not supported.	Not supported.	Supported.	Supported.	Supported.
Resetting the error counter	Not supported.	Not supported.	Not supported.	Supported.	Supported.
Establishing connections when there are unconnected axes or alarms that cannot be reset	Not supported.	Not supported.	Not supported.	Supported.	Supported.
Transferring Servo parameters when there is an axis error	Not supported.	Not supported.	Not supported.	Supported.	Supported.
Locking the Servo when a software limit has been detected when using a motor with an absolute encoder	Not supported.	Not supported.	Not supported.	Supported.	Supported.
Detecting drive circuit OFF error only when the Servo is locked	Not supported.	Not supported.	Not supported.	Supported.	Supported.
Allocating H512 and latter addresses in the Holding Area in function blocks.	Not supported.	Not supported.	Not supported.	Supported.	Supported.
SMARTSTEP Junior Servo Drives (R7D-ZN□-ML2)	Not supported.	Not supported.	Not supported.	Not supported.	Supported.
Re-establishing connections	Not supported.	Not supported.	Not supported.	Not supported.	Supported.
Improving the connection limits when Servo Drive alarms occur (Possible to establish connection when A.C90 occurs.)	Not supported.	Not supported.	Not supported.	Not supported.	Supported.
Origin Search Operation Mode	Not supported.	Not supported.	Not supported.	Not supported.	Supported.
Preset function for origin searches	Not supported.	Not supported.	Not supported.	Not supported.	Supported.

Support Software and Unit Version Support

Function support that depends on the combination of the software version of the CX-Motion-NCF Support Software and the unit version of the Position Control Unit is as shown in the following table.

Support Software function	Support Software version	Unit Ver. 1.0	Unit Ver. 1.1	Unit Ver. 1.2	Unit Ver. 1.3	Unit Ver. 2.0
W-series Servo Drives with MECHATROLINK communications	1.1 or higher	Supported.	Supported.	Supported.	Supported.	Supported.
Bundling in CX-One	1.2 or higher	Supported.	Supported.	Supported.	Supported.	Supported.
Setting up an absolute encoder	1.3 or higher	Not supported.	Not supported.	Supported.	Supported.	Supported.
Transferring Servo parameters when there is an axis error	1.3 or higher	Not supported.	Not supported.	Not supported.	Supported.	Supported.
Origin Search Operation Mode added in Position Control Units with unit version 2.0	1.4 or higher	Not supported.	Not supported.	Not supported.	Not supported.	Supported.
Preset function for origin searches added in Position Control Units with unit version 2.0	1.4 or higher	Not supported.	Not supported.	Not supported.	Not supported.	Supported.
SMARTSTEP Junior with Built-in MECHATROLINK-II Communications	1.4 or higher	Not supported.	Not supported.	Not supported.	Not supported.	Supported.

Note The function to re-establishing connections added in the unit version 2.0 is not supported by the CX-Motion-NCF. The Position Control Unit communicates with all of axes registered in a scan list when the CX-Motion-NCF starts communications between a Position Control Unit and a Servo Drive. The connected axis designation will be invalid.

PRECAUTIONS

This section provides general precautions for using the CX-Motion-NCF software package.

The information contained in this section is important for the safe and reliable application of the CX-Motion-NCF. You must read this section and understand the information contained before attempting to set up or operate the CX-Motion-NCF.

1	Intended Audience	xx
2	General Precautions	xx
3	Safety Precautions	xx
4	Operating Environment Precautions	xxi
5	Application Precautions	xxi

1 Intended Audience

This manual is intended for the following personnel, who must also have knowledge of electrical systems (an electrical engineer or the equivalent).

- Personnel in charge of installing FA systems.
- Personnel in charge of designing FA systems.
- Personnel in charge of managing FA systems and facilities.

2 General Precautions

The user must operate the product according to the performance specifications described in the operation manuals.

Before using the product under conditions which are not described in the manual or applying the product to nuclear control systems, railroad systems, aviation systems, vehicles, combustion systems, medical equipment, amusement machines, safety equipment, and other systems, machines, and equipment that may have a serious influence on lives and property if used improperly, consult your OMRON representative.

Make sure that the ratings and performance characteristics of the product are sufficient for the systems, machines, and equipment, and be sure to provide the systems, machines, and equipment with double safety mechanisms.

This manual provides information for programming and operating the Unit. Be sure to read this manual before attempting to use the Unit and keep this manual close at hand for reference during operation.

 **WARNING** It is extremely important that the CX-Motion-NCF and related devices be used for the specified purpose and under the specified conditions, especially in applications that can directly or indirectly affect human life. You must consult with your OMRON representative before applying Position Control Units and related devices to the above-mentioned applications.

3 Safety Precautions

 **WARNING** Do not attempt to take any Unit apart while the power is being supplied. Doing so may result in electric shock.

 **WARNING** Never touch any of the terminals while power is being supplied. Doing so may result in serious electric shock.

 **Caution** Always back up parameters to the flash memory after it has been transferred to the Position Control Unit. If transferred data is not backed up in flash memory, the previous settings may be used the next time the power is turned ON, resulting in a malfunction.

 **Caution** Confirm safety at the destination node before transferring parameters to another node. Doing either of these without confirming safety may result in injury.

 **Caution** Check that the axis number is correct before operating an axis from the CX-Motion-NCF.

4 Operating Environment Precautions

 **Caution** Do not operate the control system in the following locations:

- Locations subject to direct sunlight.
- Locations subject to temperatures or humidity outside the range specified in the specifications.
- Locations subject to condensation as the result of severe changes in temperature.
- Locations subject to corrosive or flammable gases.
- Locations subject to dust (especially iron dust) or salts.
- Locations subject to exposure to water, oil, or chemicals.
- Locations subject to shock or vibration.

 **Caution** Take appropriate and sufficient countermeasures when installing systems in the following locations:

- Locations subject to static electricity or other forms of noise.
- Locations subject to strong electromagnetic fields.
- Locations subject to possible exposure to radioactivity.
- Locations close to power supplies.

5 Application Precautions

Observe the following precautions when using the CX-Motion-NCF.

- Confirm that the correct unit number is specified for the destination node before transferring parameters to the Position Control Unit.
- Confirm that set parameters operate properly before using them in actual applications.
- Always turn ON the power to the Unit again or restart the CPU Bus Unit after transferring the following parameter settings and writing them to flash memory. Otherwise, the changed parameter settings will not be enabled.
 - Common parameters
 - Axis parameters
- Do not turn OFF the power to the Unit while writing to flash memory. Doing so may result in damage to the flash memory.
- Confirm that no adverse effect will occur in the system before attempting any of the following. Not doing so may result in an unexpected operation.
 - Changing the operating mode of the PLC (including changing the Start-up Mode).
 - Force-setting/force-resetting any bit in memory.
 - Changing the present value of any word or any set value in memory.
- Do not turn OFF the power to the personal computer while installing or uninstalling the CX-Motion-NCF. Doing so may result in corrupted data in the personal computer.

SECTION 1

CX-Motion-NCF Overview

This section provides an overview of the CX-Motion-NCF, and describes the functions and system configuration required to operate the CX-Motion-NCF.

1-1	What is CX-Motion-NCF?	2
1-2	System Configuration	4
1-3	Function List	4
1-4	Operation Procedure	6

1-1 What is CX-Motion-NCF?

What is CX-Motion-NCF?

The CX-Motion-NCF is a software package that helps to set, transfer, save, and print various data used for the CS1W-NC271/471/F71/CJ1W-NC271/471/F71 Position Control Units (also referred to as NC Units) and to monitor the operation status of the Position Control Unit.

The CX-Motion-NCF runs on any OS that is supported by the CX-One.

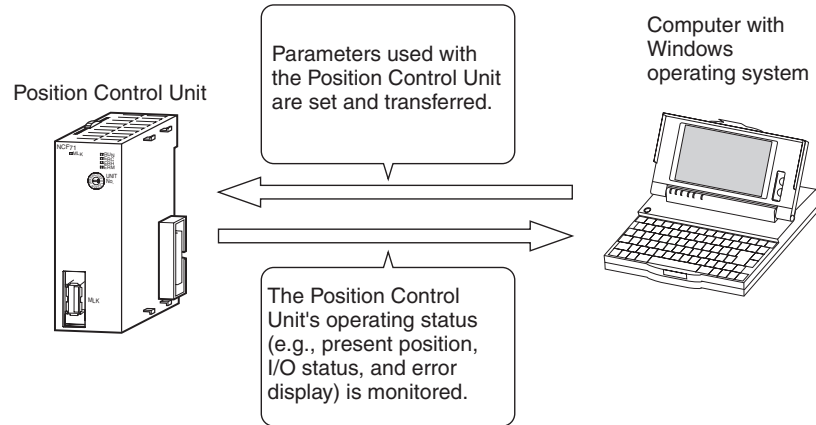

Applicable Position Control Units

The CX-Motion-NCF supports the following Position Control Units.

Applicable Position Control Units	Applicable Controllers
CS1W-NC271 CS1W-NC471 CS1W-NCF71	CS-series PLCs
CJ1W-NC271 CJ1W-NC471 CJ1W-NCF71	CJ-series PLCs, CP-series PLCs, NSJ-series NSJ Controllers, and FQM1 Flexible Motion Controllers (See note.)

Note Only FQM1 Flexible Motion Controllers with unit version 3.0 or later are supported.

Features

Data Management and Editing in Project Units

The CX-Motion-NCF manages data for several Position Control Units as one project. Position Control Units are displayed under a PLC and several Servo Drives (CS1W-NCF71/CJ1W-NCF71: 16 axes max., CS1W-NC471/CJ1W-NC471: 16 axes max., CS1W-NC271/CJ1W-NC271: 16 axes max.) are displayed under a Position Control Unit, both in tree format.

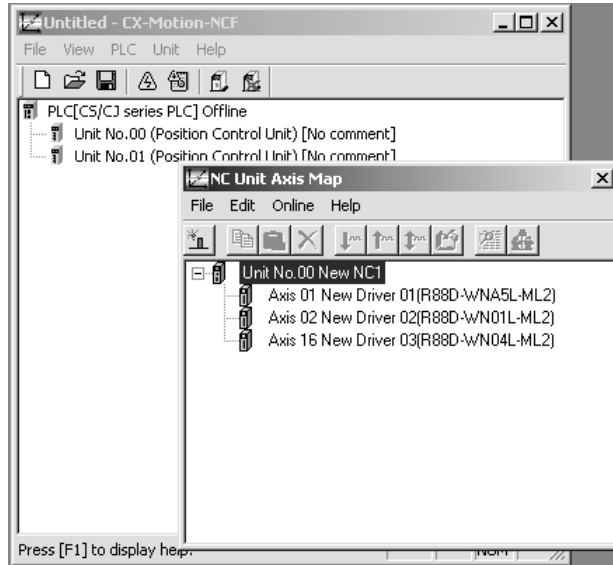

Communications with Position Control Units via Networks

The CX-Motion-NCF communicates with Position Control Units using CX-Server.

Host Link (SYSMAC WAY) or peripheral bus (Toolbus) can be used to perform online operations (transferring, comparing, and monitoring parameter data) with the Position Control Unit on the PLC.

Editing Servo Parameters

Parameters of Servo Drives connected to a Position Control Unit can be edited using the CX-Motion-NCF.

Displaying Error Information

Information on the error that is currently occurring on a Position Control Unit or the error log can be displayed.

Applicable Computers

Refer to the *CX-One Ver. 3.0 Setup Manual* (Cat. No. W463) for the computer system requirements for the CX-Motion-NCF.

CX-Motion-NCF Data

The CX-Motion-NCF is used to create project files with the configuration shown below. The file extension for project files is .mnf.

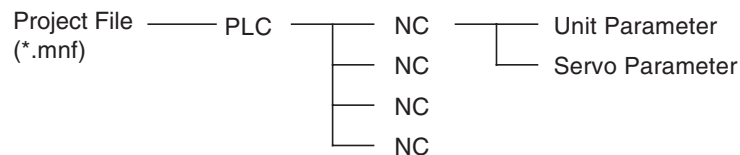

Software Structure

The CX-Motion-NCF exchanges data (online communications) with Position Control Units via CX-Server. In order to execute functions online, CX-Server must be installed on the same computer that has the CX-Motion-NCF installed.

1-2 System Configuration

The system configuration for Position Control Units is shown below.
The example shown here is for the CJ1W-NCF71.

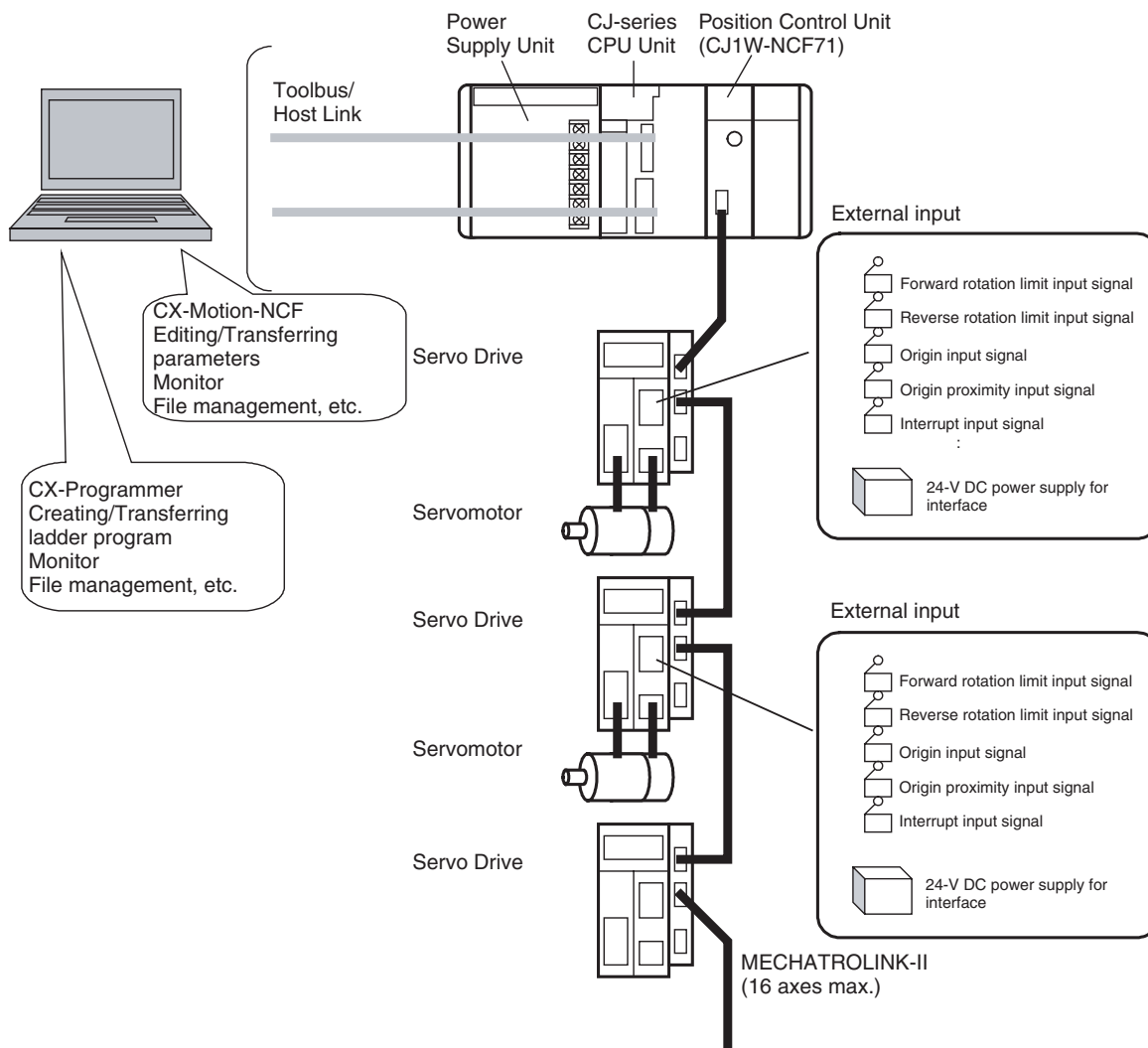

1-3 Function List

Group	Function	Details	Reference
Editing projects	Create project	Used to create project files (*.mnf)	4-1 Creating a New Project
	Create Position Control Unit	Used to add Position Control Unit data to a project.	4-2 Adding and Deleting Position Control Units
	Create Servo Drive	Used to add Servo Drive data to a project.	4-3 Adding and Deleting Servo Drives
Editing data	Edit Unit Parameters	Used to edit Unit Parameters.	5-1 Editing Unit Parameters
	Edit Servo Parameters	Used to edit Servo Parameters.	5-2 Editing Servo Parameters
Saving and reading project files	Save project	Used to save data as a project file (*.mnf).	6-1 Saving Project
	Read project	Used to read a project file (*.mnf).	6-2 Reading Project

Group	Function	Details	Reference
Importing and exporting data	Import	Used to import Unit/Servo Parameters.	<i>6-3 Import</i>
	Export	Used to export Unit/Servo Parameters.	<i>6-4 Export</i>
Printing	Print	Used to print the data displayed on the screen.	<i>6-5 Print</i>
Online	Initial setting	Used to setup CPU Unit or Position Control Unit.	<i>7-1 Initial Setting for Connecting Online</i>
	Communications setting	Used to make communications settings.	<i>7-2 Setting/Changing Communications Specific</i>
	Download Upload Compare	Used to download, compare, or upload Unit or Servo Parameters.	<i>7-3 Downloading Data</i> <i>7-4 Uploading Data</i> <i>7-5 Comparing Data</i>
	Write to flash memory	Used to save the downloaded Unit Parameters.	<i>7-6 Writing to Flash Memory</i>
	Monitor	Used to display the Unit's status, axis present position, axis status, and error information.	<i>8-1 Unit Monitor</i> <i>8-2 Axis Monitor</i>
	Device information	Used to read the Position Control Unit model, Position Control Unit internal software version, and other Unit-related information.	---
	Absolute encoder setup	Used to set up an absolute encoder.	<i>10-1 Absolute Encoder Setup</i>
JOG	JOG	Used to execute JOG operation.	<i>9-1 Test Run</i>
Error	Error log	Used to display the error log.	<i>11-1 Error Log</i>

1-4 Operation Procedure

The outline of the procedures required to install the CX-Motion-NCF and CX-Server, create various data, transfer it to Position Control Units, and use in actual operations is shown below.

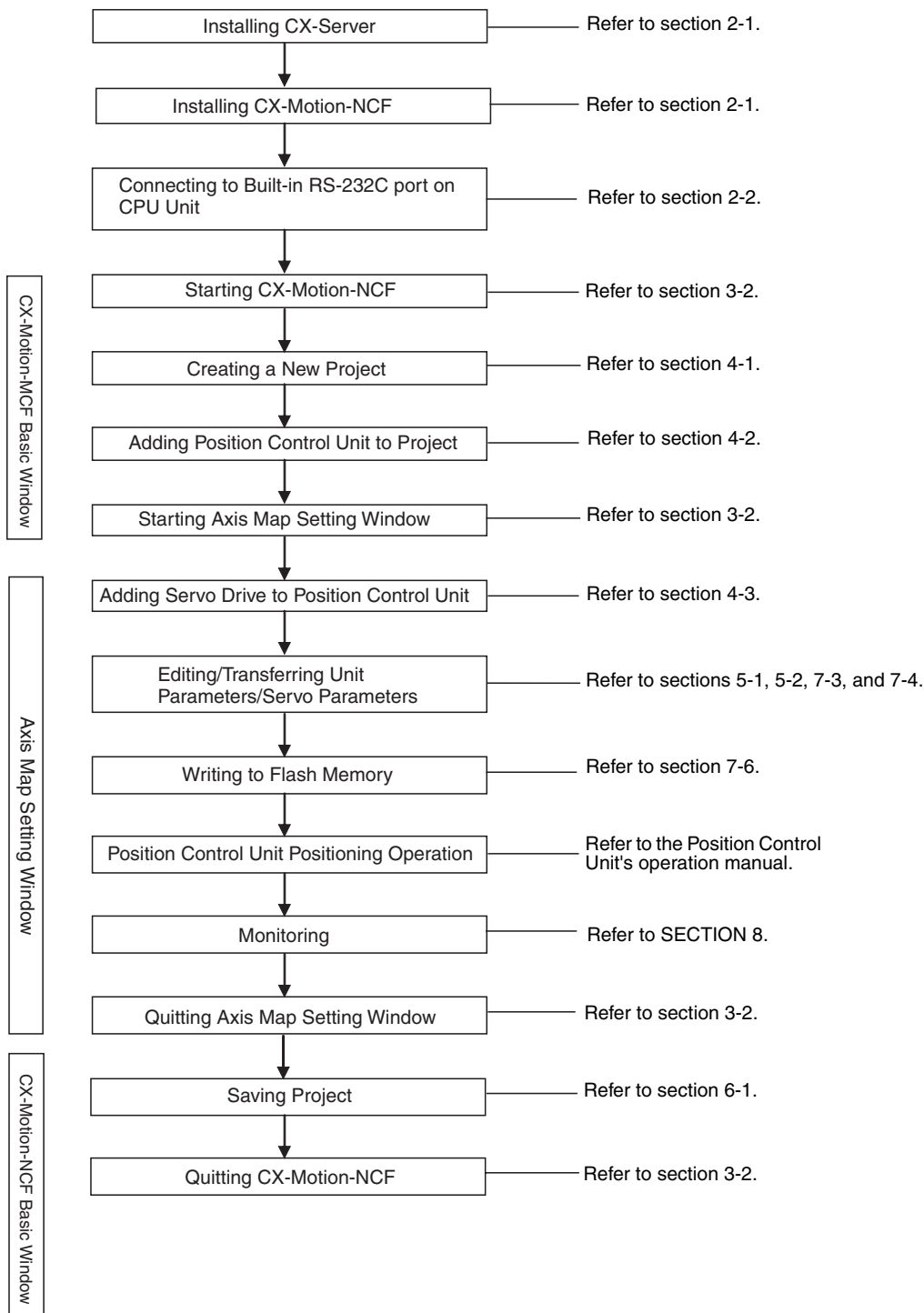

SECTION 2

Setup

This section provides information on installing the CX-Motion-NCF and CX-Server, and connecting to the PLC.

2-1	Installing and Uninstalling the Software	8
2-1-1	Software That Must Be Installed	8
2-2	Connecting to PLC	8
2-2-1	Connecting to CS/CJ-series PLCs	8
2-2-2	Connecting to CP-series PLCs	10
2-2-3	Connecting to CJ2 PLCs	11

2-1 Installing and Uninstalling the Software

2-1-1 Software That Must Be Installed

The following software must be installed on the same computer to use the CX-Motion-NCF.

- 1,2,3... 1. CX-Motion-NCF
2. CX-Server (the communications driver)

Installing of CX-Motion-NCF

Refer to the *CX-One Setup Manual* (Cat. No. W463) (supplied with the CX-One FA Integrated Tool Package) for information on how to install or uninstall the CX-Motion-NCF from the CX-One FA Integrated Tool Package.

Cat. No.	Model	Manual name	Contents
W463	CXONE-AL□□D-V4	CX-One Setup Manual	An overview of the CX-One FA Integrated Tool Package and the CX-One installation procedure

2-2 Connecting to PLC

To transfer the project data that was created using CX-Motion-NCF to the Position Control Unit. The personal computer and PLC (CPU Unit) must be physically connected with a cable and also connected online.

2-2-1 Connecting to CS/CJ-series PLCs

Connection Format

Using either the Host Link (SYSMAC WAY) or Toolbus, connect the personal computer to the peripheral port or RS-232C port on the PLC.

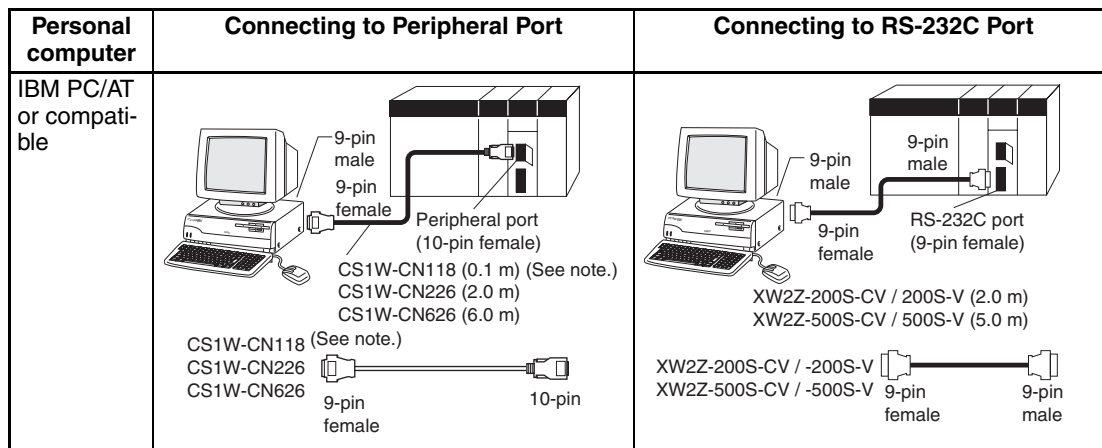

Note The cable model CS1W-CN118 is used as a relay cable to connect the personal computer to the CPU Unit's peripheral port using the RS-232C cable (model XW2Z-□□□□-□□) as shown below.

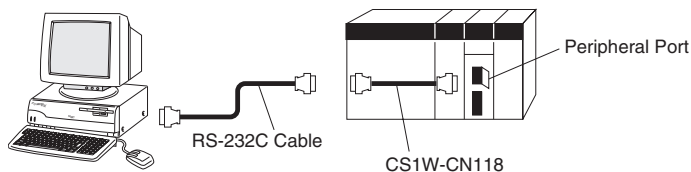

Note Two network types (serial communications mode), SYSMAC WAY and Toolbus, are supported when connecting CX-Motion-NCF to the PLC. The characteristics of the network types are as shown below.

Network type	Characteristics
Toolbus	Faster communications. If possible, use this network type. <ul style="list-style-type: none"> • For CS/CJ Series, the baud rate on the peripherals can be detected automatically, and be connected. • Only 1 on 1 connection possible. • For CX-Motion-NCF, it can also be connected to a modem.
SYSMAC WAY (Host Link)	Used for communications with general host computers. <ul style="list-style-type: none"> • Slower than Toolbus. • Not only 1 on 1 connection, but also 1-many connection possible. • Connecting to a modem and optical adaptor possible.

Connection Method

Use one of the following method to connect the personal computer (CX-Motion-NCF) and PLC (CPU Unit). It is also possible to connect the personal computer to the port on the CS/CJ-series Serial Communications Unit. In that case, the only network type that can be used is Host Link.

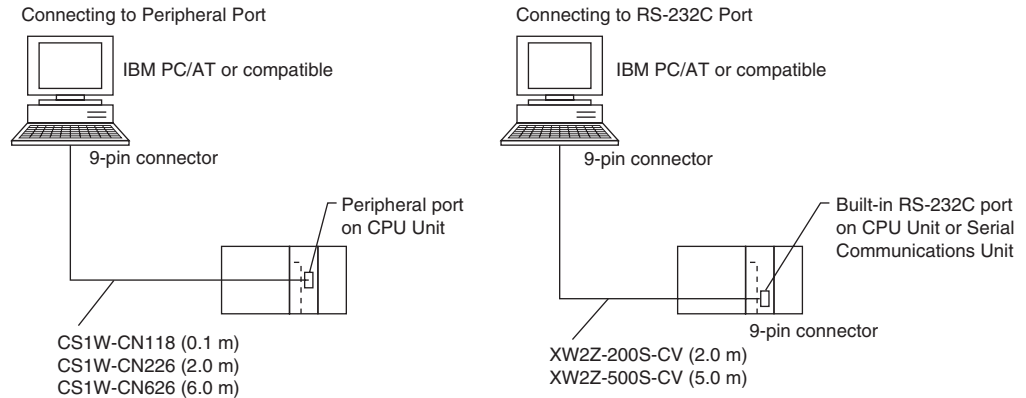

Connection Cables

Unit	Port on Unit	Computer	Port on computer	Network type (serial communications mode)	Model number	Length	Remarks
CPU Unit	Built-in peripheral port	IBM PC/AT compatible	D-Sub, 9-pin, male	SYSMAC WAY	CS1W-CN226	2 m	---
					CS1W-CN626	6 m	
	Built-in RS-232C port (D-Sub, 9-pin, female)	IBM PC/AT compatible	D-Sub, 9-pin, male	SYSMAC WAY	XW2Z-200S-CV	2 m	Uses anti-static connector
						XW2Z-500S-CV	
Serial Communications Unit	RS-232C port (D-Sub, 9-pin, female)	IBM PC/AT compatible	D-Sub, 9-pin, male	SYSMAC WAY	XW2Z-200S-CV	2 m	Uses anti-static connector
						XW2Z-500S-CV	

Note When connecting the connectors of the above cables to the PLC's RS-232C port, discharge any static build-up (e.g., by touching a grounded metal object) before touching the connectors. Although XW2Z-□□□S-CV Cables use the anti-static XM2S-0911-E Connector Hood (thus reducing the possibility of static build-up), be sure to discharge any static as a safety precaution.

2-2-2 Connecting to CP-series PLCs

Connecting to USB Port on CPU Unit with Commercially Available US Cable

Unit	Port on Unit	Computer	Port on computer	Serial communications mode (network type)	Model number	Length	Remarks
CPU Unit	USB port (B connector)	IBM PC/AT compatible	USB port (A connector)	USB	Commercially available USB 1.1 or 2.0 cable	5 m max.	---

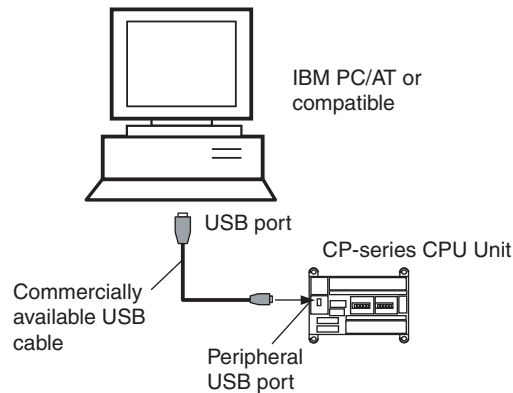

Connecting to RS-232C Port on Serial Communications Board with RS-232C Cable

Unit	Port on Unit	Computer	Port on computer	Serial communications mode (network type)	Model number	Length	Remarks
CP1W-CIF01 Serial Communications Board	RS-232C port, D-sub 9-pin female	IBM PC/AT compatible	D-Sub, 9-pin, male	Toolbus (Peripheral) or SYSMAC WAY (Host Link)	XW2Z-200S-CV/500S-CV	2 m/5 m	Uses anti-static connector
				SYSMAC WAY (Host Link)	XW2Z-200S-V/500S-V	2 m/5 m	---

2-2-3 Connecting to CJ2 PLCs

USB or RS-232C Connection

Unit	Port on Unit	Computer	Port on computer	Serial communications mode (network type)	Model number	Length	Remarks
CPU Unit	USB port (B connector)	IBM PC/AT compatible	USB port (A connector)	USB	Commercially available USB 1.1 or 2.0 cable	5 m max.	---
	Built-in RS-232C port, D-sub 9-pin female	IBM PC/AT compatible	D-sub 9-pin, male	Toolbus (See note.)	XW2Z-200S-CV/500S-CV	2 m/5 m	Uses anti-static connector

Note A Host Link (SYSMAC WAY) connection to an RS-232C port on the CPU Unit or a Serial Communications Unit is not possible for CJ2 PLCs.

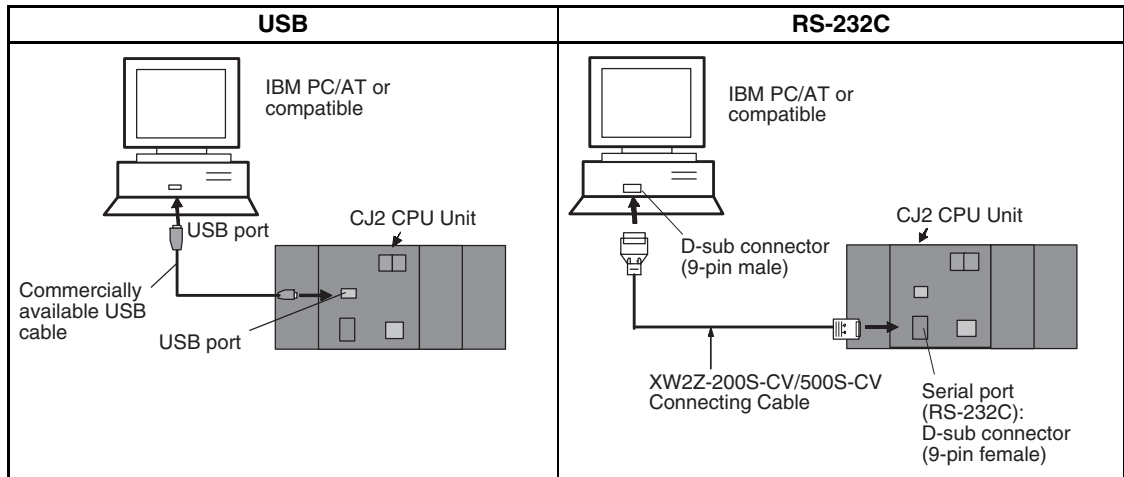

Ethernet Connection

Port on Unit	Port on computer	Serial communications mode (network type)	Model number	Length	Remarks
Built-in EtherNet/IP port	Ethernet port	100Base-TX/10Base-T (Recommended: 100Base-TX)	Commercially available twisted-pair cable based on EtherNet/IP standard	100 m (between hub and node)	---
			Commercially available switching hub	---	

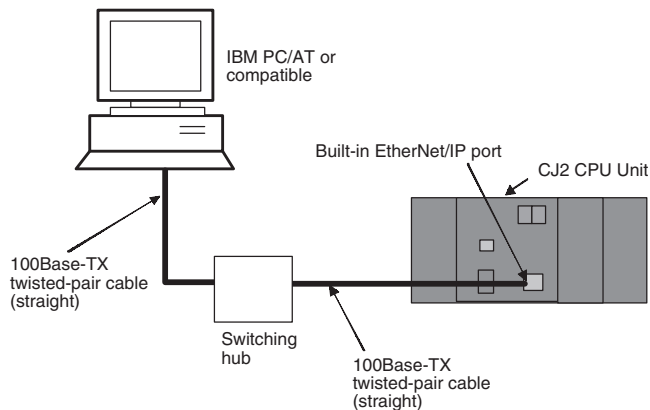

SECTION 3

Basic Operation

This section describes each of the screens and basic operations.

3-1	Screen Name	14
3-2	Basic Operation	17
3-2-1	CX-Motion-NCF Basic Operation	17
3-2-2	Axis Map Setting Window Basic Operation	21
3-3	Operations Listed by Purpose	24

3-1 Screen Name

The window names for the CX-Motion-NCF are shown here.

Basic Window

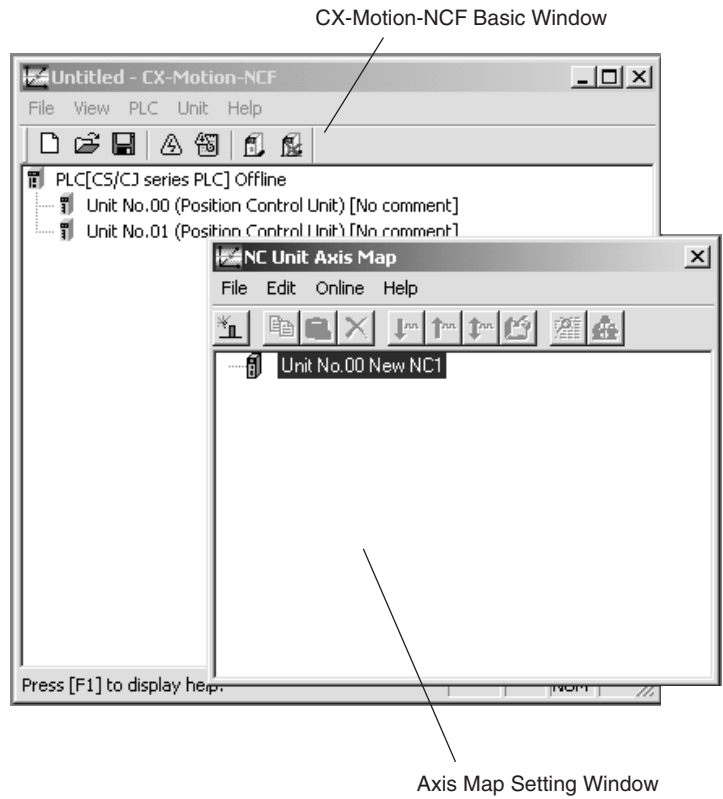

Edit Parameter Windows

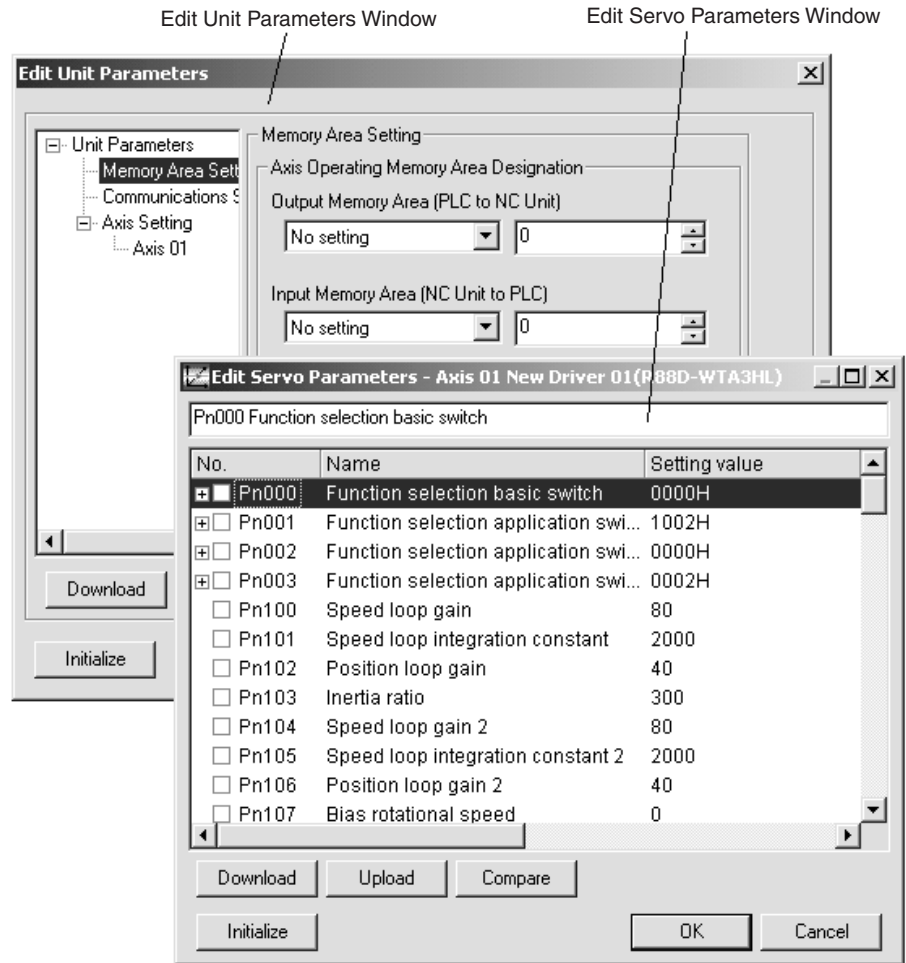

Monitor Windows

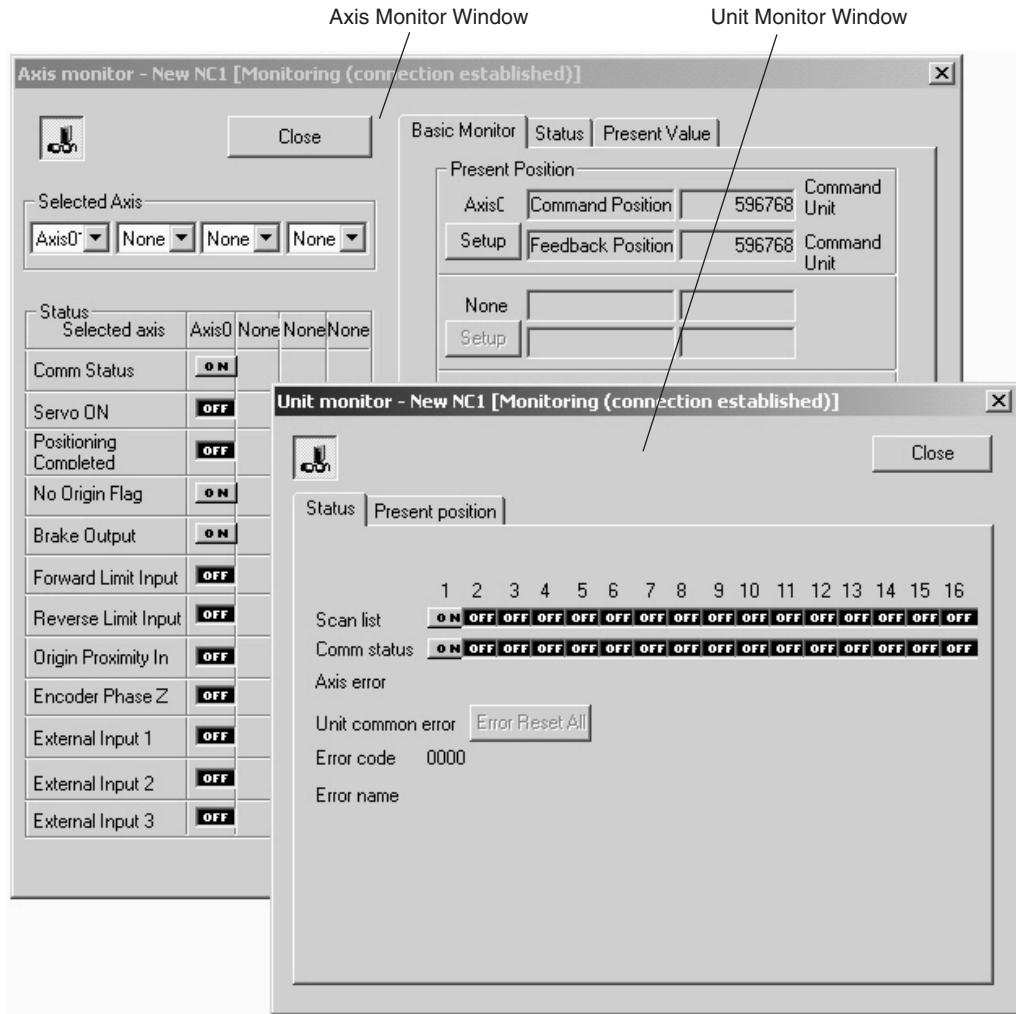

3-2 Basic Operation

3-2-1 CX-Motion-NCF Basic Operation

The basic operations of the CX-Motion-NCF are explained here.

Starting CX-Motion-NCF

Starting CX-Motion-NCF Using **Start Special Application - Start with Settings Inherited** from the I/O Table Window Opened from the CX-Programmer That Was Installed from the CX-One

- 1,2,3... 1. Right-click a Position Control Unit in the I/O Table Window and select **Start Special Application - Start with Settings Inherited** from the pop-up menu.

Example: Right-click the CJ1W-NCF71 Position Control Unit.

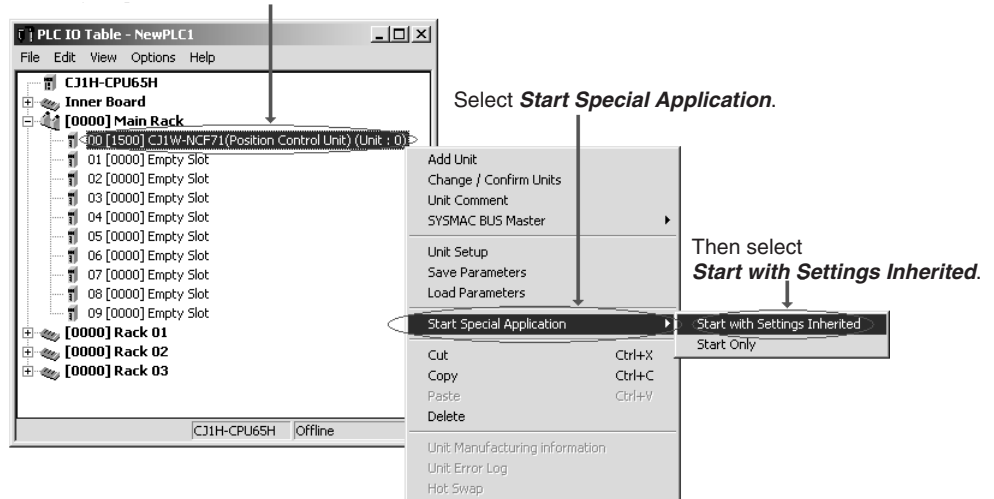

2. The CX-Motion-NCF will be started, a new project will be created, and a Position Control Unit will be added automatically. The Position Control Unit model will be inherited as shown below

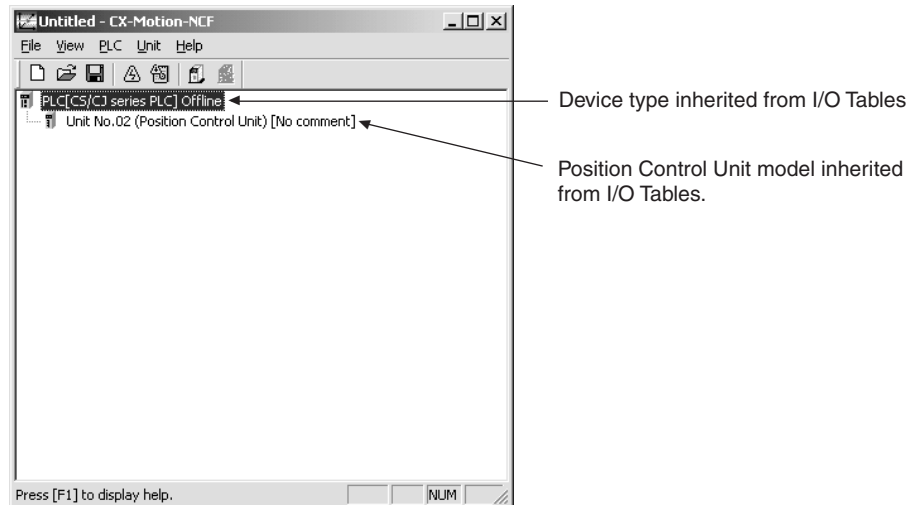

Starting CX-Motion-NCF Using *Start Special Application - Start Only* from the I/O Table Window Opened from the CX-Programmer That Was Installed from the CX-One

Right-click a Position Control Unit in the I/O Table Window and select **Start Special Application - Start Only** from the pop-up menu. The following window will be displayed with a new project.



Starting CX-Motion-NCF from Windows Start Menu

Select **Start - Programs - OMRON - CX-One - CX-Motion-NCF - CX-Motion-NCF**. The same window as when selecting **Start Only** will be displayed with a new project.

Quitting CX-Motion-NCF

1,2,3...

1. Select **File - Exit** or click the Close Button at the top right corner of the window. After editing a project, if the project has not been saved, the following dialog box will be displayed.

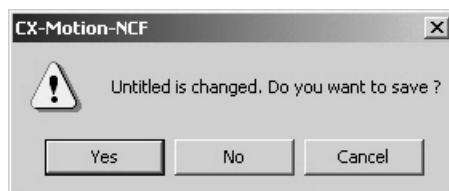

2. Click the **Yes** Button to save the changes made. Click the **No** Button if it is not necessary to save the changes. Click the **Cancel** Button to return to the Basic Window without quitting the CX-Motion-NCF.

CX-Motion-NCF Basic Window

The CX-Motion-NCF Basic Window is shown below.



Main Menus

Main Menu	Contents	Keyboard shortcut
File	Used to create or save projects.	Alt+F
View	Used to display or hide Toolbar or Status Bar.	Alt+V
PLC	Used to connect to PLC.	Alt+P
Unit	Used to add or delete Position Control Unit, or to open Axis Map Setting Window.	Alt+U
Help	Used to display help and version information. Also used to register online.	Alt+H

Main Menu Items

The names and functions for all of the menus are given in the following table. When an item is selected, the dialog box for that function is displayed. follow the instructions in the dialog box.

Main menu	Item	Contents	Keyboard shortcut
File	New	Creates a new project file.	Ctrl+N
	Open	Opens an existing project file.	Ctrl+O
	Save	Saves the active project (overwrites the previous data).	Ctrl+S
	Save As	Saves the active project with a new name.	---
	Exit	Quits the CX-Motion-NCF.	---
View	Toolbar	Displays/hides toolbar.	---
	Status Bar	Displays/hides status bar.	---
PLC	Online	Connects to PLC.	---
	Communication Settings	Sets communications for online connection.	---

Main menu	Item	Contents	Keyboard shortcut
Unit	Edit Parameters	Opens Axis Map Setting Window.	---
	Change Axis Type	Changes the model of the Position Control Unit (i.e., the axis type that is connected).	---
	Change Unit No.	Changes Unit No. of Position Control Unit.	---
	Edit Comment	Edits comment.	---
	Add	Adds Position Control Unit to a project.	---
	Delete	Deletes Position Control Unit from a project.	---
Help	Help Index	Displays the table of contents for help.	F1
	Online Registration	Connects to the OMRON CX-One Website for online user registration.	---
	About CX-Motion NCF..	Displays the version information for the CX-Motion-NCF.	---

Toolbar

Functions can be executed directly by clicking the appropriate icon on the toolbar. The functions that can be executed from the toolbar are given below.

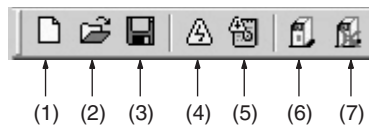

Number	Function
(1)	Creates a new project.
(2)	Opens an existing project.
(3)	Saves the active project.
(4)	Connects online to PLC.
(5)	Displays communications settings window to connect to PLC.
(6)	Adds a new Position Control Unit.
(7)	Deletes a Position Control Unit.

Status Bar

The following information is displayed on the status bar.



View Settings

The view settings can be used to display or hide the toolbar or status bar.

View/Hide Settings

1,2,3...

1. Click **View**.

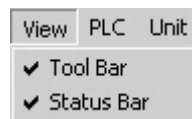

2. If a check appears next to **Toolbar** or **Status Bar**, the corresponding item is displayed. To hide any of these, select **Toolbar** or **Status Bar** to remove the check.

Help

Displaying the Help Contents

- 1,2,3...
1. Select **Help - Help Index**. The table of contents for help will be displayed.
 2. Select an item to display information related to that item.

Displaying CX-Motion-NCF and CX-Server Version Information

Select **Help - About CX-Motion-NCF**. The CX-Motion-NCF and CX-Server version information will be displayed.

3-2-2 Axis Map Setting Window Basic Operation

The basic operations of the Axis Map Setting Window used to make the Position Control Unit settings are explained here.

Starting the Axis Map Setting Window

Select a Position Control Unit in the CX-Motion-NCF Basic Window and select **Unit - Edit Parameters**, or double-click a Position Control Unit.

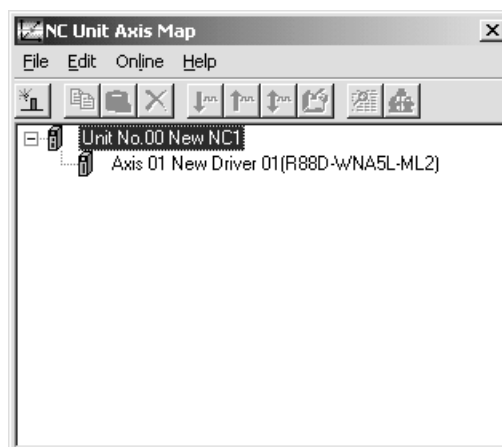

Quitting Axis Map Setting Window

Select **File - Exit**, or click the Close Button at the right top corner of the Axis Map Setting Window.

Axis Map Setting Window

The Axis Map Setting Window is shown below.

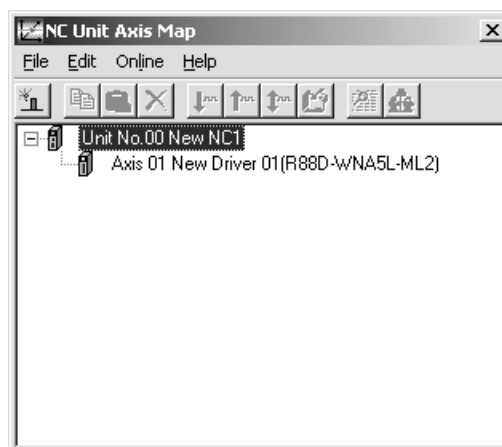

Main Menus

Main menu	Contents	Keyboard shortcut
File	Used, for example, to import or export.	Alt+F
Edit	Used, for example, to add Servo Drives or edit parameters.	Alt+E
Online	Used, for example, to transfer parameters or monitor Position Control Units or axes.	Alt+L
Help	Used to display help and version information.	Alt+H

Main Menu Items

The names and functions for all of the menus are given below. When an item is selected, the dialog box for that function is displayed. Follow the instructions in the dialog box.

Main menu	Item	Contents	Keyboard shortcut	
File	Import	Imports entire Position Control Unit project files or Servo Parameters. The file is to be in CSV format.	---	
	Export	Exports entire Position Control Unit project files or Servo Parameters. The file is to be in CSV format.	---	
	Properties	When a Servo Drive item has been selected, displays the Servo Drive Properties Window. Invalid when no Servo Drive item has been selected.	---	
	Print	Prints out Unit Parameters or Servo Parameters.	Ctrl+P	
	Close	Closes Axis Map Setting Window. Closes all the active Edit Parameters and Monitor Windows.	---	
Edit	New Driver	Displays the New Driver Dialog.	---	
	Edit Parameters	NC Unit	Edits Unit Parameters.	---
		Axis	Edits Servo Parameters.	---
	Copy	Copies an axis.	Ctrl+C	
	Paste	Pastes an axis.	Ctrl+V	
Delete	Deletes the selected Servo Drive.	DEL		

Main menu	Item	Contents	Keyboard shortcut
Online	Download to NC Unit	Executes batch download. Displays the Batch Download Dialog.	---
	Upload from NC Unit	Executes batch upload. Displays the Batch Upload Dialog.	---
	Compare	Executes batch compare. Displays the Batch Compare Dialog.	---
	Write Flash Memory	Writes data to flash memory.	---
	Unit Monitor	Starts Unit Monitor.	---
	Axis Monitor	Starts Axis Monitor.	---
	Test Run	Displays the Test Run Window. Connection status, Servo Lock/Unlock, JOG, etc. can be controlled.	---
	Error Log	Displays error log.	---
	Device Information	Displays device information.	---
	Absolute Encoder Setup	Used to set up an absolute encoder.	---
Help	Help	Displays help.	F1
	About	Displays the version information for the CX-Motion-NCF and Servo Drive database.	---

Toolbar

Functions can be executed directly by clicking the appropriate icon on the toolbar. The functions that can be executed from the toolbar are given below.

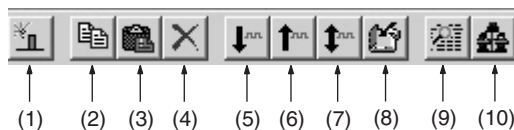

Number	Function
(1)	Adds a new Servo Drive.
(2)	Copy
(3)	Paste
(4)	Remove
(5)	Download to Position Control Unit
(6)	Upload from Position Control Unit
(7)	Compare
(8)	Writes data to flash memory.
(9)	Unit Monitor
(10)	Axis Monitor

Help

Displaying the Help Contents







- 1,2,3... 1. Select **Help - Help**. The table of contents for help will be displayed.
 2. Select an item to display information related to that item.









Displaying CX-Motion-NCF and Servo Drive Database Version Information

Select **Help - About**. The CX-Motion-NCF and Servo Drive database version information will be displayed.

3-3 Operations Listed by Purpose

Operations Listed by Purpose

Function (Purpose)	Operation	Keyboard shortcut	Toolbar icon	Page
Project				
Starting CX-Motion-NCF	Select Start - Programs - OMRON - CX-One - CX-Motion-NCF and select CX-Motion-NCF .	---	---	17
Creating a new project	Select File - New in the CX-Motion-NCF Basic Window.	Ctrl+N		28
Opening a project	Select File - Open in the CX-Motion-NCF Basic Window.	Ctrl+O		44
Saving (overwriting)	Select File - Save in the CX-Motion-NCF Basic Window.	Ctrl+S		44
Saving with a different name	Select File - Save As in the CX-Motion-NCF Basic Window.	---	---	44
Quitting CX-Motion-NCF	Select File - Exit in the CX-Motion-NCF Basic Window.	---	---	18
Adding a Position Control Unit	Select Unit - Add in the CX-Motion-NCF Basic Window.	---		29
Importing Parameters	Select a Position Control Unit in the Axis Map Setting Window and then select File - Import , or right-click the Position Control Unit and select Import from the pop-up menu.	---	---	45
Exporting All the Parameters	Select a Position Control Unit in the Axis Map Setting Window, and then select File - Export , or right-click the Position Control Unit and select Export from the pop-up menu.	---	---	45
Exporting Servo Parameters	Select a Servo Drive in the Axis Map Setting Window, and then select File - Export , or right-click the Servo Drive and select Export from the pop-up menu.	---	---	46
Displaying Servo Drive Properties	Select a Servo Drive in the Axis Map Setting Window and then select File - Properties , or right-click the Servo Drive and select Properties from the pop-up menu.	---	---	---
Opening Axis Map Setting Window	Select a Position Control Unit in the CX-Motion-NCF Basic Window. Select Unit - Edit Parameters , or double-click the Position Control Unit.	---	---	21
Closing Axis Map Setting Window	Select File - Close in the Axis Map Setting Window.	---	---	21
Adding a Servo Drive	In the Axis Map Setting Window, select Edit - New Driver , or right-click a Position Control Unit and select New Driver from the pop-up menu.	---		30
Deleting a Servo Drive	Select a Servo Drive in the Axis Map Setting Window and then select Edit - Delete , or right-click the Servo Drive and select Delete from the pop-up menu.	DEL		32
Printing	Select File - Print in the Axis Map Setting Window.	Ctrl+P	---	46

Function (Purpose)	Operation	Keyboard shortcut	Toolbar icon	Page
Editing data				
Editing Unit Parameters	Select Edit - Edit Parameters - NC Unit , or right-click a Position Control Unit and select Edit Unit Parameters from the pop-up menu in the Axis Map Setting Window.	---	---	34
Editing Servo Parameters	Select Edit - Edit Parameters - Axis** , or right-click a Servo Drive and select Edit Servo Parameters from the pop-up menu in the Axis Map Setting Window.	---	---	37
Jumping between windows	Jumps around over Axis Map Setting Window, Edit Parameter Window, and Monitor Window by clicking the mouse.	Ctrl+Tab or Ctrl+Shift+Tab	---	---
Online operations				
Starting communications with PLC	Select PLC - Online in the CX-Motion-NCF Basic Window.	---		51
Communications setting	Select PLC - Communication Settings in the CX-Motion-NCF Basic Window.	---		50
Batch download	In the Axis Map Setting Window, select Online - Download to NC Unit , or right-click a Position Control Unit and select Download to NC Unit from the pop-up menu.	---		52
Batch upload	In the Axis Map Setting Window, select Online - Upload from NC Unit , or right-click a Position Control Unit and select Upload from NC Unit from the pop-up menu	---		57
Batch compare	In the Axis Map Setting Window, select Online - Compare , or right-click a Position Control Unit and select Compare from the pop-up menu.	---		61
Writing to flash memory	Select Online - Write Flash Memory in the Axis Map Setting Window.	---		66
Monitoring Position Control Unit	In the Axis Map Setting Window, select Online - Unit Monitor , or right-click a Position Control Unit and select Unit Monitor from the pop-up menu.	---		70
Monitoring axis	In the Axis Map Setting Window, select Online - Axis Monitor , or right-click a Position Control Unit or Servo Drive and select Axis Monitor from the pop-up menu.	---		73
Error log	In the Axis Map Setting Window, select Online - Error Log , or right-click a Position Control Unit and select Error Log from the pop-up menu.	---	---	92
JOG	Select Online - Test Run in the Axis Map Setting Window.	---	---	84
Displaying device information (Position Control Unit model and version)	In the Axis Map Setting Window, select Online - Device Information , or right-click a Position Control Unit and select Device Information from the pop-up menu.	---	---	---
Setting up an absolute encoder	In the Axis Map Setting Window, select Online - Absolute Encoder Setup - Axis** , or right-click a Servo Drive and select Absolute Encoder Setup .	---	---	90
Display settings				
Displaying or hiding Toolbar	Select View - Toolbar in the CX-Motion-NCF Basic Window.	---	---	19
Displaying or hiding Status Bar	Select View - Status Bar in the CX-Motion-NCF Basic Window.	---	---	19

Function (Purpose)	Operation	Keyboard shortcut	Toolbar icon	Page
Displaying help				
Displaying help	Select Help - Help Index in the CX-Motion-NCF Basic Window.	F1	---	21
	Select Help - Help In the Axis Map Setting Window.	F1	---	23
Online registration	Select Help - Online Registration in the CX-Motion-NCF Basic Window.	---	---	---
Displaying version information	Select Help - About CX-Motion-NCF	---	---	21

SECTION 4

Creating Projects

This section provides information on creating projects and adding/deleting Position Control Units and Servo Drives.

4-1	Creating a New Project	28
4-2	Adding and Deleting Position Control Units	29
4-3	Adding and Deleting Servo Drives	30

4-1 Creating a New Project

Creating a New Project

Use the following procedure to create a new project in the CX-Motion-NCF Basic Window.

- 1,2,3...
1. In the CX-Motion-NCF Basic Window, select **File - New**, press the **Ctrl+N** Keys, or click  in the toolbar.
 2. The PLC Device Type Window will be displayed. Select the PLC Series to use and click the **OK** Button.

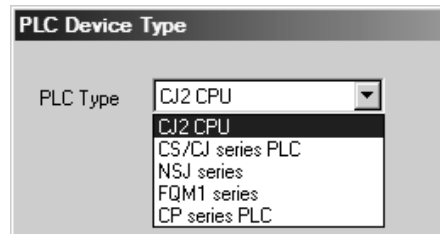

Note To connect the Position Control Unit to a network, select the PLC Series connected to the personal computer directly. If the PLC with the Position Control Unit is selected, the communications settings with the PLC and personal computer may not be set correctly.

3. The PLC will be registered in the project.
When the CX-Motion-NCF is started, a CJ2 CPU Unit will be registered in the project. If the personal computer is connected to a PLC with a CJ2 CPU Unit, use the project that is already being displayed.

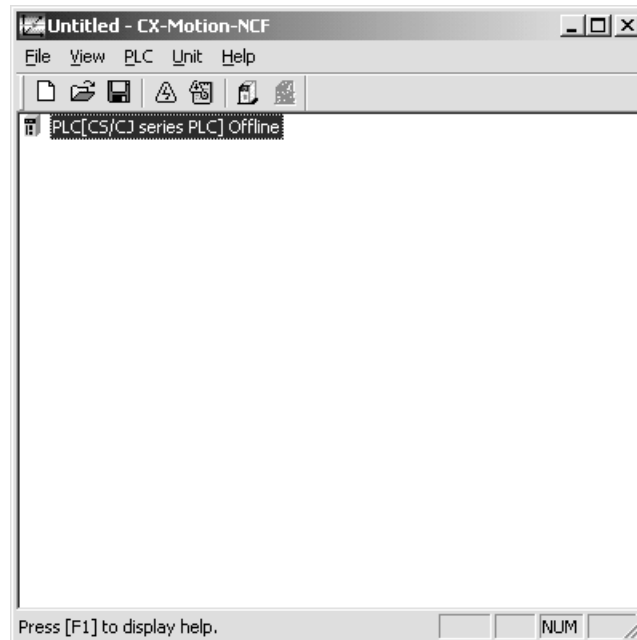

4-2 Adding and Deleting Position Control Units

Adding Position Control Units to Projects

A Position Control Unit can be added to the project.

- 1,2,3... 1. In the CX-Motion-NCF Basic Window, select **Unit - Add**, click  in the toolbar, or right-click and select **Add NC** from the pop-up menu.

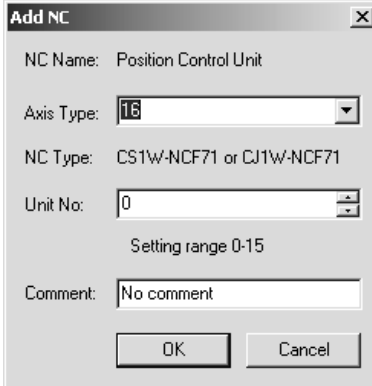

2. Set the axis type.
Select the axis type of the Position Control Unit.
3. Set the unit number.
Select a unit number for the Position Control Unit as a CPU Bus Unit.
4. Enter a comment. The comment may be omitted.
5. Click the **OK** Button.
A Position Control Unit will be added to the project.

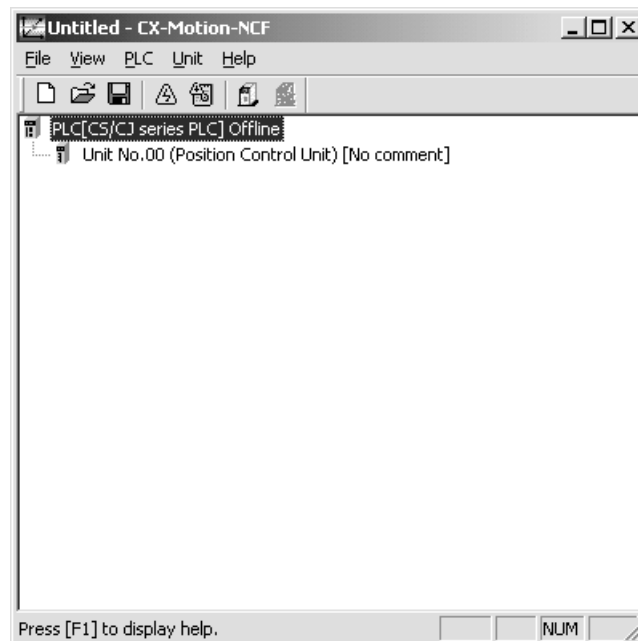

Deleting Position Control Units

- 1,2,3...
1. Selecting the Position Control Unit to be deleted in the CX-Motion-NCF Basic Window, and then select **Unit - Delete**, click , or right-click and select **Delete** from the pop-up menu.
 2. A dialog box saying "Delete the selected Unit. Proceed?" will be displayed. Click the **OK** Button.

4-3 Adding and Deleting Servo Drives

Adding Servo Drives to Position Control Units

Select a Position Control Unit in the CX-Motion-NCF Basic Window, and then select **Unit - Edit Parameters** or double-click a Position Control Unit to display the Axis Map Setting Window. In the Axis Map Setting Window, add a new Servo Drive.

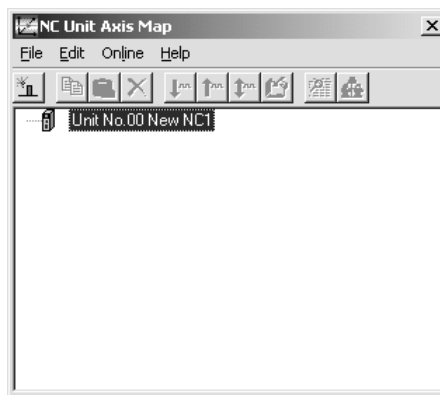

- 1,2,3...
1. Select **Edit - New Driver**, click  in the toolbar, or right-click the Position Control Unit and select **New Driver** from the pop-up menu.

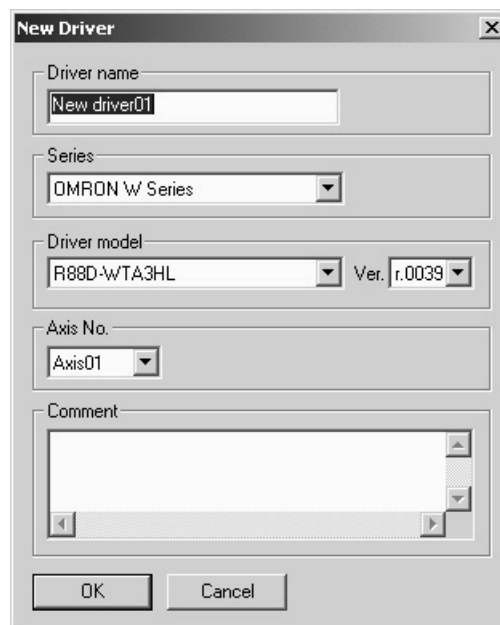

2. Enter the Servo Drive name.
Up to 32 one-byte characters can be entered.

3. Select the Series.
Click the drop-down list and select an appropriate series.
Note Select *OMRON W Series* when using an OMRON R88D-WT□ W-series Servo Drive with a Yaskawa JUSP-NS115 MECHATROLINK-II Application Module. Select *OMRON W Series (Built-in Communications)* when using an OMRON R88D-WN□-ML2 W-series Servo Drive with Built-in MECHATROLINK-II Communications. Select *OMRON SMARTSTEP Junior with Built-in Communications* when using an OMRON SMARTSTEP Junior Servo Drive with Built-in MECHATROLINK-II Communications (R7D-ZN□-ML2). Select *OMRON G Series (Built-in Communications)* when using an OMRON G-series Servo Drive with Built-in MECHATROLINK-II Communications (R88D-GN□-ML2). Select *OMRON G5 Series (Built-in Communications)* when using an OMRON G5-series Servo Drive with Built-in MECHATROLINK-II Communications (R88D-KN□-ML2).
4. Select the Servo Drive Model.
Click the drop-down list and select an appropriate Servo Drive model. The Servo Drive models in the list depends on the selected Series.
5. Select the Version.
Click the drop-down list and select an appropriate version. The Servo Drive versions in the list depends on the selected Servo Drive model.
6. Set the Axis No.
Click the drop-down list and select an axis number. The axis numbers that are already in use will not be displayed.
7. Enter the Comment.
Up to 256 one-byte characters can be entered. The comment may be omitted.
8. Click the **OK** Button.
A new Servo Drive will be added to the Position Control Unit.

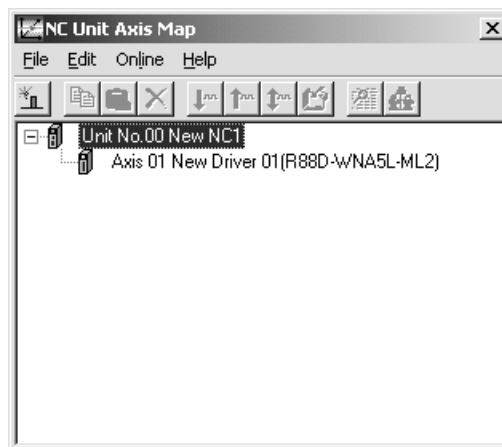

Copying Servo Drives to Position Control Units

If a Servo Drive that has been registered under a Position Control Unit in the Axis Map Setting Window is copied and pasted on the same Position Control Unit, a new Servo Drive will be added with the lowest axis number that is not in use. If a Servo Drive that has been registered under a Position Control Unit is copied and pasted on another Servo Drive (which must be registered in advance), the parameters of the copied Servo Drive will overwrite the other Servo Drive.

Deleting Servo Drives from Position Control Units

A Servo Drive that has been registered under a Position Control Unit can be deleted.

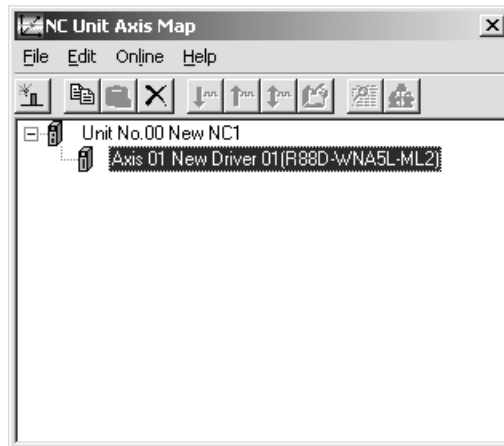

1,2,3...

1. Select the Servo Drive to be deleted in the Axis Map Setting Window, and then select **Edit - Delete**, click in the toolbar, press the **Delete** Key, or right-click the Servo Drive and select **Delete** from the pop-up menu.



2. Click the **OK** Button.
The Servo Drive will be deleted from the Position Control Unit.

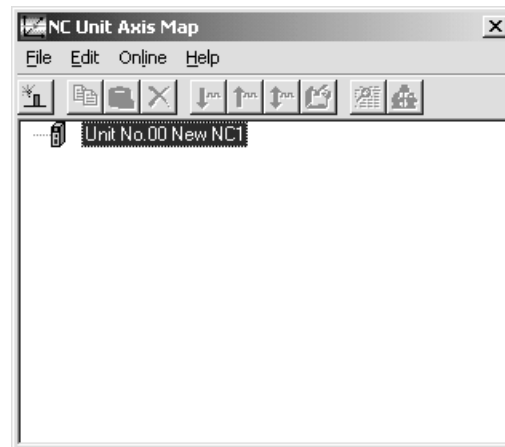

SECTION 5

Editing Data

This section describes the operations used to edit data.

- 5-1 Editing Unit Parameters 34
 - 5-1-1 Editing Memory Area Parameters 35
 - 5-1-2 Editing Communications Parameters 36
 - 5-1-3 Editing Axis Parameters 37
- 5-2 Editing Servo Parameters 39

5-1 Editing Unit Parameters

The methods used to edit data are described in this section. For details on the setting contents, Unit parameters, and Servo Parameters, refer to the *CS1W-NC/271/471/F71/CJ1W-NC271/471/F71 Position Control Units Operation Manual* (Cat. No. W426).

- 1,2,3...
1. Select **Edit - Edit Parameters - NC Unit** in the Axis Map Setting Window, double-click a Position Control Unit, or right-click and select **Edit Unit Parameters** from the pop-up menu. The Edit Unit Parameter Window will be displayed.

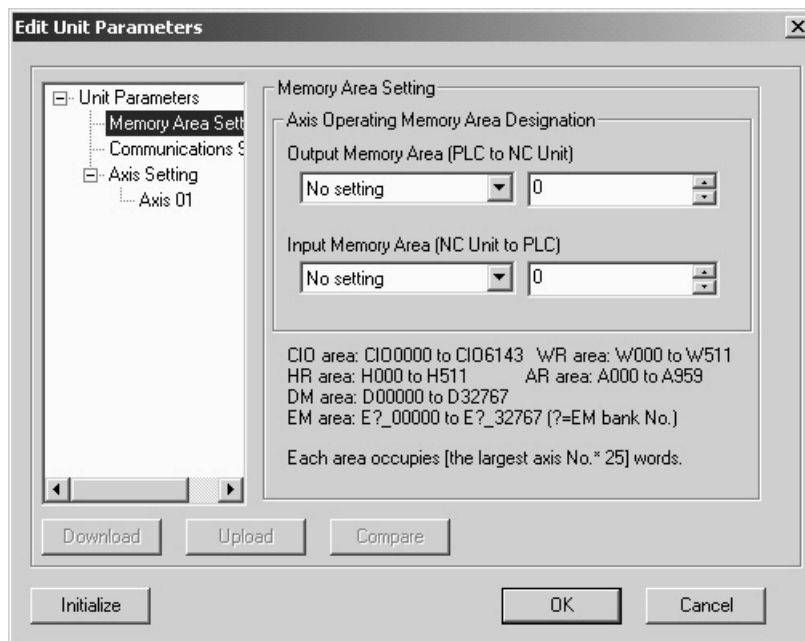

Item	Explanation
Download	Downloads all the parameters that are set in the Edit Unit Parameter Window to a Position Control Unit. (See notes 1 and 2.)
Upload	Uploads all the parameters that are set in the Edit Unit Parameter Window from a Position Control Unit. (See notes 1 and 2.)
Compare	Compares all the parameters that are set in the Edit Unit Parameter Window with the parameters saved in a Position Control Unit. (See notes 1 and 2.)
Initialize	Initializes all the parameters (see note 2) that are set in the Edit Unit Parameter Window to their default settings.
OK	Saves the parameters that are set in the Edit Unit Parameter Window.
Cancel	Cancels the parameters that are set in the Edit Unit Parameter Window.

- Note**
- (1) It can be executed only when the connection to the PLC has been established in the CX-Motion-NCF Basic Window.
 - (2) “All the parameters that are set in the Edit Unit Parameter Window” indicates the parameters that are set in Memory Area Setting, Communications Setting, and Axis Setting.

5-1-1 Editing Memory Area Parameters

Edit Memory Area Parameter Window

Select **Memory Area Setting** from the tree.

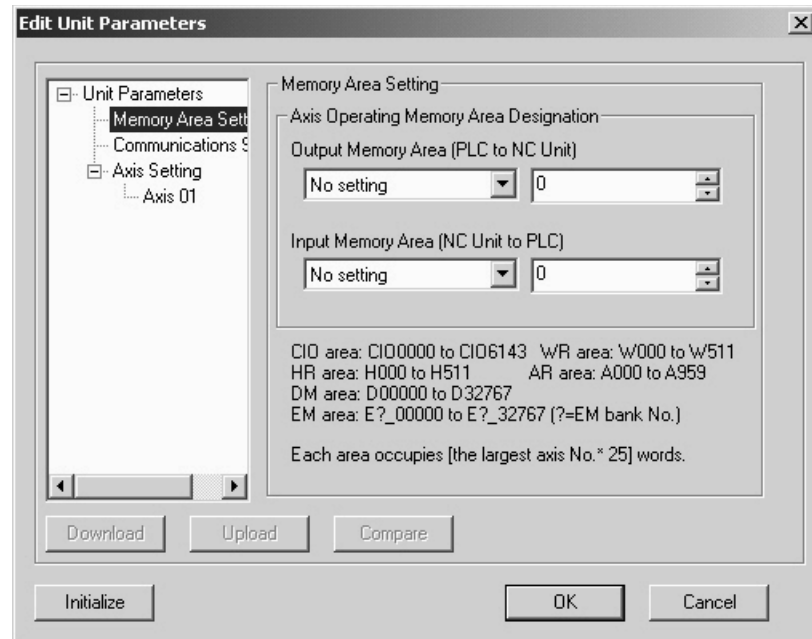

Editing Memory Area Parameters

- 1,2,3...**
1. Set the Output Memory Area (PLC to Position Control Unit).
Click the drop-down list of the Output Memory Area (PLC to Position Control Unit) and select an appropriate area type from the list.
In the right box, set the beginning address of the specified area type. The setting range varies depending on the selected area type and the largest axis No. of the registered axes. When a value out of the range is entered, the value will be displayed in red. Enter a value within the range.
 2. Set the Input Memory Area (Position Control Unit to PLC)
Click the drop-down list of the Input Memory Area (Position Control Unit to PLC) and select an appropriate area type from the list.
In the right box, set the beginning address of the specified area type. The setting range varies depending on the selected area type and the largest axis No. of the registered axes. When a value out of the range is entered, the value will be displayed in red. Enter a value within the range.

Note When selecting the same area type for the Output and Input Memory Areas, make sure to set the appropriate beginning addresses so that the areas do not overlap. Do not set EM banks that do not exist in the PLC being used as the areas used for the Output and Input Memory Areas.

5-1-2 Editing Communications Parameters

Edit Communications Parameters Window

Select **Communications Setting** from the tree.

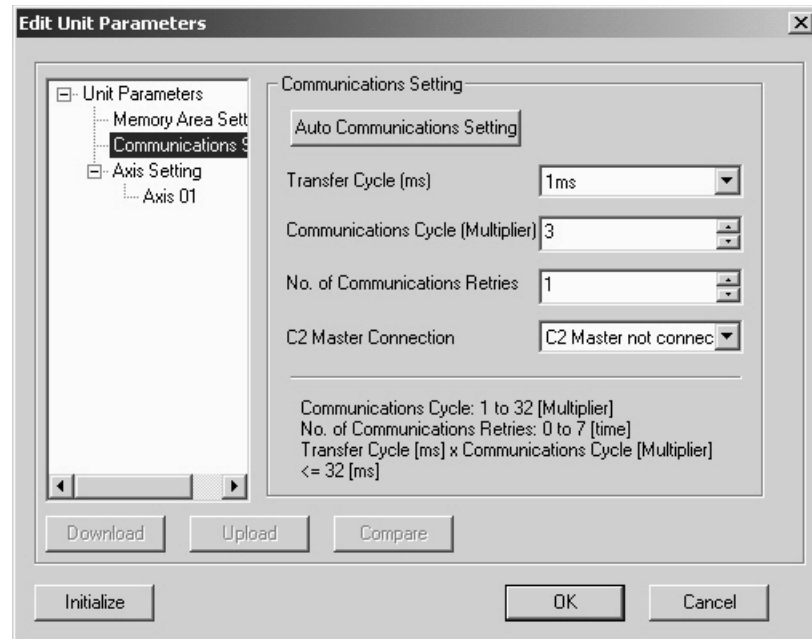

Editing Communications Parameters

For details of the communications settings, refer to SECTION 6 MECHATROLINK in the *CS1W-NCF71/CJ1W-NCF71 Position Control Units Operation Manual* (Cat. No. W426).

1,2,3...

1. Set Transfer Cycle.
Click the drop-down list of the Transfer Cycle and select an appropriate Transfer Cycle.
2. Set Communications Cycle.
The setting range is between 1 and 32. The set value is used as the multiplier with which the Transfer Cycle is multiplied. When a value out of the setting range is entered, the value will be displayed in red. Enter a value within the range.
3. Set No. of Communications Retries.
The setting range is between 0 to 7. When a value out of the setting range is entered, the value will be displayed in red. Enter a value within the range.
4. Set C2 Master Connection.
Click the drop-down list of the C2 Master Connection and select whether the C2 Master is connected or not.

Note

- (1) Set the Communications and Transfer Cycles so that the following expression is satisfied: Transfer Cycle × Communications Cycle (Multiplier) ≤ 32 ms
- (2) When connecting to a combination of a W-series Servo Drive and the JUSP-NS115, set the communications cycle to an integer multiple of 1.0 ms.
- (3) When connecting to a W-series Servo Drive with Built-in Communications, set the communications cycle to an integer multiple of 0.5 ms.
- (4) When connecting to a SMARTSTEP Junior with Built-in Communications, set the transfer cycle to 1.0 ms or more.

- (5) When connecting to a combination of a W-series Servo Drive and the JUSP-NS115, to a W-series Servo Drive with built-in communications, to a SMARSTEP Junior Servo Drive (with built-in communications), to a G-series Servo Drive (with built-in communications), or to a G5-series Servo Drive (with built-in communications), set the transfer cycle to 4 ms or less.

Automatic Communications Setting

By clicking the **Auto Communications Setting** Button, the Communications and Transfer Cycles corresponding to the largest axis No. registered in the Position Control Unit are set to their minimum values.

For details on the values of the Communications Parameters set in Automatic Communications Setting, refer to 6-2-3 *MECHATROLINK Communications Settings* in the *CS1W-NCF71/CJ1W-NCF71 Position Control Units Operation Manual* (Cat. No. W426).

Largest axis No.	Transfer Cycle	Communications Cycle	No. of Communications Retries	C2 Master Connection
1 to 4	1.0 ms	× 1 (1.0 ms)	1	No C2 Master
5 to 8	1.0 ms	× 2 (2.0 ms)	1	No C2 Master
9 to 10	2.0 ms	× 1 (2.0 ms)	1	No C2 Master
11 to 16	2.0 ms	× 2 (4.0 ms)	1	No C2 Master

5-1-3 Editing Axis Parameters

Edit Axis Parameter Window

- 1,2,3... 1. To edit Axis Parameters, click the **Plus** Icon left of the Axis Setting in the tree in the Edit Unit Parameter Window at first. The registered axes will be displayed.

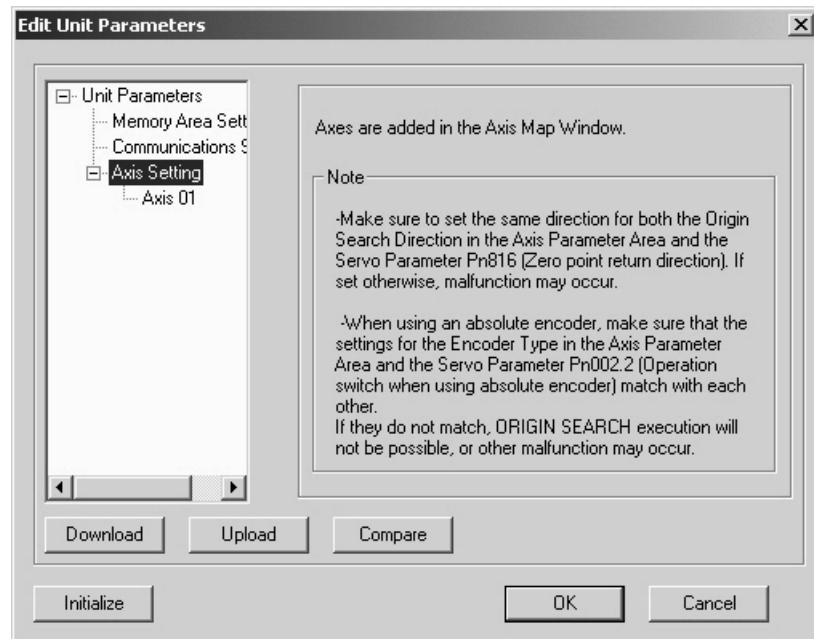

Note When no axes are registered, the Axis Parameters cannot be edited in the Edit Unit Parameter Window. Register axes in the Axis Map Setting Window first and edit the Axis Parameters. Once axes are registered in the Axis Map Setting Window, they will be automatically displayed in the Edit Unit Parameter Window.

2. Select **Axis**□□, where □□ is the number of the axis to be edited (□□: 01 to 16).

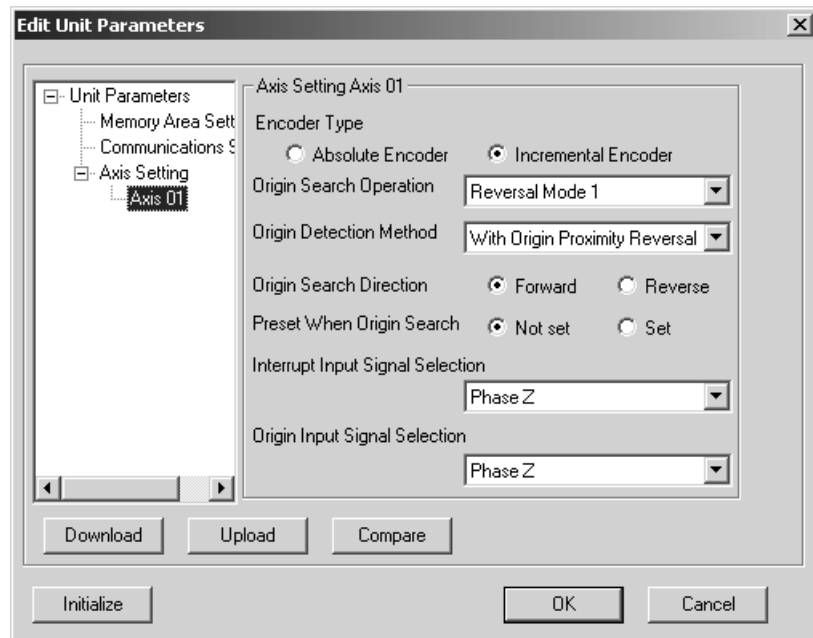

Editing Axis Parameters

- 1,2,3...**
1. Select the Encoder Type.
Select from either *Absolute Encoder* or *Incremental Encoder*.
 2. Set the Origin Search Operation.
Select one of the following:
Reversal Mode 1, Reversal Mode 2, Single-direction Mode, or Reversal Mode 3.
 3. Set the Origin Detection Method.
Select either *With Origin Proximity Reversal, No Origin Proximity Reversal, or Not Use Origin Proximity.*
 4. Set the Origin Search Direction.
Select either *Forward* or *Reverse*.
 5. Set the Preset When Origin Search.
Select either *Not Set* or *Set*.
 6. Select the Interrupt Input Signal.
Click the drop-down list and select a signal used as the Interrupt Input Signal.
 7. Select the Origin Input Signal.
Click the drop-down list and select a signal used as the Origin Input Signal.

- Note**
- (1) Make sure that the same direction is set for Origin Search Direction in the Axis Parameters and Zero Point Return Direction in the Servo Parameters. Setting different directions may result in a malfunction. (The Origin Search Direction parameters are as follows: W Series (with and without built-in communications) and SMARTSTEP Junior (with built-in communications): Pn816.0, G Series (with built-in communications): Pn204, G5 Series (with built-in communications): Pn816.)
 - (2) When using an absolute encoder, make sure that the settings for the Encoder Type in the Axis Parameters and Operation Switch when Using Absolute Encoder in the Servo Parameters match. If the settings do not

match, ORIGIN SEARCH execution will not be possible, or another malfunction may occur. (The Using Absolute Encoder parameters are as follows: W Series (with and without built-in communications): Pn002.2, G Series (with built-in communications): Pn00B, G5 Series (with built-in communications): Pn00F.)

- (3) When setting Reversal Mode 3 for the Origin Search Operation, *Not Use Origin Proximity* cannot be set for the Origin Detection Method.
- (4) When using an Absolute Encoder and the *Preset When Origin Search* setting, only Reversal Mode 1 can be set for the Origin Search Operation.

Quitting Editing

Click the **OK** Button. Once all the editing is completed, click the **OK** Button to finalize the edited data.

To cancel the edited data, click the **Cancel** Button.

5-2 Editing Servo Parameters

In the Axis Map Setting Window, select **Edit - Edit Parameters - Axis**□□, double-click an axis to be edited, or right-click an axis to be edited and select **Edit Servo Parameters** from the pop-up menu. (□□: 01 to 16) The Edit Servo Parameter Window will be displayed.

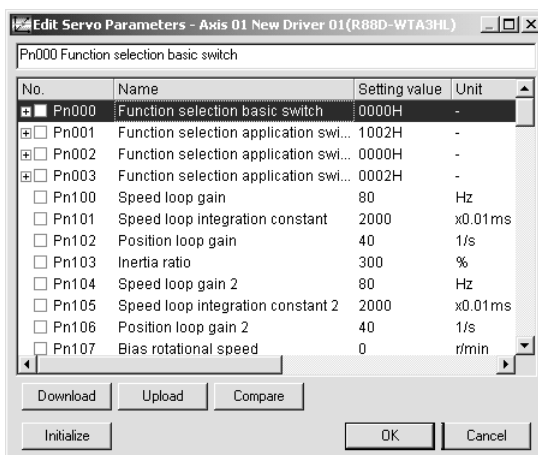

Item	Explanation
Download	Downloads Servo Parameters to a Servo Drive
Upload	Uploads Servo Parameters from a Servo Drive.
Compare	Compares the Servo Parameters on the computer with the ones in the Servo Drive.
Initialize	Initializes the Servo Parameters to their default settings.
OK	Saves the parameters that are set in the Edit Servo Parameter Window.
Cancel	Cancels the parameters that are set in the Edit Servo Parameter Window.

Editing Servo Parameters

- 1,2,3... 1. Select a parameter to be edited.
 Edit a parameter either by entering a value or by selecting a value from the drop-down list for each bit of the parameter.
 For parameters whose bits are to be set, click the **Plus** Icon on the left to display the parameters for each bit.

Entering Value Directly for Parameter

Move to the Setting Value Column of the parameter to be edited using the mouse or cursor keys.

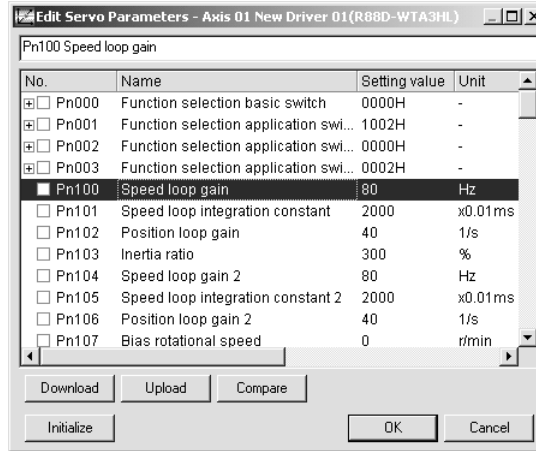

Selecting Value from Drop-down List for Each Bit of Parameter

Move to the Setting Value Column of the parameter to be edited using the mouse or cursor keys.

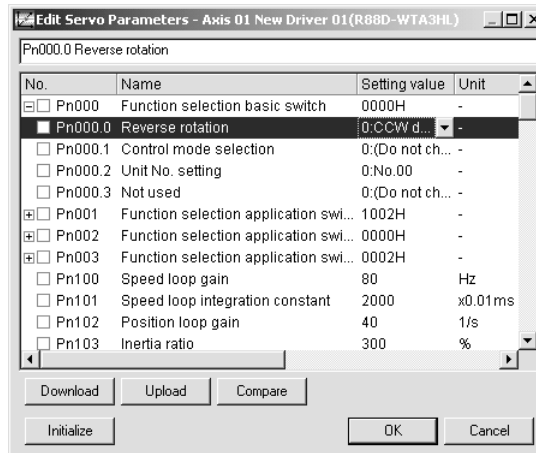

2. Set a Value.

Set a value either by entering a value directly or by selecting a value from the drop-down list.

Entering Value Directly for Parameter

Either enter a value after double-clicking the Setting Value Column or enter a value directly. After entering a value, press the **Enter** Key to save the setting. Once the setting value is changed, the check box of the parameter will show a check.

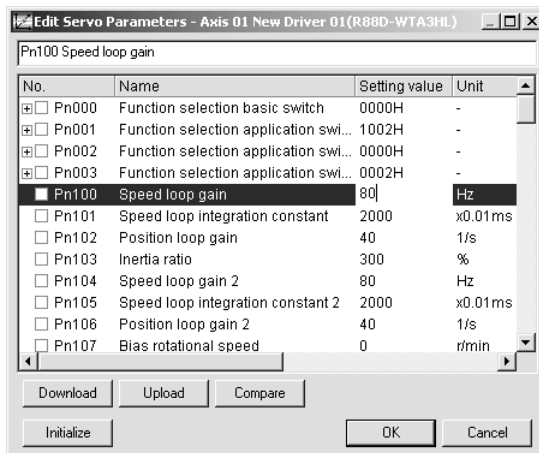

Selecting Value from Drop-down List for Each Bit of Parameter

Select a value from the drop-down list. Once the setting value is changed, the check box of the parameter and each bit will show a check.

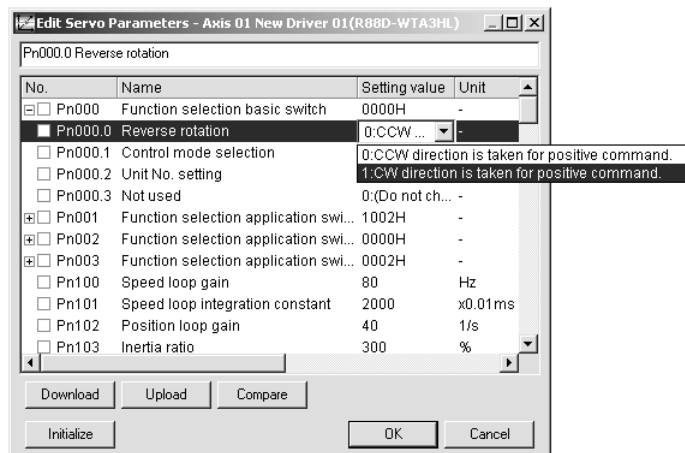

Initializing Servo Parameters

Click the **Initialize** Button. A confirmation dialog box will be displayed. Click the **OK** Button. All the parameters will be set back to their default settings. Once initialization is completed, checks in the check box will be cleared.

Quitting Editing

Click the **OK** Button. Once all the editing is completed, click the **OK** Button to save the edited data. To cancel the edited data, click the **Cancel** Button.

SECTION 6

Saving and Reading Projects

This section describes the operations used to save and read newly created projects.

6-1	Saving Project	44
6-2	Reading Project	44
6-3	Import	45
6-4	Export	45
6-5	Print	46

6-1 Saving Project

Saving Project

To save a project, select **File - Save** or **File - Save As** in the CX-Motion-NCF Basic Window.

When editing a project that was saved before and saving it again with the same name, select **File - Save**. The project will be overwritten. When saving a new project or saving a project with a different name, select **File - Save As**.

Saving Project with Name

1,2,3...

1. Select **File - Save As**. The following window will be displayed.

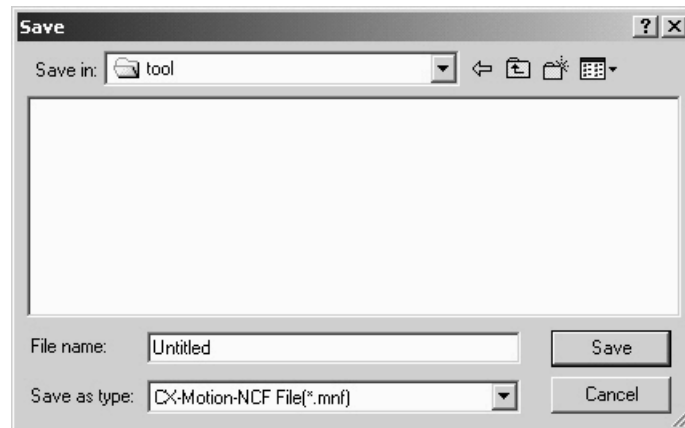

2. Enter or select the folder to be saved in, the file name, and the file type (use the default file type: *.mnf), and then click the **Save** Button.

6-2 Reading Project

Reading Project

To read a project that has already been saved, select **File - Open** in the CX-Motion-NCF Basic Window.

1,2,3...

1. Select **File - Open** in the CX-Motion-NCF Basic Window.

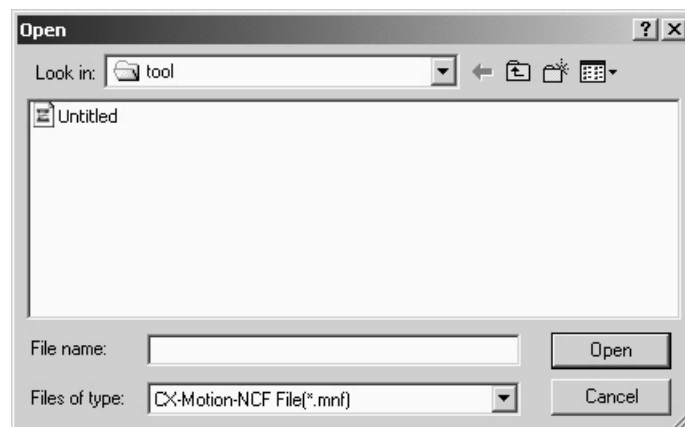

2. From the *Look in* drop-down list, select the drive and folder to which the file was saved.
3. Enter the project name, or select one from the file list. Set the File of type: field to *.mnf.
4. Click the **Open** Button.

6-3 Import

Importing File

Files saved in CSV format can be imported as project data.

If a CSV file contains Unit and Servo Parameters, the axis map in the imported file will be adopted.

If a CSV file contains Servo Parameters only, a new Servo Drive will be added to the axis map. In this case, the lowest axis No. not in use will be allocated to the Servo Drive automatically.

In the Axis Map Setting Window, select **File - Import**, or right-click a Position Control Unit and select **Import** from the pop-up menu.

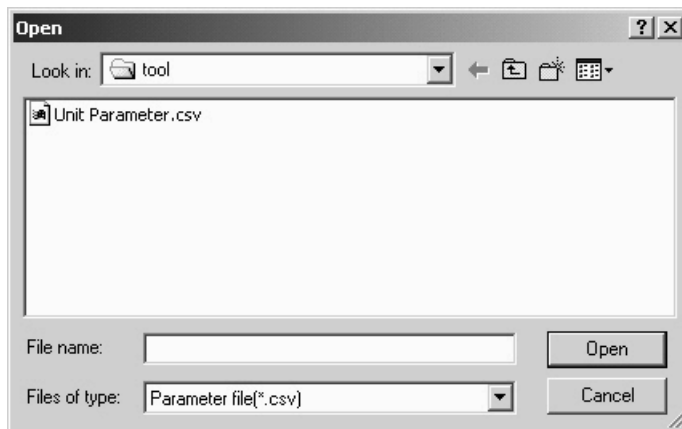

6-4 Export

Exporting All Data

Unit Parameters and registered Servo Parameters can be saved in CSV format.

Select a Position Control Unit in the Axis Map Setting Window, and then select **File - Export**, or right-click the Position Control Unit and select **Export** from the pop-up menu.

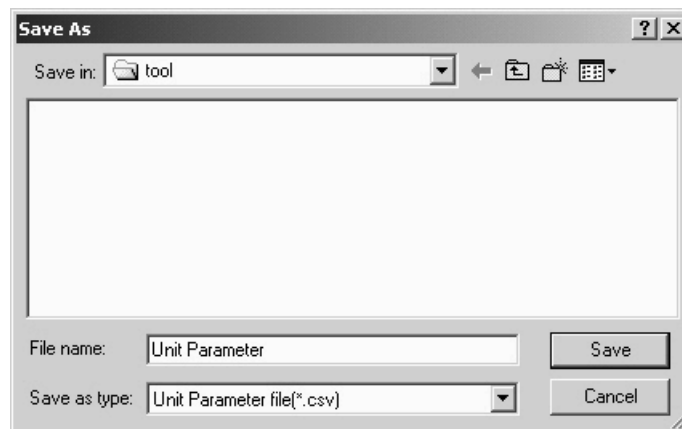

Note Files exported from CX-Motion-NCF version 1.4 or higher cannot be imported to CX-Motion-NCF version 1.3 or lower. Set the *Save as type* Box to *Unit Parameter file in Ver1.3 or lower* to export a file that can be imported to CX-Motion-NCF version 1.3 or lower. *Unit Parameter file in Ver1.3 or lower* can be set only when the Unit is the CS1W-NCF71/CJ1W-NCF71 (the axis type is 16).

Exporting Servo Parameters Alone

Selected Servo Parameters can be saved in CSV format.

Select a Servo Drive in the Axis Map Setting Window, and then select **File - Export**, or right-click the Servo Drive and select **Export** from the pop-up menu.

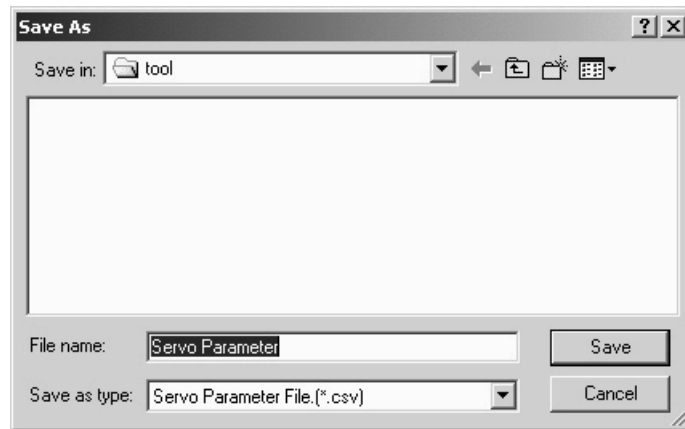

6-5 Print

Printing Procedure

- 1,2,3...
1. In the Axis Map Setting Window, select **File - Print**. The following window will be displayed.

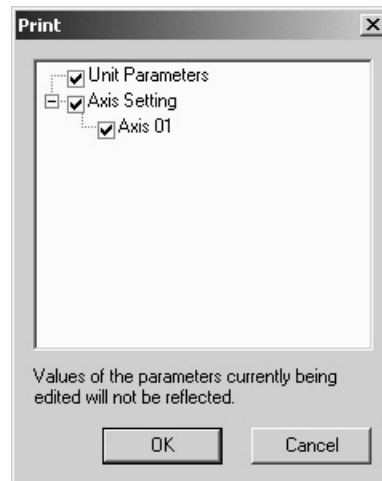

2. Select parameters to be printed out and click the **OK** Button.
3. The Print Dialog Box will be displayed. Select a printer, specify the number of copies, and make appropriate page setup. Then click the **OK** Button.

Note Parameters that are being edited will not be reflected in printing. To reflect the parameters in printing, close the Edit Parameter Window and then select **File - Print**.

Print Samples

An example of printed Unit Parameters is shown below.

2006/10/06 (1 / 1)

Unit No.00 : New NC1
 Comment No comment

Memory Area Setting

Name	Setting Value
Output Memory Area	No setting 0
Input Memory Area	No setting 0
Scan List Setting	
Axis 01	Servo Driver (R7D-ZN01H-ML2 Version 0001H)
Axis 02	Servo Driver (R88D-WNA5L-ML2 Version 0018H)
Axis 03	Servo Driver (R88D-WTA3HL Version 0039H)
Axis 04	Not used
Axis 05	Not used
Axis 06	Not used
Axis 07	Not used
Axis 08	Not used
Axis 09	Not used
Axis 10	Not used
Axis 11	Not used
Axis 12	Not used
Axis 13	Not used
Axis 14	Not used
Axis 15	Not used
Axis 16	Not used

Communications Setting

Name	Setting Value
Transfer Cycle	1ms
Communications Cycle	3 [multiplier]
No. of Communications	1
C2 Master Connection	C2 Master not connected

Axis Setting

Name	Axis 1	Axis 2	Axis 3	Axis 4
Interrupt Input Signal	Phase Z	Phase Z	Phase Z	
Origin Input Signal S	Phase Z	Phase Z	Phase Z	
Origin Search Operati	Reversal Mode 1	Reversal Mode 1	Reversal Mode 1	
Origin detection meth	With Origin Proxim	With Origin Proxim	With Origin Proxim	
Preset when Origin se	Not set	Not set	Not set	
Origin Search Directi	Forward	Forward	Forward	
Encoder Type	Incremental Encode	Incremental Encode	Incremental Encode	
Name	Axis 5	Axis 6	Axis 7	Axis 8
Interrupt Input Signal				
Origin Input Signal S				
Origin Search Operati				
Origin detection meth				
Preset when Origin se				
Origin Search Directi				
Encoder Type				
Name	Axis 9	Axis 10	Axis 11	Axis 12
Interrupt Input Signal				
Origin Input Signal S				
Origin Search Operati				
Origin detection meth				
Preset when Origin se				
Origin Search Directi				
Encoder Type				
Name	Axis 13	Axis 14	Axis 15	Axis 16
Interrupt Input Signal				
Origin Input Signal S				
Origin Search Operati				
Origin detection meth				
Preset when Origin se				
Origin Search Directi				
Encoder Type				

An example of printed Servo Parameters is shown below. The setting value 0000H is expressed in hexadecimal. Other values are expressed in decimal.

Axis 01		2004/07/15	(2 / 7)
Driver Name	New Driver 01		
Model	R88D-WTA3HL		
Version	0039H		
Comment			

No.	Name	Setting Valu	Unit
Pn000	Function selection basic switch	0010H	
Pn001	Function selection application switch 1	1002H	
Pn002	Function application selection switch 2	0000H	
Pn003	Function selection application switch 3	0002H	
Pn100	Speed loop gain	80	Hz
Pn101	Speed loop integration constant	2000	x0.01ms
Pn102	Position loop gain	40	1/s
Pn103	Inertia ratio	300	%
Pn104	Speed loop gain 2	80	Hz
Pn105	Speed loop integration constant 2	2000	x0.01ms
Pn106	Position loop gain 2	40	1/s
Pn107	Bias rotational speed	0	r/min
Pn108	Bias addition band	7	Command unit
Pn109	Feed forward amount	0	%
Pn10A	Feed forward command filter	0	x0.01ms
Pn10B	Speed control setting	0004H	
Pn10C	P control switching (torque command)	200	%
Pn10D	P control switching (speed command)	0	r/min
Pn10E	P control switching (acceleration command)	0	10r/min/s
Pn10F	P control switching (deviation pulse)	10	Command unit
Pn110	Online auto-tuning setting	0012H	
Pn111	Speed feedback compensation gain	100	%
Pn124	Automatic gain switching timer	100	ms
Pn125	Automatic gain switching width (amount of	7	Command unit
Pn200	Position control setting 1	0100H	
Pn201	Encoder divider rate	1000	Pulses/rotation
Pn202	Electronic gear ratio G1 (numerator)	4	
Pn203	Electronic gear ratio G2 (denominator)	1	
Pn205	Absolute encoder multi-turn limit setting	65535	Rotations
Pn206	Number of fully-closed encoder pulses	16384	Pulses/rotation
Pn207	Position Control Setting 2	0010H	
Pn217	Command pulse factor	1	Factor
Pn218	Position control setting 3	0000H	
Pn300	Speed command scale	1000	0.01 V/ No. rated ro
Pn301	No. 1 internal speed setting	100	r/min
Pn302	No. 2 internal speed setting	200	r/min
Pn303	No. 3 internal speed setting	300	r/min
Pn304	Jog speed	500	r/min
Pn305	Soft start acceleration time	0	ms
Pn306	Soft start deceleration time	0	ms
Pn307	Speed command filter time constant	40	x0.01ms
Pn308	Speed feedback filter time constant	0	x0.01ms
Pn400	Torque command scale	30	0.1 V/ rated torque
Pn401	Torque command filter time constant	40	x0.01ms
Pn402	Forward torque limit	350	%
Pn403	Reverse torque limit	350	%
Pn404	Forward rotation external current limit	100	%
Pn405	Reverse rotation external current limit	100	%
Pn406	Emergency stop torque	350	%

SECTION 7

Transferring and Comparing Data

This section describes the operations used to transfer or compare data between the personal computer and Position Control Unit/Servo Drive, and to write data transferred to the Position Control Unit to the Position Control Unit's flash memory.

Note Make sure that the personal computer is connected to the PLC via a connecting cable and that online communications are enabled before transferring or comparing data, or writing data to flash memory.

7-1	Initial Setting for Connecting Online	50
7-2	Setting/Changing Communications Specific	50
7-3	Downloading Data	52
7-3-1	Batch Downloading	52
7-3-2	Downloading Unit Parameters	54
7-3-3	Downloading Servo Parameters	56
7-4	Uploading Data	57
7-4-1	Batch Uploading	57
7-4-2	Uploading Unit Parameters	59
7-4-3	Uploading Servo Parameters	60
7-5	Comparing Data	61
7-5-1	Batch Comparing	61
7-5-2	Comparing Unit Parameters	63
7-5-3	Comparing Servo Parameters	64
7-6	Writing to Flash Memory	66

7-1 Initial Setting for Connecting Online

Initial Settings for CPU Unit and Position Control Unit

- 1,2,3...
1. Set the unit number for the Position Control Unit (using the rotary switch on the front panel)
 2. Set the DIP switch on the CPU Unit or the Controller Section of the NSJ Controller.
 - a. For Communications via Toolbus:
 - When using the peripheral port, set SW4 to OFF, or set SW4 to ON and make appropriate setting of PLC Setup (set the PLC Setup Address 160 on the Programming Console to 0400 Hex).
 - When using the RS-232C port, set SW5 to ON, or set SW5 to OFF and make appropriate setting of PLC Setup (set the PLC Setup Address 160 on the Programming Console to 0400 Hex).
 - b. For Communications via SYSMAC WAY (Host Link):
 - When using the peripheral port, set SW4 to ON, or set SW4 to OFF and make appropriate setting of PLC Setup. (Set the PLC Setup Address 144 on the Programming Console to its default, 0000 Hex. If the default setting has not been changed, leave the setting as it is.)
 - When using the RS-232C port, set SW5 to OFF, or set SW5 to ON and make appropriate setting of PLC Setup. (Set the PLC Setup Address 160 on the Programming Console to its default, 0000 Hex. If the default setting has not been changed, leave the setting as it is.)
 3. Create the I/O tables (using the CX-Programmer or a Programming Console).

7-2 Setting/Changing Communications Specific

Communications Setting

- 1,2,3...
1. In the CX-Motion-NCF Basic Window, select **PLC - Communications Setting**, click  in the toolbar, or right-click and select **Communications Setting** from the pop-up menu. The following dialog box will be displayed.

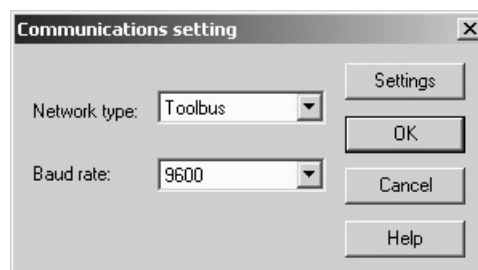

2. Select the Network Type.
Click the drop-down list of the Network Type and select an appropriate network type.
3. Select the Baud Rate.
Click the drop-down list of the Baud Rate and select an appropriate baud rate.
4. Detailed Settings
For more detailed settings, click the **Settings** Button.

Setting the Network Tab Page

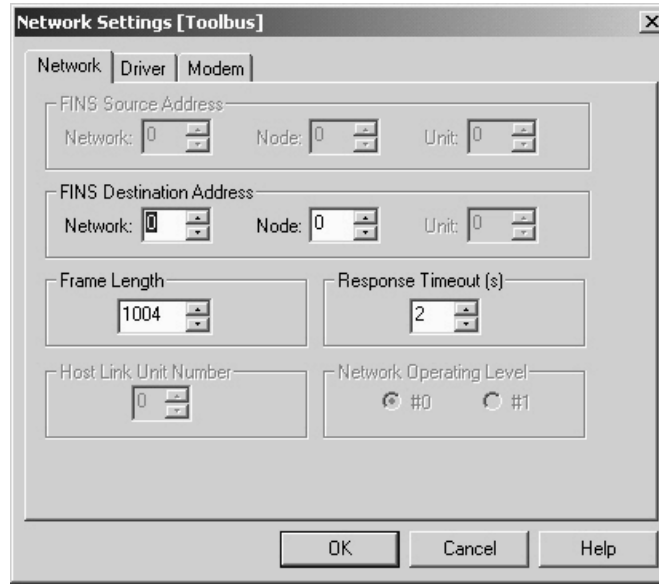

Setting the Driver Tab Page

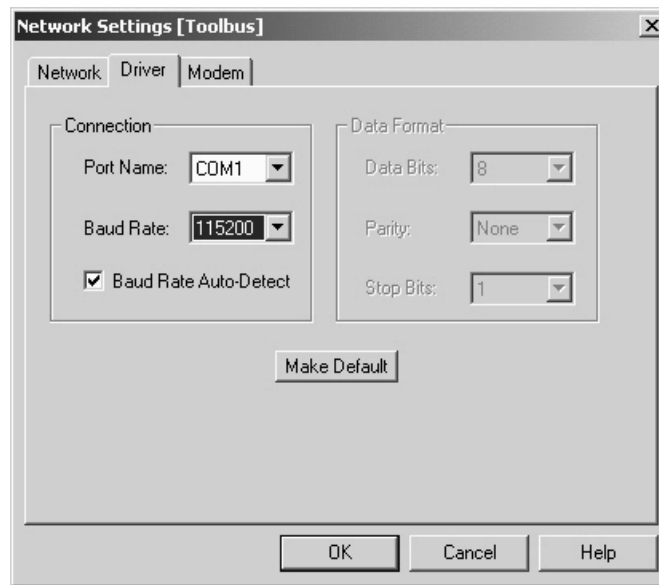

Click the **OK** Button.

Ends the detailed settings and returns to the Communications Setting Window.

5. Click the **OK** Button.
Ends the communications setting.

Connecting to PLC

In the CX-Motion-NCF Basic Window, select **PLC - Online**, click  in the toolbar, or right-click the PLC and select **Online** from the pop-up menu.

7-3 Downloading Data

The object of downloading varies depending on the operation method.

Batch Downloading	Downloads Unit Parameters and Servo Parameters of all the Servo Drives registered in the Axis Map Setting Window.
Downloading Unit Parameters	Downloads Unit Parameters.
Downloading Servo Parameters	Downloads Servo Parameters.

- Note** Comments are not downloaded to the Unit.
- Note** Before starting MECHATROLINK communications, make sure that the PLC is in the PROGRAM Mode. Otherwise, the axis may start moving suddenly due to the ladder execution.
 Before disconnecting MECHATROLINK communications, make sure that the axis is not operating. Disconnecting MECHATROLINK communications will put the operating axis in the Servo Free state.
 Before restarting the Position Control Unit, make sure that the axis is not operating. Restarting the Position Control Unit will put the operating axis in the Servo Free state.

7-3-1 Batch Downloading

- 1,2,3... 1. In the Axis Map Setting Window, select **Online - Download to NC Unit**, click  in the toolbar, or right-click a Position Control Unit and select **Download to NC Unit** from the pop-up menu.

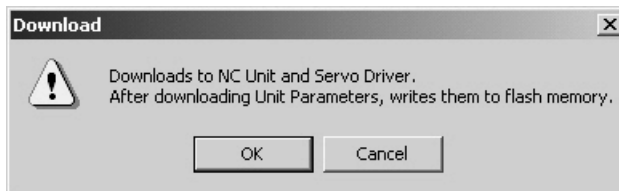

2. Click the **OK** Button.
 Cancels all the parameters being edited and closes the Edit Windows.

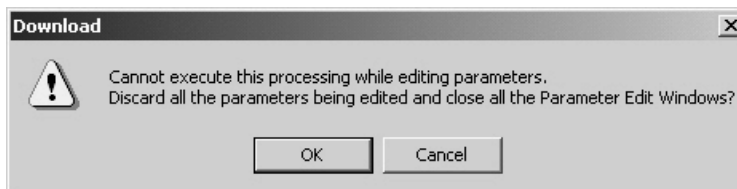

- Click the **OK** Button to start downloading Unit Parameters to the Position Control Unit. Clicking the **Cancel** Button during the download will cancel downloading, however, the parameters that were downloaded before the cancellation will already be downloaded to the Position Control unit.

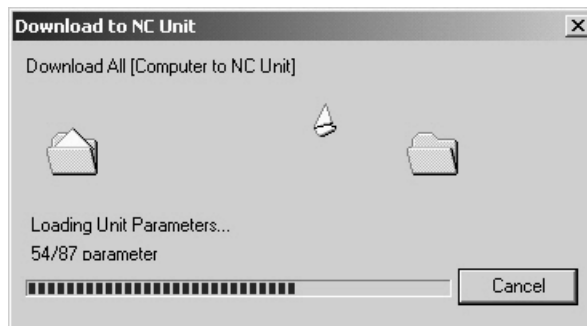

- If the communications between the Position Control Unit and Servo Drive are established after the download is completed, the following dialog box will be displayed to confirm whether to release the connection.

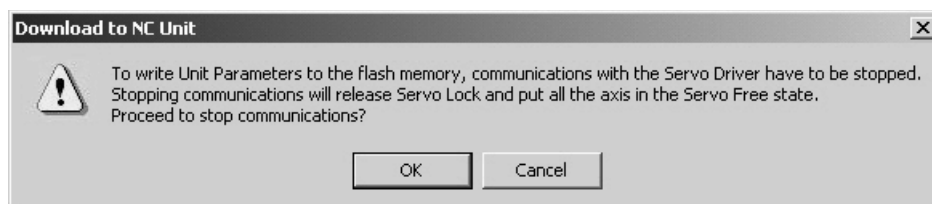

- Click the **OK** Button to release the connection. The following dialog box will be displayed to confirm whether to restart the Position Control Unit.

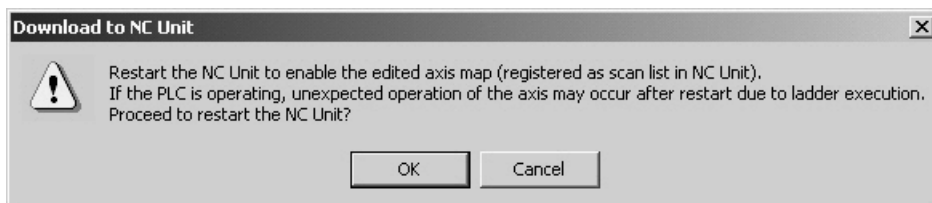

- Clicking the **OK** Button will restart the Position Control Unit to enable the registered scan list. After being restarted, Servo Parameters will be transferred to the Servo Drive.

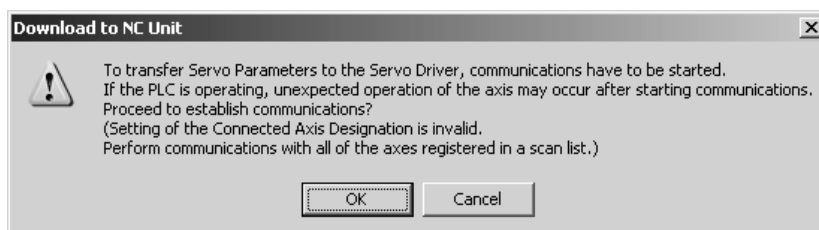

Note Servo Parameters of the axis registered in the Axis Map Setting Window as *Unknown Model* will not be transferred.

7. Click the **OK** Button.
If the Servo Drive models do not match at this point, the following confirmation message will be displayed.

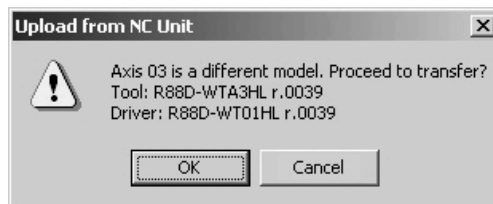

8. Click the **OK** Button to establish the connection and transfer Servo Parameters to the Servo Drive.
Clicking the **Cancel** Button will cancel transferring, however, the parameters that were transferred before the cancellation will already be transferred to the Servo Drive.

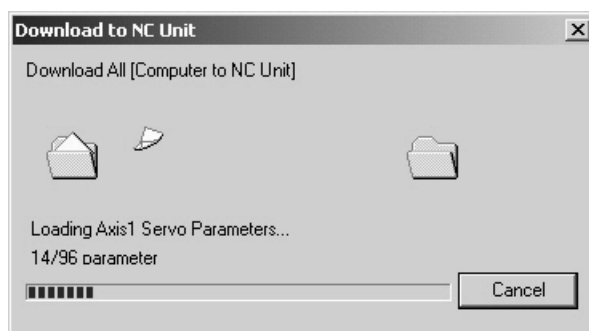

9. When the Download to NC Unit Dialog Box is closed, the download will be completed.

Note When the MECHATROLINK communications cannot be started, only Unit Parameters will be downloaded.

7-3-2 Downloading Unit Parameters

- 1,2,3... 1. Click the **Download** Button in the Edit Unit Parameter Window. The following dialog box will be displayed.
To write Unit Parameters to the flash memory after downloading, select the checkbox for writing to flash memory.

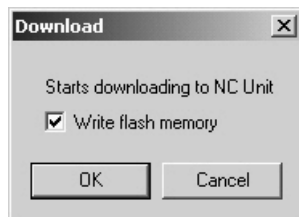

Caution After downloading Unit Parameters to the Position Control Unit, always backup the parameters in the flash memory. Otherwise, the parameter settings before the download will be enabled when the power is turned ON next time (i.e. the downloaded parameters will be lost and not be reflected), which may cause the machines to operate in an unexpected way.

2. Click the **OK** Button.
If the communications between the Position Control Unit and Servo Drive are established at this point, the following dialog box will be displayed to confirm whether to release the connection or not.

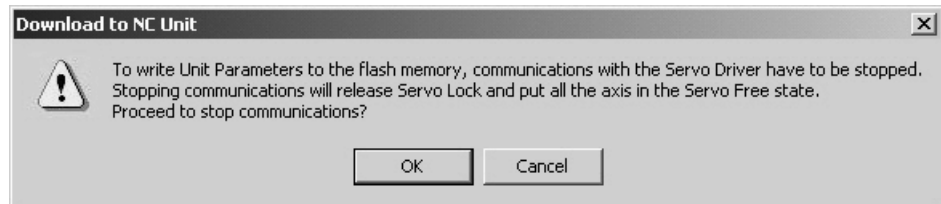

3. Click the **OK** Button to release the connection and start downloading Unit Parameters to the Position Control Unit.
Clicking the **Cancel** Button will cancel downloading, however, the parameters that were downloaded before the cancellation should be downloaded to the Position Control Unit.

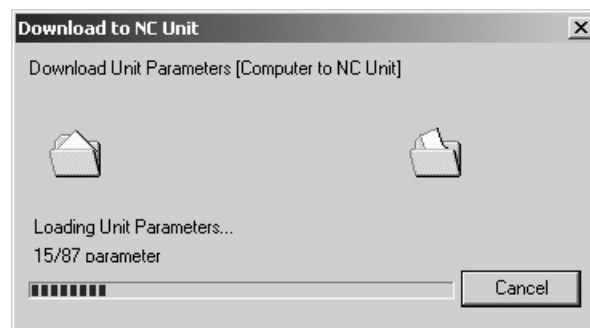

4. If the checkbox for writing to flash memory was selected a few steps before, the following dialog box will be displayed to confirm that the Position Control Unit will be restarted to enable the registered axis map after completion of the download.

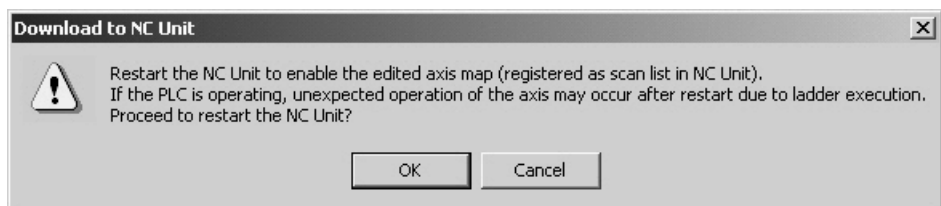

5. Click the **OK** Button to restart the Position Control Unit.
6. If the connection was released in step 2, the connection status can be restored (established in this case) here. To establish the connection, click the **OK** Button. Otherwise, click the **Cancel** Button.

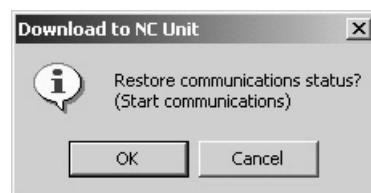

7. When the Download to NC Unit Dialog Box is closed, the download will be completed.

7-3-3 Downloading Servo Parameters

- 1,2,3... 1. Click the **Download** Button in the Edit Servo Parameter Window. The checkbox of Selected Parameters will be displayed. To download only the selected parameters, select the checkbox. If the checkbox is not selected here, all the Servo Parameters will be downloaded.

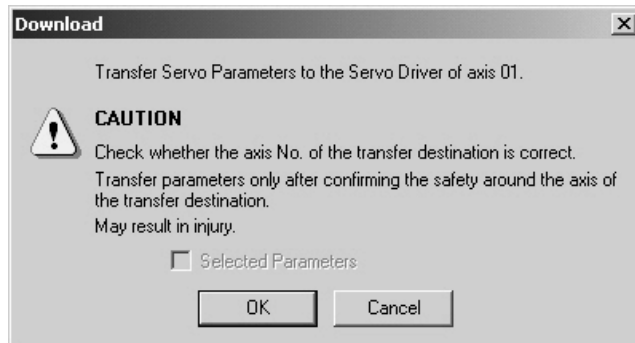

2. Click the **OK** Button. If the communications between the Position Control Unit and Servo Drive are not established at this point, the following dialog box will be displayed to confirm whether to establish the connection or not.

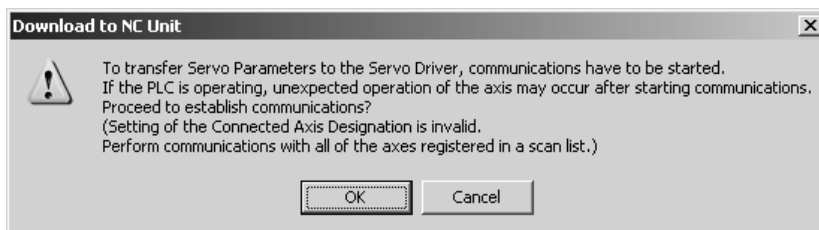

3. Click the **OK** Button to establish the connection and start downloading Servo Parameters to the Servo Drive.
 4. If the Servo Drive models do not match at this point, the following confirmation message will be displayed. To continue downloading, click the **OK** Button.

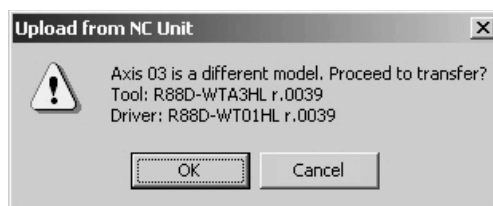

5. Clicking the **Cancel** Button will cancel downloading, however, the parameters that were downloaded before the cancellation should be downloaded to the Servo Drive.

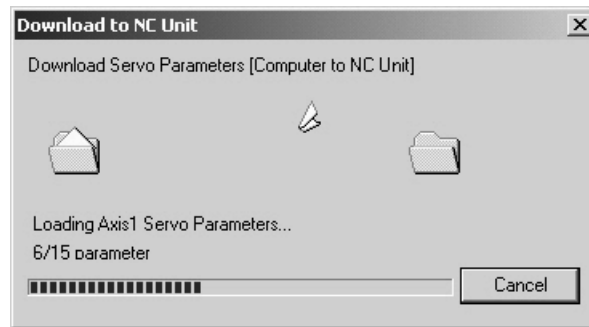

6. If the connection was established at Step 2, the connection status can be restored (released in this case) here. To release the connection, click the **OK** Button. Otherwise, click the **Cancel** Button.



7. When the Download to NC Unit Dialog Box is closed, the download will be completed.

Note When the MECHATROLINK communications cannot be started, Servo Parameters cannot be downloaded. Start the MECHATROLINK communications first and download Servo Parameters.

7-4 Uploading Data

The object of uploading varies depending on the operation method.

Batch Uploading

Uploads Unit Parameters and Servo Parameters of all the Servo Drives registered in the scan list in the Position Control Unit.

Uploading Unit Parameters

Uploads Unit Parameters.

Uploading Servo Parameters

Uploads Servo Parameters.

Note Comments are not saved in the Unit, so they cannot be uploaded.

Note Before starting MECHATROLINK communications, make sure that the PLC is in the PROGRAM Mode. Otherwise, the axis may start moving suddenly due to the ladder execution.

Before disconnecting MECHATROLINK communications, make sure that the axis is not operating. Disconnecting MECHATROLINK communications will put the operating axis in the Servo Free state.

7-4-1 Batch Uploading

- 1,2,3... 1. In the Axis Map Setting Window, select **Online - Upload from NC Unit**, click  in the toolbar, or right-click the Position Control Unit and select **Upload from NC Unit** from the pop-up menu. The following dialog box will be displayed.

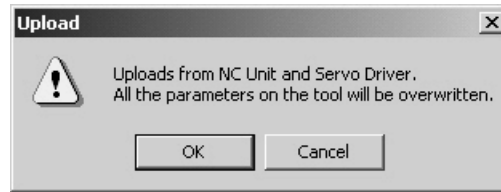

2. Click the **OK** Button.
Cancels all the parameters being edited and close the Edit Windows.

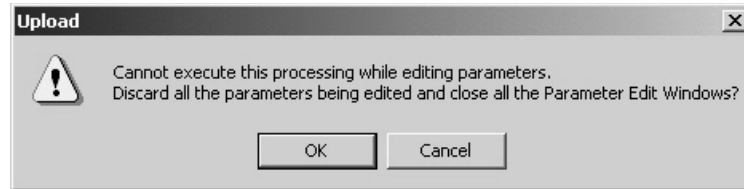

3. Click the **OK** Button. Uploading Unit Parameters from the Position Control Unit will start. Clicking the **Cancel** Button will cancel the upload.

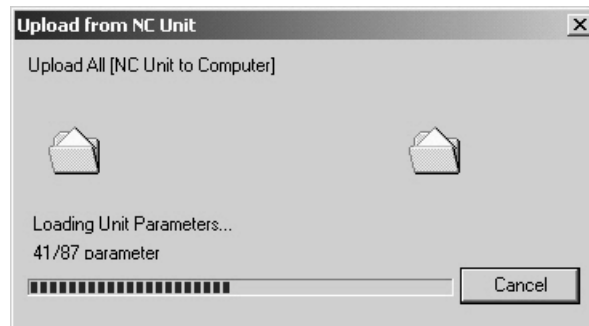

4. If the connection between the Position Control Unit and Servo Drive is not established at this point, the following dialog box will be displayed.

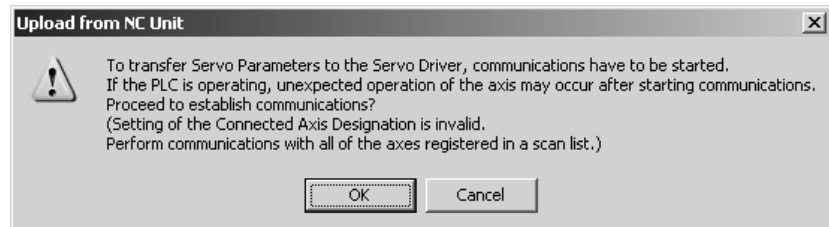

5. Click the **OK** Button to establish the connection and start uploading Servo Parameters from the Servo Drive.
Clicking the **Cancel** Button during uploading will cancel the upload.

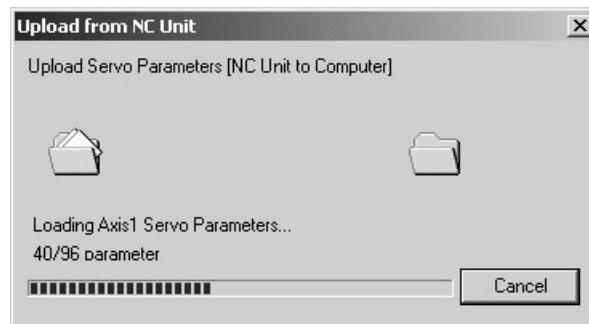

If the connection cannot be established at this point, the following dialog box will be displayed. Click the **OK** Button and the axes registered in the Position Control Unit will be displayed as Unknown Model.

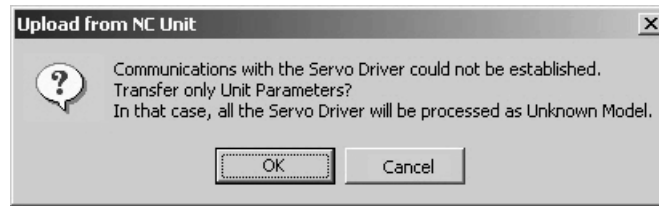

6. If the connection was established at Step 4, the connection status can be restored (released in this case) here. To release the connection, click the **OK** Button. To leave the connection established, click the **Cancel** Button.

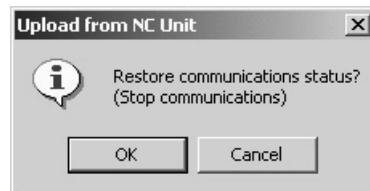

7. When the Upload from NC Unit Dialog Box is closed, the upload will be completed.

Note Batch uploading will overwrite the parameters on the computer, which means that the parameters being edited will also be erased. When the MECHATROLINK communications cannot be started, only Unit Parameters can be uploaded.

7-4-2 Uploading Unit Parameters

- 1,2,3... 1. Click the **Upload** Button in the Edit Unit Parameter Window.

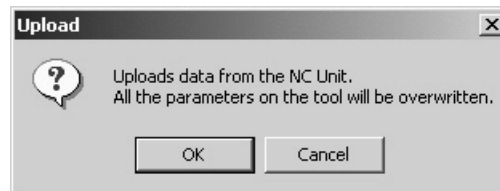

2. Clicking the **OK** Button will start uploading Unit Parameters from the Position Control Unit. Clicking the **Cancel** Button will cancel uploading.

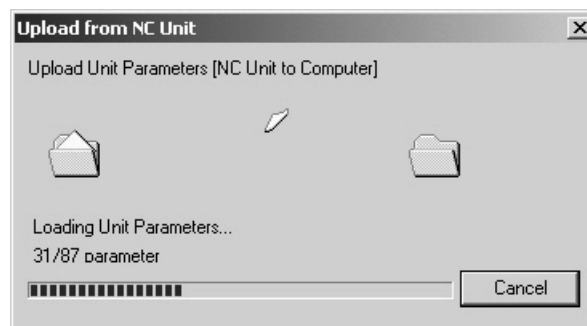

3. When the Upload from NC Unit Dialog Box is closed, the upload will be completed.

Note When the axis map on the computer is different from the scan list in the Position Control Unit, Unit Parameters will not be uploaded. Execute batch upload instead.

7-4-3 Uploading Servo Parameters

- 1,2,3... 1. Click the **Upload** Button in the Edit Servo Parameter Window. The following dialog box will be displayed.



2. Click the **OK** Button.
If the connection between the Position Control Unit and Servo Drive are not established at this point, the following dialog box will be displayed to confirm whether to establish the connection or not.

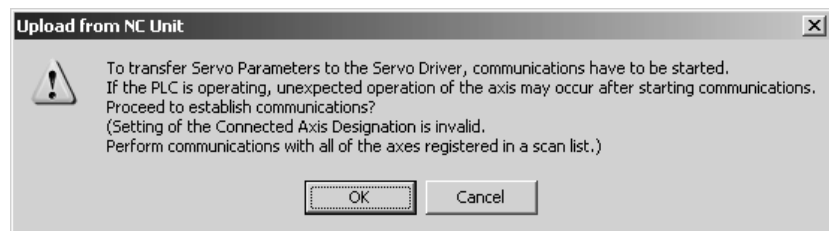

3. Click the **OK** Button to establish communications and start uploading Servo Parameters from the Servo Drive.
4. If the Servo Drive models do not match, the following confirmation message will be displayed. To continue uploading, click the **OK** Button.

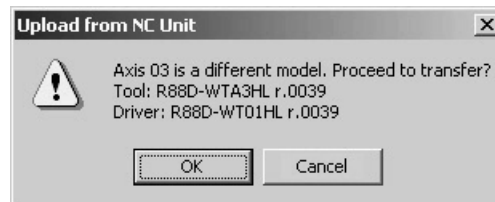

5. Click the **Cancel** Button to cancel uploading.

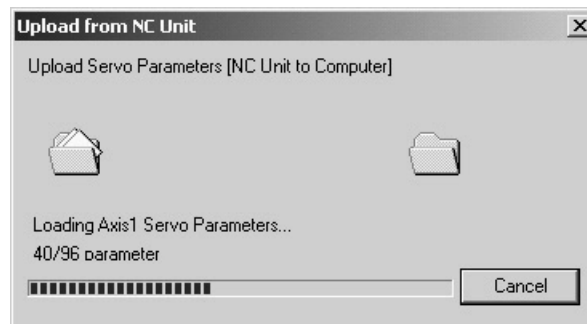

6. If the connection was established in step 2, the connection status can be restored (released in this case) here. To release the connection, click the **OK** Button. To leave the connection established, click the **Cancel** Button.



- When the Upload from NC Unit Dialog Box is closed, the upload will be completed.

Note When the MECHATROLINK communications cannot be started, Servo Parameters cannot be uploaded. Start the MECHATROLINK communications first and upload Servo Parameters.

7-5 Comparing Data

The objects of comparing varies depending on the operation method.

Batch Comparing

Compares the data on the CX-Motion-NCF with the Unit Parameters and Servo Parameters of the Servo Drives registered in the scan list in the Position Control Unit.

Comparing Unit Parameters

Compares the data on the CX-Motion-NCF with the Unit Parameters in the Position Control Unit.

Comparing Servo Parameters

Compares the data on the CX-Motion-NCF with the Servo Parameters in the Servo Drive.

Note Before starting MECHATROLINK communications, make sure that the PLC is in the PROGRAM Mode. Otherwise, the axis may start moving suddenly due to the ladder execution.
Before disconnecting MECHATROLINK communications, make sure that the axis is not operating. Disconnecting MECHATROLINK communications will put the operating axis in the Servo Free state.

7-5-1 Batch Comparing

- 1,2,3...** In the Axis Map Setting Window, select **Online - Compare**, click  in the toolbar, or right-click the Position Control Unit and select **Compare** from the pop-up menu. The following dialog box will be displayed.

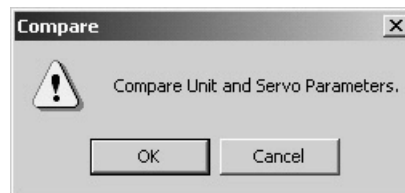

- Click the **OK** Button. All the parameters being edited will be discarded and the Edit Windows will be closed.

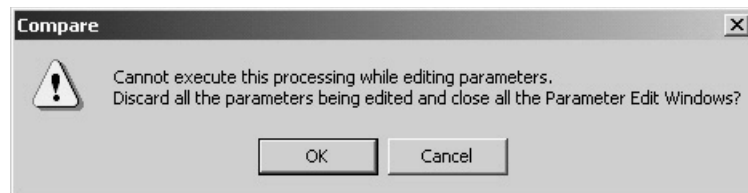

- Click the **OK** Button. Uploading Unit Parameters from the Position Control Unit will start. Clicking the **Cancel** Button will cancel the upload.

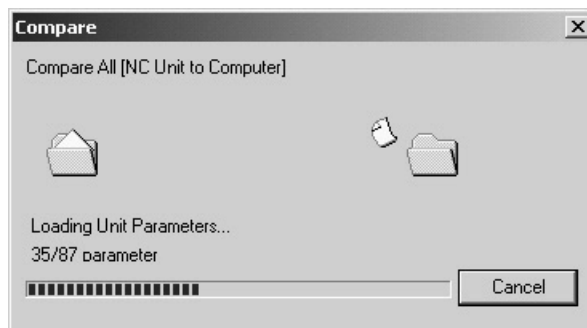

- If the communications between the Position Control Unit and Servo Drive are not established at this point, the following dialog box will be displayed to confirm whether to establish the connection or not.

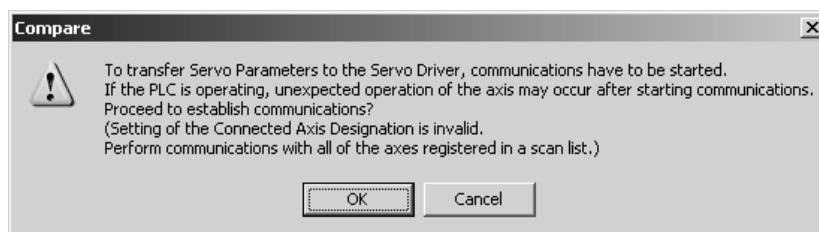

- Click the **OK** Button to establish the connection and start uploading Servo Parameters from the Servo Drive. Clicking the **Cancel** Button will cancel the upload.



If the connection cannot be established at this point, the following dialog box will be displayed. Click the **OK** Button and the axes registered in the Position Control Unit will be displayed as Unknown Model in the Axis Map Setting Window.

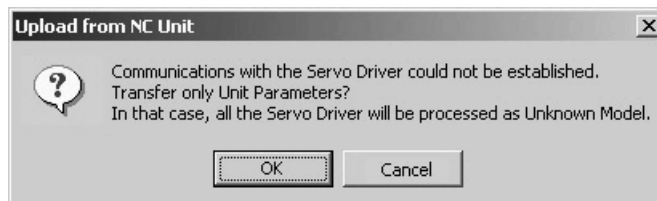

- If the connection was established in step 4, the connection status can be restored (released in this case) here. To release the connection, click the **OK** Button. To leave the connection established, click the **Cancel** Button.



- After completion of uploading Unit and Servo Parameters, they are compared with the parameters on the personal computer. If they match, the following dialog box will be displayed.

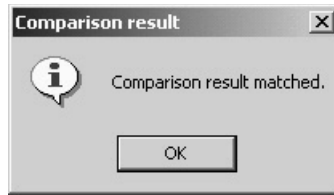

If there is any mismatch in the comparison, the following window will be displayed to show the parameters that did not match.

Type	Parameter name	Setting on Computer	Setting on Unit
Unit No.02 New NC1	Axis Operating Output Memory Area	D0	C100
Unit No.02 New NC1	Axis Operating Input Memory Area	D1000	C101000
Unit No.02 New NC1	Axis configuration Axis 2	Servo Driver	Not used
Unit No.02 New NC1	Axis configuration Axis 16	Servo Driver	Not used
Unit No.02 New NC1	Transfer cycle	2 [ms]	0.5 [ms]
Unit No.02 New NC1	Axis 1: Encoder Type	Incremental Encoder	Absolute Encoder
Axis 01 New Driver 01(R88D-WN01L...	Pr102 Position loop gain	400	200
Axis 01 New Driver 01(R88D-WN01L...	Pr50A Input signal selection 1	1881H	8881H
Axis 01 New Driver 01(R88D-WN01L...	Pr50A.3 POT (forward drive prohibite...	1:Allocated to CN1, ...	8:Always disabled.
Axis 01 New Driver 01(R88D-WN01L...	Pr50B Input signal selection 2	8882H	8888H
Axis 01 New Driver 01(R88D-WN01L...	Pr50B.0 NOT (reverse drive prohibite...	2:Allocated to CN1, ...	8:Always disabled.

Note When the MECHATROLINK communications cannot be started, batch comparing cannot be executed. Start the MECHATROLINK communications first and execute batch comparing.

7-5-2 Comparing Unit Parameters

- 1,2,3... 1. Click the **Compare** Button in the Edit Unit Parameter Window. The following dialog box will be displayed.

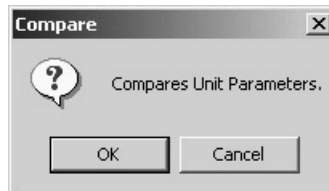

2. Click the **OK** Button to start comparing. Uploading Unit Parameters will start at first.
Clicking the **Cancel** Button during comparing will cancel comparing.

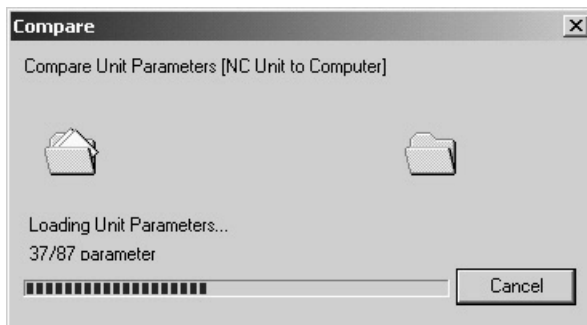

3. After completion of uploading, the following dialog box will be displayed if Unit Parameters have no mismatch.

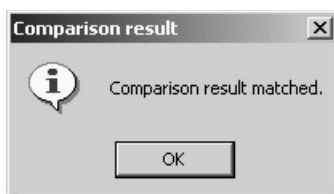

If there is any mismatch in the comparison, the following window will be displayed to show the parameters that did not match.

Type	Parameter name	Setting on Computer	Setting on Unit
Unit No.02 New NC1	Axis Operating Output Memory Area	D0	C100
Unit No.02 New NC1	Axis Operating Input Memory Area	D1000	C101000
Unit No.02 New NC1	Axis configuration Axis 2	Servo Driver	Not used
Unit No.02 New NC1	Axis configuration Axis 16	Servo Driver	Not used
Unit No.02 New NC1	Transfer cycle	2 [ms]	0.5 [ms]
Unit No.02 New NC1	Axis 1: Encoder Type	Incremental Encoder	Absolute Encoder

7-5-3 Comparing Servo Parameters

- 1,2,3... 1. Click the **Compare** Button in the Edit Servo Parameter Window. The following dialog box will be displayed.

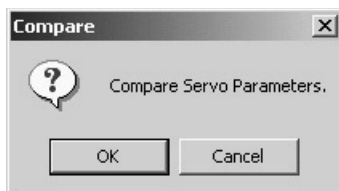

2. Click the **OK** Button.

If the communications between the Position Control Unit and Servo Drive are not established at this point, the following dialog box will be displayed to confirm whether to establish the connection or not.

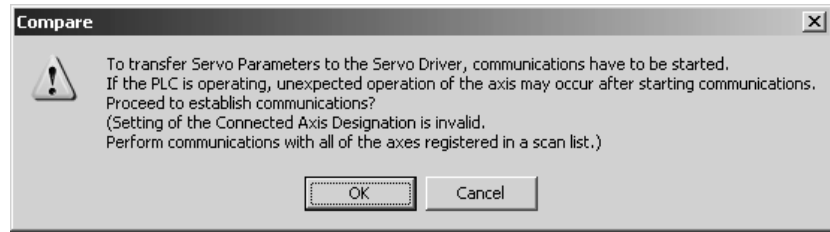

3. Click the **OK** Button to establish the communications and start uploading Servo Parameters.
4. If the Servo Drive models do not match, the following confirmation message will be displayed. To continue uploading, click the **OK** Button.

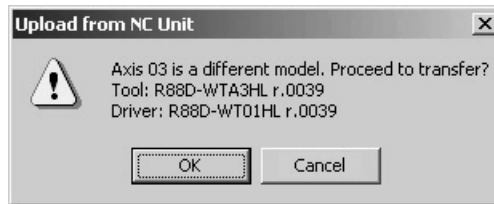

5. Clicking the **Cancel** Button during comparing will cancel comparing.

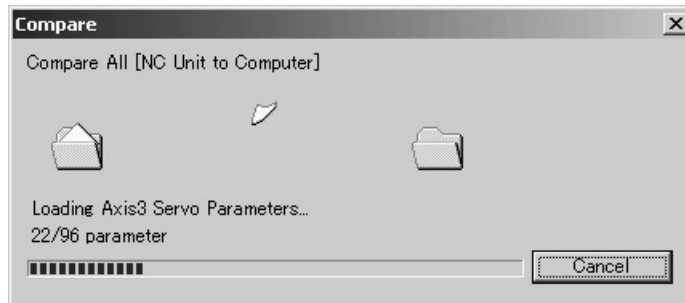

6. If the connection was established in step 2, the connection status can be restored (released in this case) here. To release the connection, click the **OK** Button. To leave the connection established, click the **Cancel** Button.

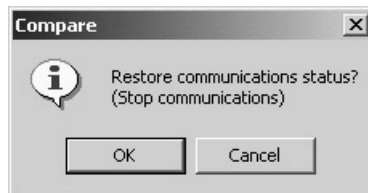

7. After completion of comparing, the following dialog box will be displayed if Servo Parameters have no mismatch.

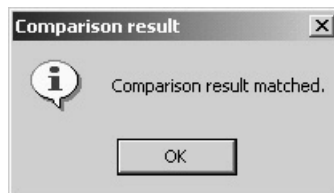

If there is any mismatch in the comparison, the following window will be displayed to show the parameters that did not match.

Type	Parameter name	Setting on Computer	Setting on Unit
Axis 01 New Driver 01(R88D-WN01L:...	Pr102 Position loop gain	400	200
Axis 01 New Driver 01(R88D-WN01L:...	Pr50A Input signal selection 1	1881H	8881H
Axis 01 New Driver 01(R88D-WN01L:...	Pr50A.3 PDI (forward drive prohibite...	1:Allocated to CN1, ...	8:Always disabled.
Axis 01 New Driver 01(R88D-WN01L:...	Pr50B Input signal selection 2	8882H	8888H
Axis 01 New Driver 01(R88D-WN01L:...	Pr50B.0 NDT (reverse drive prohibite...	2:Allocated to CN1, ...	8:Always disabled.

Note When the MECHATROLINK communications cannot be started, Servo Parameters cannot be compared. Start the communications first and compare Servo Parameters.

7-6 Writing to Flash Memory

Unit Parameters downloaded to the Position Control Unit will be lost when the power is turned OFF. Therefore, they have to be written to the flash memory to keep them after powering OFF.

If Unit Parameters were not written to the flash memory during downloading process, make sure to write them to the flash memory.

Writing to Flash Memory

Caution After downloading Unit Parameters to the Position Control Unit, always backup the parameters in the flash memory. Otherwise, the parameter settings before the download will be enabled when the power is turned ON next time (i.e. the downloaded parameters will be lost and not be reflected), which may cause the machines to operate in an unexpected way.

- 1,2,3... 1. Select **Online - Write Flash Memory**, or click  in the toolbar in the Axis Map Setting Window. The following dialog box will be displayed.



2. Click the **OK** Button.
If the communications between the Position Control Unit and Servo Drive are established at this point, the following dialog box will be displayed to confirm whether to release the connection or not.

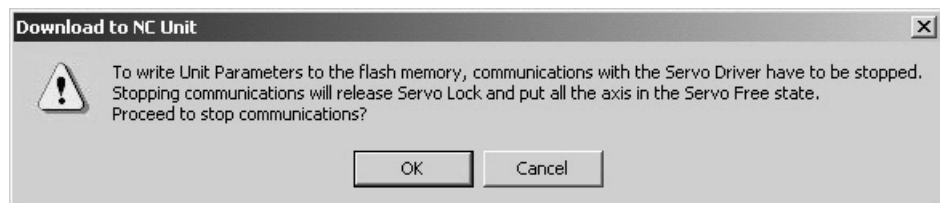

3. Click the **OK** Button.

The following dialog box will be displayed to confirm whether to restart the Position Control Unit or not. To enable the Unit Parameters written to the flash memory, the Position Control Unit must be restarted.

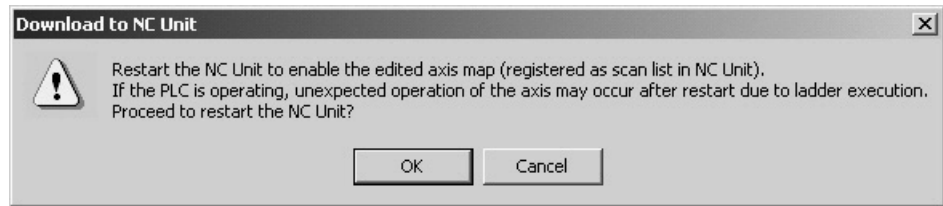

4. If the connection was released in step 2, the connection status can be restored (established in this case) here. To establish the connection, click the **OK** Button. To leave the connection released, click the **Cancel** Button.



5. The writing operation is completed when the Write to flash memory window is no longer displayed.

Note If an error occurs in writing to the flash memory, the Unit Parameters may not be written to the flash memory successfully. In this case, write the Unit Parameters to the flash memory again after resetting the error.

SECTION 8

Monitor

The Position Control Unit's communications status, error status, and axis's present position and status are displayed in the Monitor Windows.

Note Make sure that the computer and PLC are connected with the connection cable and the communications between them are established before starting monitoring operations.

8-1	Unit Monitor	70
8-2	Axis Monitor	73

8-1 Unit Monitor

In Unit Monitor, communications status, Position Control Unit errors, and present position of each axis are monitored.

Starting Unit Monitor (Unit Monitor Common Items, Unit Status Monitor, Present Position Monitor)

- 1,2,3...
- In the Axis Map Setting Window, select **Online - Unit Monitor**, or click  in the toolbar, or right-click the Position Control Unit and select **Unit Monitor** from the pop-up menu.
If the connection to the Position Control Unit is not established at this point, the following dialog box will be displayed.

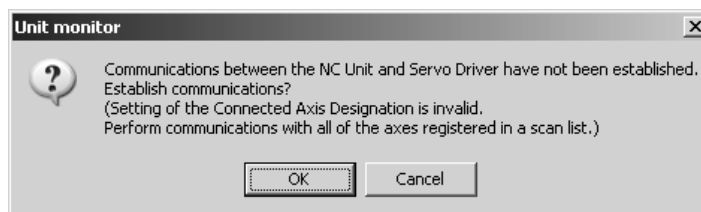

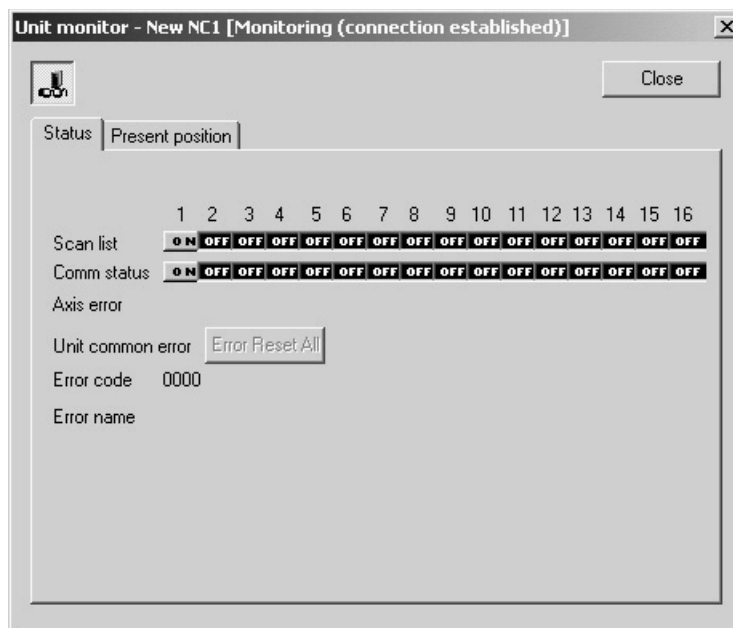

- Click the **OK** Button to establish the connection (i.e., start communications).



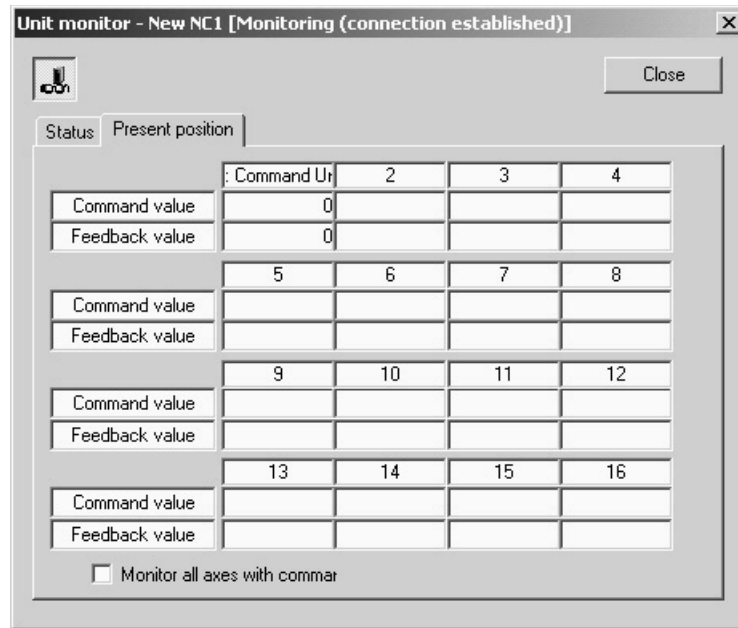

- Click  to stop monitoring. Clicking the same button again will restart monitoring.

- Click the **Present Position** Tab to display the Present Position Monitor Tab Page.





- Click the **Close** Button or  at the right top corner to end monitoring the Position Control Unit.

Unit Monitor Common Items

Name	Explanation	
Title Bar	Shows the status of monitoring and communications between Position Control Unit and Servo Drive. <ul style="list-style-type: none"> • Stop: Monitoring stopped. • Monitoring (Connection Released): Monitoring in progress, however, communications between Position Control Unit and Servo Drive have not been started. Therefore, information about axes is not displayed. • Monitoring (Connection Established): Entire information is displayed. 	
Monitor Start/Stop Button		Starts monitoring. If communications between Position Control Unit and Servo Drive have not been started, the connection will be established first.
		Stops monitoring.
Close Button	Closes the monitor window.	

Unit Status Monitor

Item	Explanation
Scan list	Indicates whether the axes are registered in the scan list or not.
Comm (Communications) status	Indicates whether the communications with the axis 1 to 16 are established or not.
Axis error	Displays the axis where an error or warning has occurred. With errors:  With warnings: 

Item		Explanation
Unit common error	Error reset all	Pressing this button will reset all the error occurring in the Position Control Unit and Servo Drives.
	Error code	Displays the error code of the error occurring in the Position Control Unit. When there is no error, the code "0000" is displayed.
	Error name	Displays the name of the error occurring in the Position Control Unit.

1,2,3...

1. When an error occurs in the Position Control Unit, the following window will be displayed.

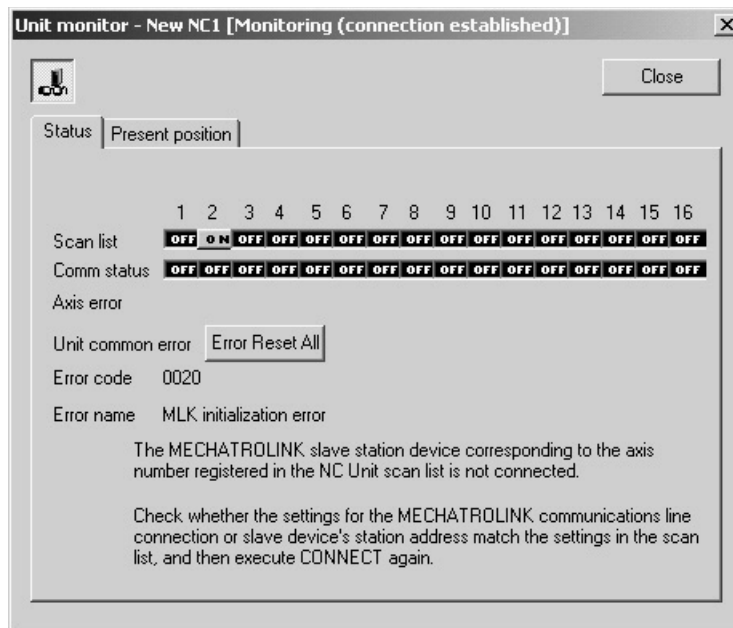

2. When an error or warning occurs on an axis, the following window will be displayed.

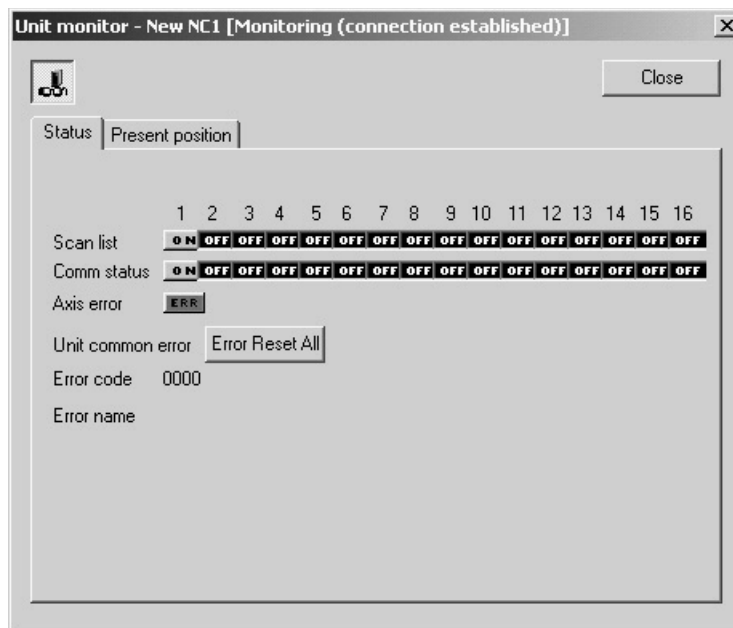

Present Position Monitor

Item	Explanation
Command value	Displays the command value of each axis.
Feedback value	Displays the feedback value of each axis.
Monitor all axes with command unit	If selected (i.e., checked), all the axes will be monitored using command unit. Pulse rate and unit are set in Axis Monitor.

Note When performing Unit Monitor, set the Input Memory Area of the Axis Operating Memory Area Designation in the Edit Unit Parameter Window and transfer the setting to the Position Control Unit. If it is not set, the data in the Unit is monitored directly, which makes the response slower.

8-2 Axis Monitor

In Axis Monitor, present values, status, external I/O, and error information of axes are monitored.

Starting Axis Monitor (Axis Monitor Common Items, Basic Monitor, Status Monitor, Present Value Monitor)

1,2,3...

1. In the Axis Map Setting Window, select **Online - Axis Monitor**, click  in the toolbar, or right-click the Position Control Unit or Servo Drive and select **Axis Monitor**. If the communications between the Position Control Unit and Servo Drive have not been established at this point, the following dialog box will be displayed.

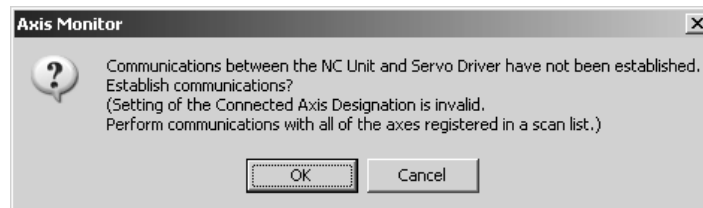

- Click the **OK** Button to start communications (i.e., establish connection).

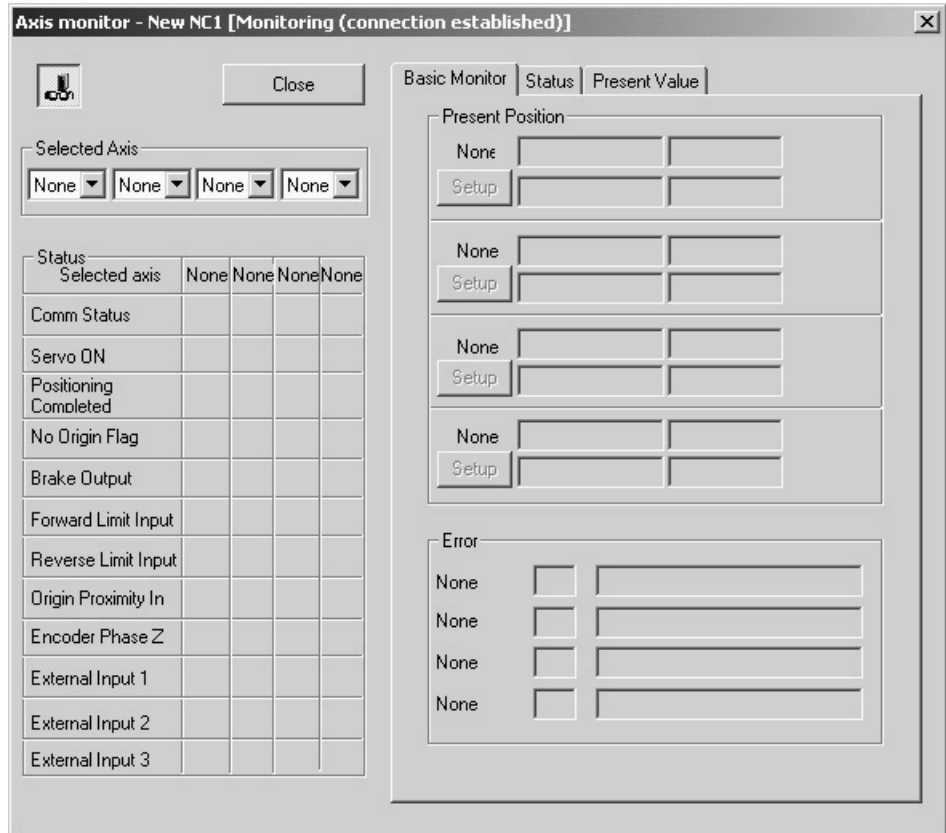

- In the drop-down list of Monitored Axes, the axes registered in the scan list of the Position Control Unit will be displayed. Select axes to be monitored.

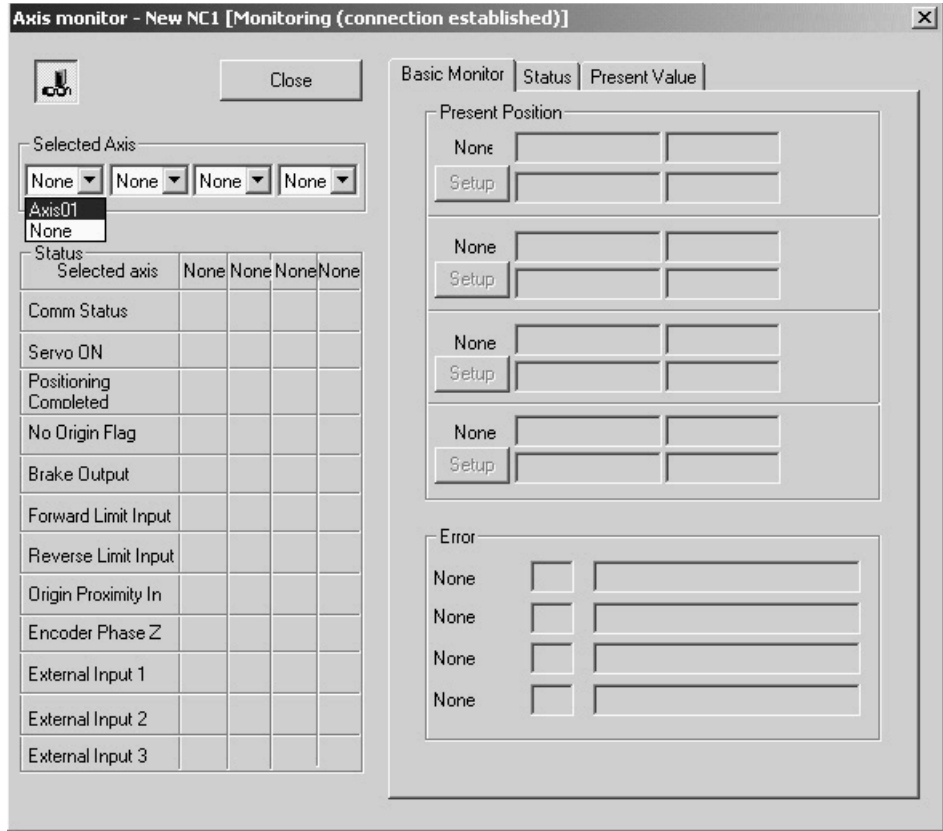

- Click the **Basic Monitor** Tab to display present values and errors.

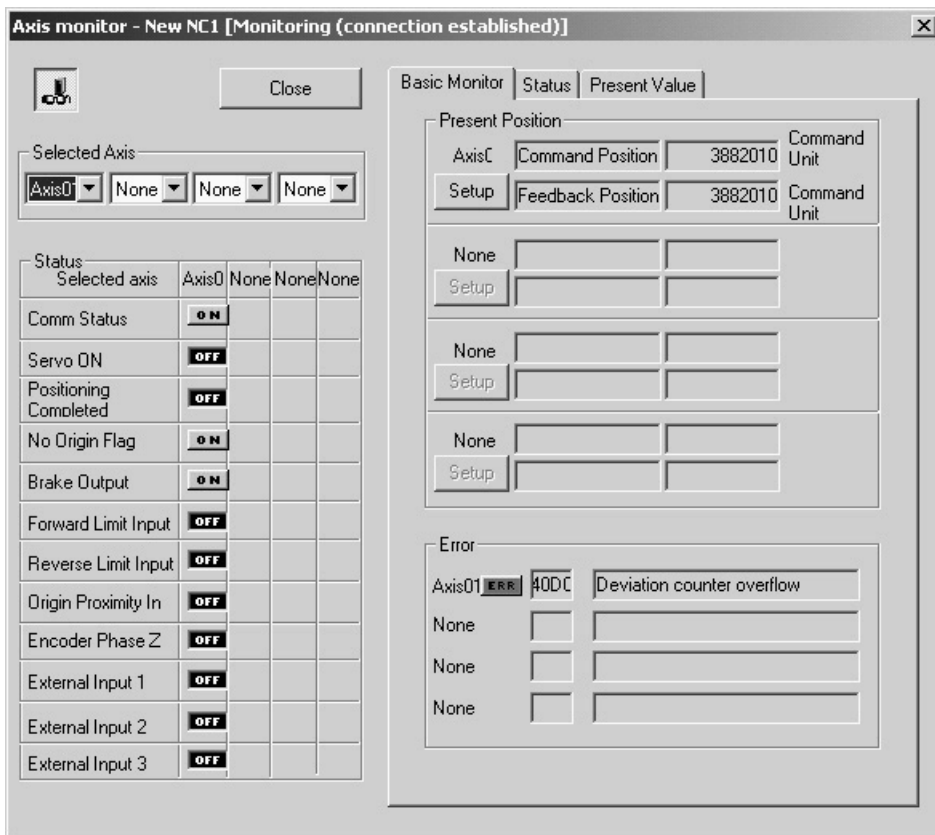

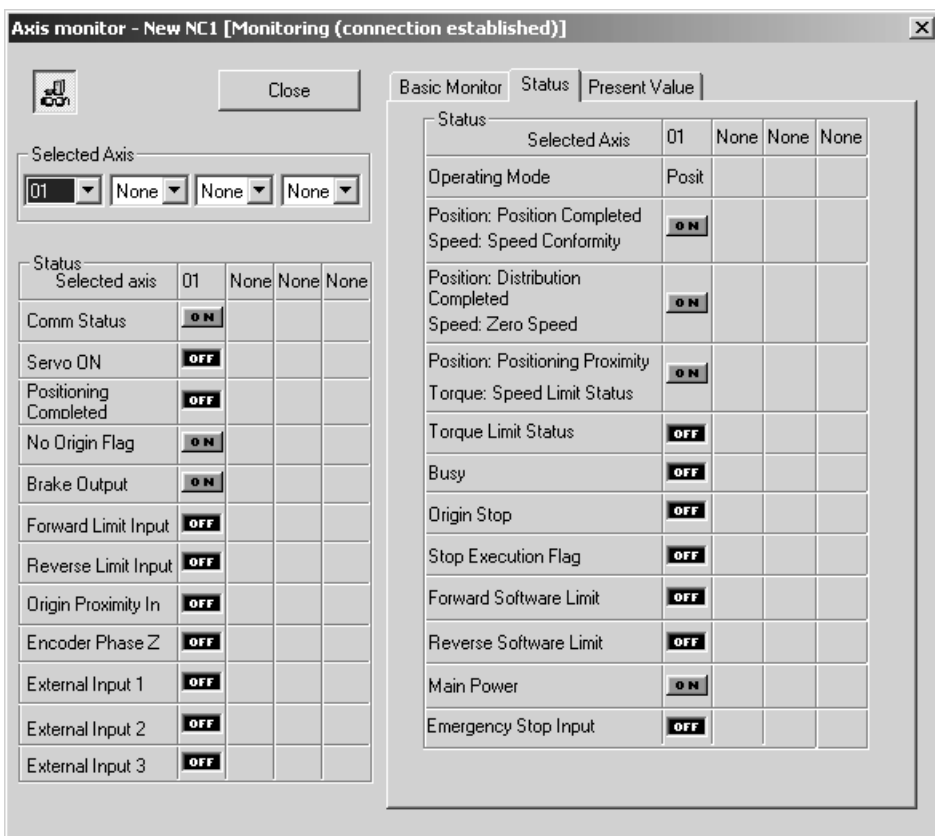

- Click the **Status** Tab to display all the status information.



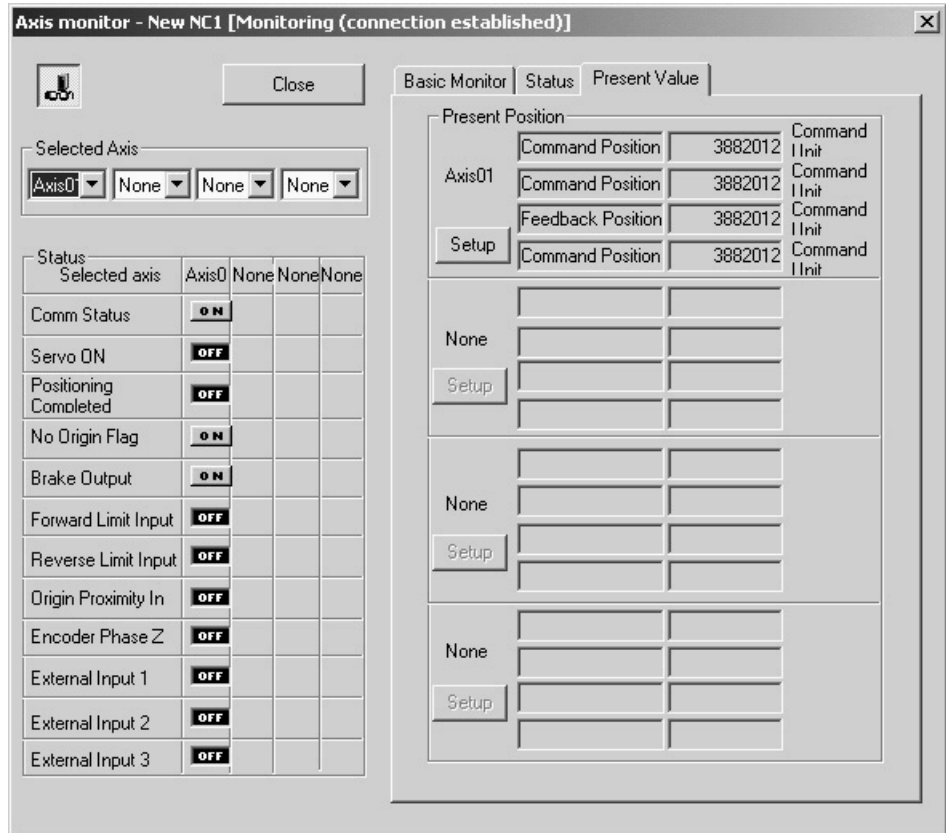

- Click the **Present Value** Tab to display various present values.



- Click  to stop monitoring. Clicking the same button again will resume monitoring.
- Click the **Close** Button or  at the right top corner of the window to close the Axis Monitor Window.

Note When performing Unit Monitor, set the Input Memory Area of the Axis Operating Memory Area Designation in the Edit Unit Parameter Window and transfer the setting to the Position Control Unit. If it is not set, the data in the Unit is monitored directly, which makes the response slower.

Axis Monitor Common Items

Name	Explanation	
Title Bar	Shows the status of monitoring and communications between Position Control Unit and Servo Drive. <ul style="list-style-type: none"> • Stop: Monitoring stopped. • Monitoring (Connection Released): Monitoring in progress, however, communications between Position Control Unit and Servo Drive have not been started. Therefore, information about axes is not displayed. • Monitoring (Connection Established): Entire information is displayed. 	
Monitor Start/Stop Button		Starts monitoring. If communications between Position Control Unit and Servo Drive have not been started, the connection will be established first.
		Stops monitoring.
Close Button	Closes the monitor window.	

Selected Axis



Name	Explanation
Selected Axis	Specifies axes to be monitored. The axes registered in the scan list of the Position Control Unit are displayed in the drop-down list.

Status

Name		Explanation
Status	Communications Status	Status of each signal is displayed.
	SERVO ON	
	NC Unit Positioning Completed	
	No Origin Flag	
	Brake Output	
	Forward Rotation Limit Input	
	Reverse Rotation Limit Input	
	Origin Proximity Input	
	Encoder Phase Z Input	
	External Latch Signal 1 Input	
	External Latch Signal 2 Input	
	External Latch Signal 3 Input	

Basic Monitor

Name		Explanation
Present Value	Present Value Display	Present position, speed, etc. are displayed.
	Monitor Setup Button	Press this button to change displayed contents, unit, and pulse rate. Unit and pulse rate can be set only for the axes registered in the Axis Map Setting Window.

Name		Explanation
Error	Error	Status of errors is displayed. With errors:  With warnings: 
	Error code	When an error occurs, the error code will be displayed. When there is no error, the code "0000" will be displayed. Click the error code to display help.
	Error Name	When an error occurs, the error name will be displayed. Click the error name to display help.

1,2,3...

1. Click the **Setup** Button to display the Monitor Setup Window.
2. Specify the type of monitored present value, unit, and pulse rate.
3. Once setup is completed, click the **OK** Button to save the settings. To discard the settings, click the **Cancel** Button.

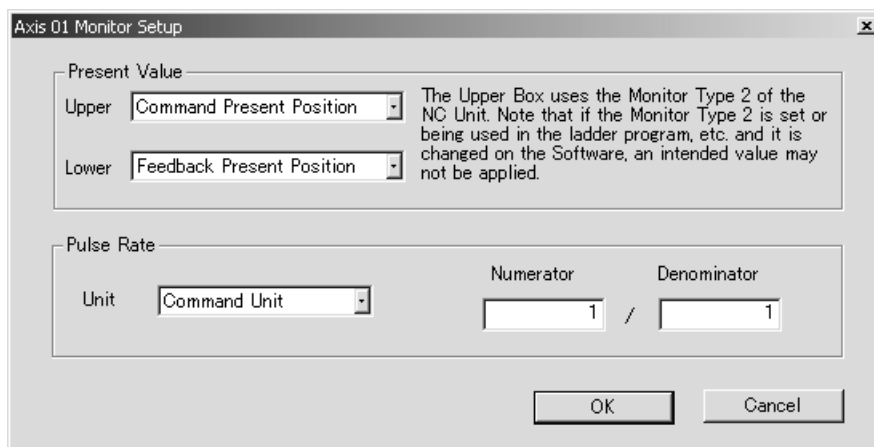

Name		Explanation
Present Value	Upper Box	Specify the item to be displayed in the upper box. <ul style="list-style-type: none"> • Command Present Position • Position Deviation • Feedback Present Position • Latch Position • Target Position • Feedback Speed • Command Speed • Target Speed • Torque Command
	Lower Box	Specify the item to be displayed in the lower box. <ul style="list-style-type: none"> • Command Present Position • Feedback Present Position

Name		Explanation
Pulse Rate	Unit	Specify the unit used for displaying values. <ul style="list-style-type: none"> • command unit • pulse • inch • mm • degree When command unit is set, setting numerator and denominator of the pulse rate is invalid.
	Numerator	Set the numerator of the pulse rate. The setting range is from 1 to 4294967294.
	Denominator	Set the denominator of the pulse rate. The setting range is from 1 to 4294967294.

Note Monitoring the item specified in the upper box uses the Monitor Type 2 of the Position Control Unit's Expanded Monitoring function. If the Monitor Type 2 is set and being used in the ladder program, etc., do not set it on the Support Software.

Status Monitor

Name		Explanation
Servo Status	Operating Mode	Displays the operating mode (Position, Speed, Torque).
	Position: Positioning Completed Flag	Displays the status of each flag. The meanings of the flags change depending on the operating mode.
	Speed: Speed Conformity Flag	
	Position: Distribution Completed	
	Speed: Zero Speed Flag	
	Position: Positioning Proximity Flag	Displays the status of each flag. Note The Emergency Stop Input Flag is displayed for Position Control Units with unit version 2.0 or higher.
	Torque: Speed Limit Status Flag	
	Torque Limit	
	Busy Flag	
	Origin Stop Flag	
	Stop Execution Flag	
	Forward Software Limit	
	Reverse Software Limit	
Main Power Supply ON		
Emergency Stop Input (See note.)		

Present Value Monitor

Name		Explanation
Present Value	Present Value Display	Displays present positions, speed, etc. The Monitor Type 1 and 2 of the upper 2 boxes can be changed using the Monitor Setup Button. Feedback Present Position and Command Present Position of the lower 2 boxes cannot be changed.
	Monitor Setup Button	Press this button to change displayed contents, unit, and pulse rate. Unit and pulse rate can be set only for the axes registered in the Axis Map Setting Window.

- 1,2,3...**
1. Click the **Setup** Button to display the Monitor Setup Window.
 2. Specify the type of monitored present value, unit, and pulse rate.

- Once setup is completed, click the **OK** Button to save the settings. To discard the settings, click the **Cancel** Button.

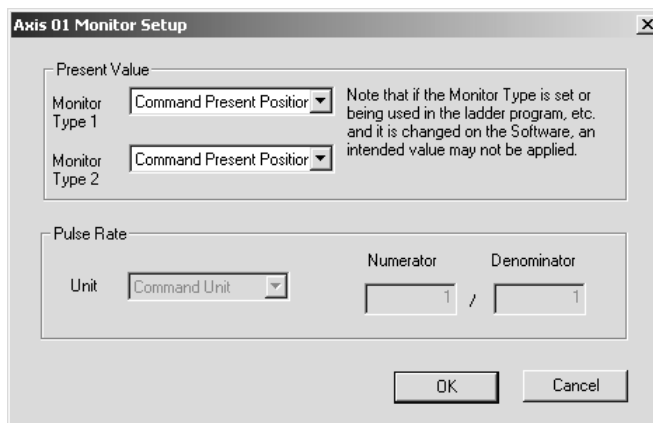

Name		Explanation
Present Value	Monitor Type 1	Specify the item to be displayed in the top box. <ul style="list-style-type: none"> • Command Present Position • Position Deviation • Feedback Present Position • Latch Position • Target Position • Feedback Speed • Command Speed • Target Speed • Torque Command
	Monitor Type 2	Specify the item to be displayed in the 2nd top box. The items to be selected are the same as for the Monitor Type 1.
Pulse Rate	Unit	Specify the unit used for displaying values. <ul style="list-style-type: none"> • command unit • pulse • inch • mm • degree When command unit is set, setting numerator and denominator of the pulse rate is invalid.
	Numerator	Set the numerator of the pulse rate. The setting range is from 1 to 4294967294.
	Denominator	Set the denominator of the pulse rate. The setting range is from 1 to 4294967294.

Note If the Monitor Type 1 and 2 of the Position Control Unit's Expanded Monitoring function are used in the ladder program, etc., do not set them on the Support Software.

SECTION 9

Test Run Operation

This section describes the test run operations for each axis.

9-1 Test Run 84

9-1 Test Run

The following operations are possible in Test Run.

- Establishing/releasing connection
- Locking/unlocking the Servo for each axis
- JOG operation execution

Displaying Test Run Window

Note The Test Run Window can be opened only when connected online in the CX-Motion-NCF Basic Window. If you are not connected online, connect online in the CX-Motion-NCF Basic Window first and then start the Test Run.

- 1,2,3...**
1. Select **Online - Test Run** in the Axis Map Setting Window. The warning dialog box shown below will be displayed. Read the contents of the warning carefully. Click the **OK** Button only after confirming safety.

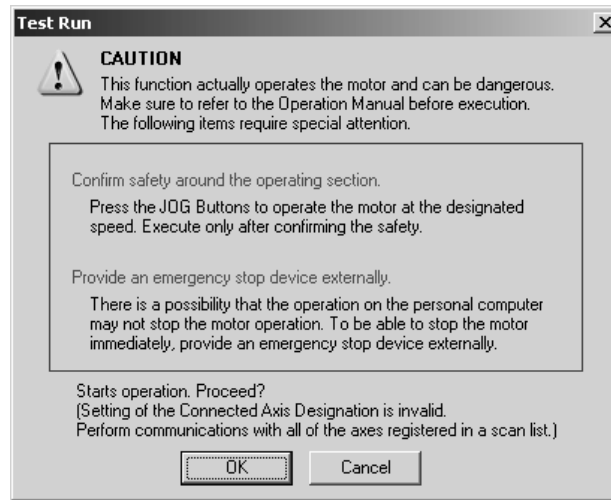

2. The Test Run Window will be displayed.

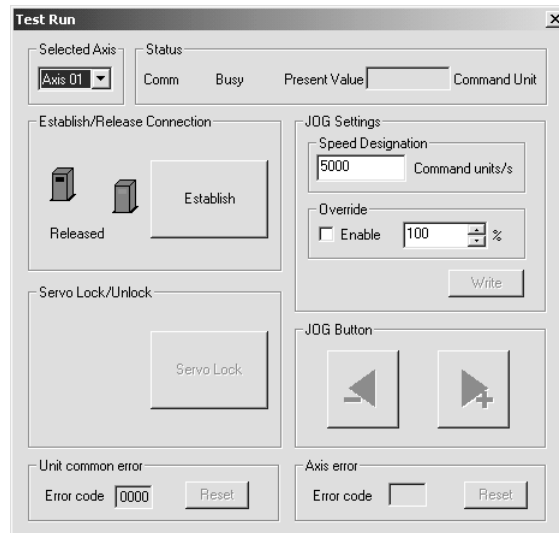

Quitting the Test Run

Click the **Close** Button at the right top corner of the Test Run Window. Closing the window will not change either the Servo lock status or the connection status.



JOG Operation Execution

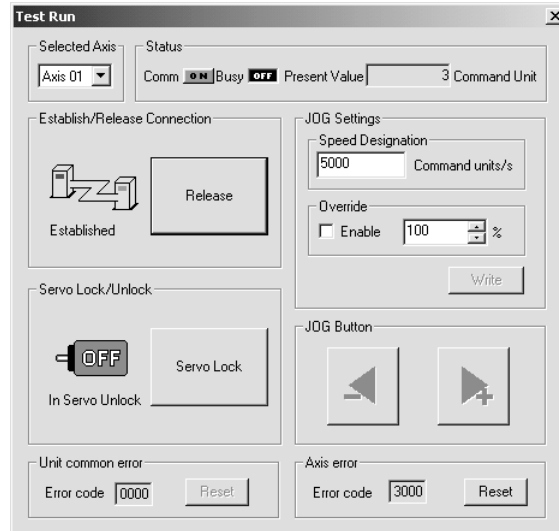

- 1,2,3...
1. Select the axis to jog in the Test Run Window.
 2. If a connection has not been established at this point, press the **Establish** Button to establish the connection.

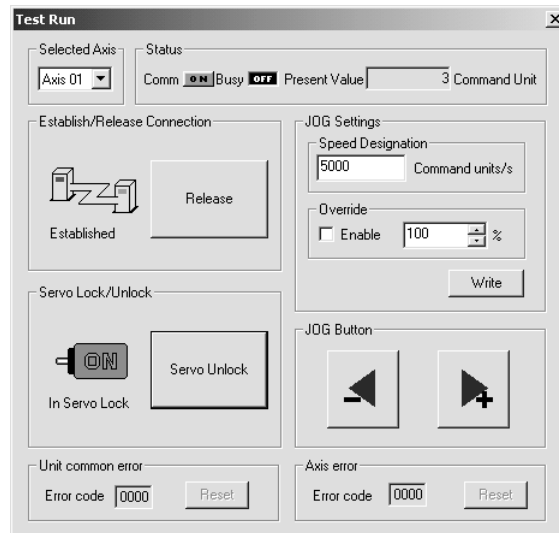

3. Press the **Servo Lock** Button.



4. Enter the desired speed in the *JOG Settings*. To use the override, select the **Enable** Check Box and enter the desired override value. Click the **Write** Button to write the set values to the Position Control Unit.
5. Press  (or ). Jogging will continue while the button is pressed down. Release the button to stop the JOG operation.



Note (1) Pressing a **JOG Button** ( or ) will actually operate the motor at the designated speed. Execute jogging only after confirming safety.

- (2) The operation on the personal computer may not stop the motor. Provide an emergency stop device externally to enable stopping the motor immediately at any time.
- (3) Before starting MECHATROLINK communications, make sure that the PLC is in the PROGRAM mode. If the PLC is in RUN or MONITOR mode, the axis may start moving suddenly due to execution of the ladder program. Before disconnecting MECHATROLINK communications, make sure that the axis is not operating. Disconnecting MECHATROLINK communications will put the operating axis in the Servo-free state.
- (4) If a communications error occurs while the Test Run Window is being displayed, a FINS Command Time Monitor Error will occur in the Position Control Unit. To clear the error, the power for the Position Control Unit must be turned OFF and then turned ON again, the Position Control Unit must be restarted, or the **Unit Error Reset** Button must be pressed to clear the error and close the Test Run Window.

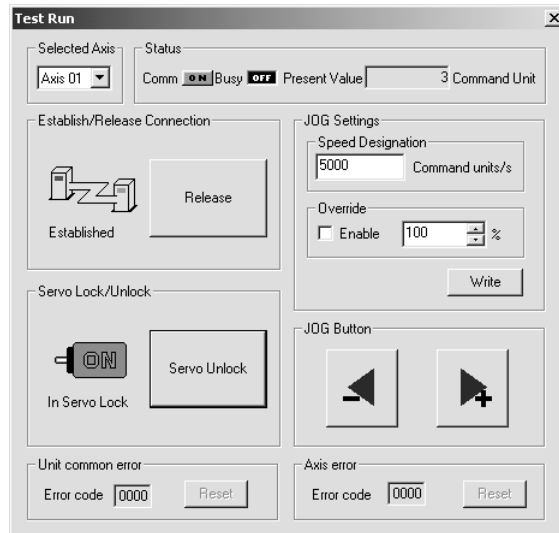
Test Run Window



Item		Explanation	
Selected Axis		Selects the axis to jog. The axes that are registered in the Position Control Unit are displayed.	
Status	Comm	Shows the MECHATROLINK communications status.	
	Busy	Shows the status of the Busy Flag of the selected axis.	
	Present Value	Shows the feedback present value of the selected axis.	
Establish/Release Connection	Release Button	Releases MECHATROLINK communications when clicked.	
	Establish Button	Establishes MECHATROLINK communications when clicked.	
Servo Lock/Unlock	Servo Unlock Button	Executes Servo Unlock when clicked.	
	Servo Lock Button	Executes Servo Lock when clicked.	
JOG Settings	Speed Designation		
	Specifies the speed at the start of jogging. Setting range: 0 to 2,147,483,647 [command units/s]		
	Override	Enable check box	Not selected: Disables override. Selected: Enables override.
		Override value	Sets the override value. Setting range: 1 to 327 [%]
Write Button		Writes the settings in <i>Speed Designation</i> and <i>Override</i> to the Position Control Unit. Make sure to write the settings before executing jogging.	

Item		Explanation
JOG	 Button	Jogs in the forward direction while this button is held down.
	 Button	Jogs in the reverse direction while this button is held down.
Unit common error	Error code	Displays the error codes of errors that have occurred in the Position Control Unit. The code "0000" is displayed when there is no error. Clicking the displayed error code will open the Online Help to show the error contents.
	Reset	Resets an error that has occurred in the Position Control Unit.
Axis error	Error code	Displays the error code of an error that has occurred for the selected axis. The code "0000" is displayed when there is no error. Clicking the displayed error code will open the Online Help to show the error contents.
	Reset	Resets an error that has occurred for the selected axis.

SECTION 10

Absolute Encoder Setup

This section describes the absolute encoder setup operation.

10-1 Absolute Encoder Setup 90

10-1 Absolute Encoder Setup

Precautions

Be sure you understand the following restrictions and take appropriate actions as required before executing the absolute encoder setup operation.

- If a backup error or checksum error occurs in the Servo Drive, it is possible to reset the Servo Drive alarm only with a Position Control Unit with unit version 1.2 or later. If the unit version of the Position Control Unit is version 1.1 or earlier, it is possible to reset only the multi-turn data of the absolute encoder. To confirm the unit version of the Position Control Unit, refer to the IO Table Window of CX-Programmer version 4.0 or higher. For details, refer to *Unit Versions* on page xvii.
- Commands from the ladder program will not be accepted while setting up an absolute encoder.

Setting Up the Absolute Encoder

1. In the Axis Map Setting Window, select **Online - Absolute Encoder Setup - Axis XX** (XX = 01 to 16), or right-click the axis and select **Absolute Encoder Setup** from the pop-up menu.

If the unit version of the connected Position Control Unit is version 1.1 or earlier, the following dialog box will be displayed.

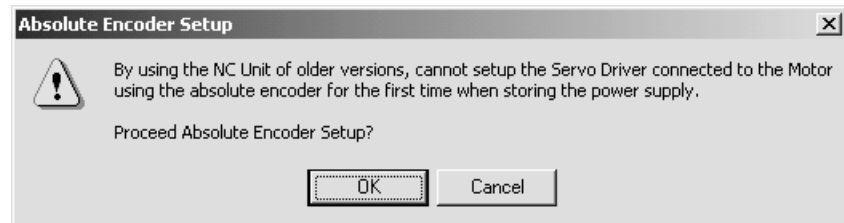

2. When the absolute encoder setup has been completed, the following message will be displayed. Cycle the Servo Drive's power supply when the following message is displayed.

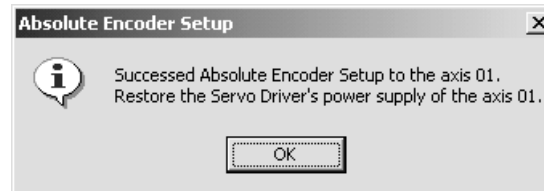

Note

- (1) If the absolute encoder setup is completed successfully, be sure to cycle the Servo Drive's power supply.
- (2) If the Absolute Encoder Setup is not completed, a message may be displayed to cycle the Servo Drive's power supply, or/and restart the Position Control Unit or cycle the PLC's power supply. Cycle the Servo Drive's or PLC's power supply, or/and restart the Position Control Unit according to the message that is displayed.
- (3) After the Absolute Encoder Setup has been completed successfully, multi-turn data in the encoder will be reset to zero, and the previously defined machine system will be changed to a different coordinate system. Be sure to reset the zero point for the machine system. Not doing so may result in unexpected operation.

SECTION 11

Error Log and Troubleshooting

This section provides information on the error log display and troubleshooting methods for the Position Control Unit.

11-1 Error Log	92
11-2 Error Codes	92
11-3 Troubleshooting	111

11-1 Error Log

Overview

A maximum of 11 Position Control Unit errors can be recorded and displayed. Errors thereafter will replace previous errors, starting with the least recent error.

Displaying Error Log

In the Axis Map Setting Window, select **Online - Error Log**, or right-click a Position Control Unit and select **Error Log** from the pop-up menu.

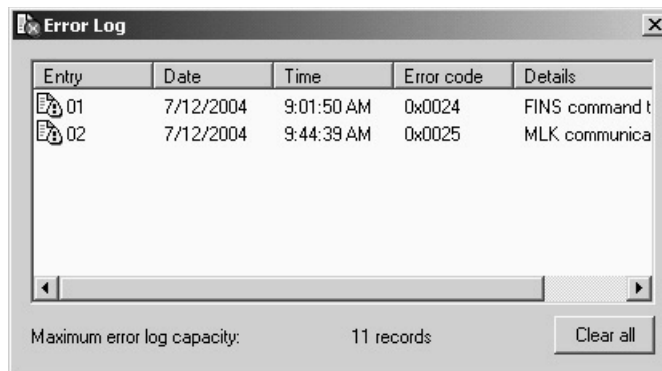

Click the **Clear All** Button to clear the error log (all the records will be deleted).

Note

- (1) The error log cannot be cleared when communications between the Position Control Unit and Servo Drive have started. Stop communications before attempting to clear the error log.
- (2) Axis errors are not included in the error log. Check the Axis Monitor if axis errors occur.

11-2 Error Codes

For details on the probable causes of error codes and methods used to clear errors, refer to *Section 12 Troubleshooting in the CS1W-NCF71/CJ1W-NCF71 Position Control Units Operation Manual* (Cat. No. W426), or select **Help - Help** in the Axis Map Setting Window and refer to the online help.

Position Control Unit Common Errors

	Category	Error name	Error code	Probable cause	Clearing method
CPU Unit error	CPU Unit error	CPU fatal error	000A	An error causing the CPU Unit to stop has occurred.	Remove the cause of the CPU Unit stopping.
		CPU Unit watchdog timer error	000B	The CPU Unit system is not operating correctly.	Make sure that the CPU Unit and Position Control Unit are installed correctly, and turn the power OFF and ON again. If the error occurs again, replace the CPU Unit.
		CPU Unit monitor error	000C	The cyclic refresh from the CPU Unit to the Position Control Unit has stopped.	Check the error status of the CPU Unit and perform appropriate error processing. Restart the cyclic refresh with the CPU Unit, and then execute Position Control Unit's ERROR RESET.
		Bus error	000D	PLC bus operation error	Make sure that the CPU Unit and Position Control Unit are installed correctly, and turn the power OFF and ON again. If the error occurs again, replace the CPU Unit.

	Category	Error name	Error code	Probable cause	Clearing method
Position Control Unit internal errors	Unit error	MLK device error	0026	An error has occurred in the internal circuits of the Position Control Unit.	Replace the Position Control Unit.
		MLK device initialization error	0030	An error has been detected in the MECHATROLINK communications part during Position Control Unit initialization processing.	Check the MECHATROLINK communications settings in the Common Parameters, and then restart the Unit or turn the power OFF and ON again. If the error occurs again, replace the Position Control Unit.
	Data corrupted	Memory error	00F1	The data saved in the Position Control Unit is corrupted.	Transfer and save the Position Control Unit data again, and then restart the Unit or turn the power OFF and ON again. If the error occurs again, replace the Position Control Unit.
MECHATROLINK communications errors	Scan list mismatch	MLK initialization error	0020	The MECHATROLINK slave station device corresponding to the axis number registered in the Position Control Unit scan list is not connected.	Check whether the settings for the MECHATROLINK communications line connection or slave device's station address match the settings in the scan list, and then execute CONNECT again.
	Communications error	MLK communications error	0025	MECHATROLINK communications cannot be performed correctly, or two or more MECHATROLINK slave station devices are using the same station number.	Check the connection of the MECHATROLINK communications cable. Remove the noise or other the cause preventing communications, and then restart the Position Control Unit.

	Category	Error name	Error code	Probable cause	Clearing method
Position Control Unit settings and operations errors	Illegal operation	Multistart error	0021	An operation command that cannot be executed has been sent to the Position Control Unit.	The operation command that was sent cannot be executed. Check the last command timing and change the operation sequence.
		Illegal data	Write transfer error	0022	An attempt has been made for the Position Control Unit to write data to an illegal address, or to write data using an illegal data size.
	Read transfer error		0023	An attempt has been made for the Position Control Unit to read data from an illegal address, or to read data with an illegal data size.	The data transfer for the command cannot be executed. Check the contents of the last command, and correct the data transfer settings.
	FINS command time monitor error	0024	The cables between the personal computer and PLC have been disconnected.	Reconnect the cables, and restart the Position Control Unit.	
			The personal computer's operation is slow.	Exit all other software and then restart the Position Control Unit.	
	Transfer cycle setting error	0027	The set value for the transfer cycle set in the Position Control Unit's Common Parameters is too small for the number and type of connected MECHATROLINK devices or the maximum axis number.	Set and save a transfer cycle set value in the Common Parameters that is suitable for the number and type of connected MECHATROLINK devices and the maximum axis number, and then restart the Position Control Unit.	
	Initialization common parameter check error	0028	An illegal set value has been detected in the Common Parameters during Position Control Unit initialization.	When this error occurs, the corresponding setting in the Common Parameters is set to the default value (0). Execute ERROR RESET, and then transfer and save the correct Common Parameter setting and restart the Position Control Unit.	
	Data transfer common parameter check error	0029	An illegal set value in the Common Parameters was transferred to the Position Control Unit using WRITE DATA.	The transferred set value is discarded and the set value in the Common Parameters before the transfer is restored. Execute ERROR RESET, and then transfer the correct Common Parameters setting.	

Axis Errors

	Category	Error name	Error code	Probable cause	Clearing method
MECHATROLINK communications errors	Communications error	Synchronous communications alarm	3010	MECHATROLINK communications cannot be performed correctly with the corresponding axis.	Check the connection of the MECHATROLINK communications cable. Remove the cause preventing communications, such as breaks or noise in the connection, and then execute CONNECT again.
		Communications alarm	3011	MECHATROLINK communications cannot be performed correctly with the corresponding axis.	Check the connection of the MECHATROLINK communications cable. Remove the cause preventing communications, such as breaks or noise in the connection, and then execute CONNECT again.
		Command time-out	3012	No MECHATROLINK communications response has been received from the corresponding axis.	Check that no error has occurred in the MECHATROLINK device connected to the corresponding axis, and then execute CONNECT again.
Position Control Unit settings and operations errors	Illegal operations	Present position unknown error	3030	ABSOLUTE MOVEMENT or ORIGIN RETURN was executed before the origin was established.	Execute ORIGIN SEARCH or PRESENT POSITION PRESET to define the origin, and then execute the previously unsuccessful command again.
		Servo unlock error	3040	A command to start the axis was executed while in Servo unlock status.	Execute the SERVO LOCK and then execute the previously unsuccessful command again.
		Multistart error	3050	An attempt was made to execute two or more of the following commands at the same time for the same axis. ABSOLUTE MOVEMENT, RELATIVE MOVEMENT, ORIGIN SEARCH, ORIGIN RETURN, PRESENT POSITION PRESET, JOG, SPEED CONTROL, TORQUE CONTROL, DEVICE SETUP, or ERROR RESET	Edit the ladder program so that multiple command bits do not turn ON at the same time for the same axis, and then execute the previously unsuccessful command again.
				An attempt was made to execute one of the following commands for a busy axis. ORIGIN SEARCH, ORIGIN RETURN, PRESENT POSITION PRESET, JOG, DEVICE SETUP, or ERROR RESET	Edit the ladder program so that command bits do not turn ON for a busy axis, and then execute the previously unsuccessful command again.

	Category	Error name	Error code	Probable cause	Clearing method
Position Control Unit settings and operations errors	Illegal data	Position designation error	3060	An attempt was made to execute RELATIVE MOVEMENT using a position command value for the target position that is outside the positioning range.	Edit the position command value to be within the positioning range and execute the command again.
		Speed designation error	3061	An attempt was made to execute one of the following commands with a negative value as the speed command value. ABSOLUTE MOVEMENT, RELATIVE MOVEMENT, ORIGIN SEARCH, ORIGIN RETURN, and JOG	Edit the speed command value to be within the setting range and execute the command again.
				An attempt was made to execute ORIGIN SEARCH with a speed command value of 0.	Edit the speed command value to be within the setting range and execute the command again.
		Speed control speed designation error	3062	An attempt was made to execute SPEED CONTROL using a command value that exceeds the speed command range.	Edit the speed command value to be within the setting range and execute the command again.
		Torque command value error	3063	An attempt was made to execute TORQUE CONTROL using a command value that exceeds the torque command range.	Edit the torque command value to be within the setting range and execute the command again.
		Option command value 1 error	3064	An attempt was made to execute SPEED/TORQUE CONTROL using a command value that exceeds the command range in option command value 1.	Edit the option command value to be within the setting range and execute the command again.
		Option command value 2 error	3065	An attempt was made to execute SPEED CONTROL using a command value that exceeds the command range in option command value 2.	Edit the option command value to be within the setting range and execute the command again.
		Override	3070	An attempt was made to execute the override using an override value outside the setting range.	Edit the override value to be within the setting range and execute the command again.

	Category	Error name	Error code	Probable cause	Clearing method
Position Control Unit settings and operations errors	Illegal data	Initializa- tion axis parameter check error	3090	An illegal set value has been detected in the Axis Parameters during Position Control Unit initialization.	When this error occurs, the corresponding setting in the Axis Parameters is set to the default value (0). Execute ERROR RESET, and then transfer the correct Axis Parameter.
		Data trans- fer axis parameter check error	3091	An illegal set value in the Axis Parameters was transferred to the Position Control Unit using WRITE DATA.	The transferred set value is discarded and the set value in the Axis Parameters before the transfer is restored. Execute ERROR RESET, and then transfer the correct Axis Parameter.
		Data setting error	3099	An attempt was made to transfer data for an illegal parameter number and outside the setting range using SERVO PARAMETER TRANSFER.	The transferred set value is discarded and the set value for the Servo Parameter before the transfer is restored. Execute ERROR RESET, and then transfer the correct Servo Parameter.

	Category	Error name	Error code	Probable cause	Clearing method
MECHA-TROLINK slave station device errors	External sensor input	Forward Rotation limit input	3000	A forward rotation limit input signal was detected.	Execute ERROR RESET, and then perform movement in the reverse rotation direction.
		Reverse Rotation limit input	3001	A reverse rotation limit input signal was detected.	Execute ERROR RESET, and then perform movement in the forward rotation direction.
		Forward software limit	3002	The forward software limit was reached or exceeded during axis movement.	Check the position command value and executing ERROR RESET, and then execute a movement command to move the axis to a correct position within the software limit range.
		Reverse software limit	3003	The reverse software limit was reached or exceeded during axis movement.	Check the position command value and executing ERROR RESET, and then execute a movement command to move the axis to a correct position within the software limit range.
		Emergency stop input	3004	Emergency stop input signal in external control inputs was detected during Servo lock, or Servo lock was executed during inputting the emergency stop signal.	After clearing the emergency stop input, execute the axis error reset and restart operation from Servo lock status. (This error will not occur when executing the Emergency Stop command in Axis Operating Memory.)
	Origin search error	No origin proximity or origin input signal	3020	The origin proximity input signal could not be detected within the range of both limit input signals during an origin search.	Check the origin proximity input signal wiring and the signal's allocation setting in the Servo Parameters. Check that the dog width of the origin proximity input signal is no shorter than the communications cycle.
				After detecting the origin proximity input signal during an origin search operation, a limit input signal was detected before detecting the origin input signal.	Check that the origin input signal selection in the Position Control Unit's Axis Parameters is correct. When the external latch signal is selected as the origin input signal, check the external latch signal wiring and the allocation setting in the Servo Parameters.
		Limit input already ON	3021	The limit input signal in the origin search direction has already been input during a single-direction origin search.	Check the limit input signal wiring for the corresponding direction and check the limit input signal's allocation setting in the Servo Parameters.
		Limit input signal ON in both directions	3022	Origin search cannot be executed due to limit input signals being input in both directions.	Check the limit input signal wiring in both directions and check the limit input signal allocation settings in the Servo Parameters.
	MECHA-TROLINK slave station device errors	Servo Drive error	Servo Drive main circuit OFF error	3080	The main circuit power of the Servo Drive has been turned OFF.
MECHA-TROLINK device alarm		---	4000 + Alarm code for each device	The error processing depends on the device.	

Axis Warnings

	Category	Error name	Error code	Probable cause	Clearing method
MECHATROLINK slave station device	MECHATROLINK device warning	---	4000 + Warning code for each device	The error processing depends on the device.	

OMRON Servo Drive Alarm Display

The following table lists the alarm displays for OMRON Servo Drives.

The alarms that occur in the Servo Drive correspond to error codes that are detected by the Position Control Unit when the MECHATROLINK communications have been established, as shown in the following table.

Refer to the Servo Drive's operation manual for details on alarms and troubleshooting.

Alarm Display

Servo Drive display					Position Control Unit error code	Error detection function	Detected error or cause of error
W Series	W-series (Built-in Communications Type)	SMART-STEP Junior (Built-in communications Type)	G-Series (Built-in communications Type)	G5-Series (Built-in communications Type)			
A.02	A.02□	---	---	---	4002	Parameter corrupted	Parameter checksum read from EEPROM does not match.
---	---	A.02	---	---		Parameter error	Parameter data in the Servo Drive is incorrect.
A.03	A.03□	A.03	---	---	4003	Main circuit detection error	Error in detection data for power supply circuit
A.04	A.04□	A.04	---	---	4004	Parameter setting error	The parameter setting is incorrect.
A.05	A.05□	---	---	---	4005	Servomotor mismatch	The Servomotor and Servo Drive combination is incorrect.
---	---	A.05	---	---		Servo Drive not supported	The Servo Drive has malfunctioned.
---	A.0b□	---	---	---	400B	Servo ON command invalid alarm	An attempt was made to turn ON the servo with a host command after using a function that enables turning ON the servo with a Computer Monitor Software operation.
---	---	---	11	11□		Control power undervoltage	P-N voltage of control power converter unit is under specified value.
---	---	---	12	12□	400C	Overvoltage	Main circuit P-N voltage exceeded specified value. Power voltage is high. Voltage jumps with phase-advance capacitor and UPS (No power interruption device).

Servo Drive display					Position Control Unit error code	Error detection function	Detected error or cause of error
W Series	W-series (Built-in Communications Type)	SMART-STEP Junior (Built-in communications Type)	G-Series (Built-in communications Type)	G5-Series (Built-in communications Type)			
---	---	---	13	---	400D	Main power undervoltage	When Undervoltage Alarm Selection (Pn065) was 1, L1 to L3 experienced power interruption that was longer than time set for Momentary Power Interruption Hold Time (Pn06D) or main circuit P to N voltage decreased under specified value while Servo was turned ON.
---	---	---	---	13□			<ul style="list-style-type: none"> The main circuit DC voltage decreased. Disconnection was detected in the AC power supply of the main circuit.
---	---	---	14	14□	400E	Overcurrent	Overcurrent has occurred.
---	---	---	15	15□	400F	Servo Drive overheat	Servo Drives radiator and power element overheated beyond the specified value.
A.10	A.10□	A.10	---	---	4010	Overcurrent	Overcurrent has occurred or radiator overheated error was detected (3 to 15-kW models only).
---	---	---	16	---		Overload	The effective value of the torque command exceeded the overload level that is set for Overload Level (Pn072).
---	---	---	---	16□		Operation with a much higher torque than the rated value continued for several seconds to several tens of seconds.	
---	---	---	18	18□	4012	Regeneration overload	Regeneration energy exceeded the processing ability of the regeneration resistance.
---	---	---	21	21□	4015	Encoder communications error	Communications between encoder and Servo Drive have failed for the specified number of times, causing an error to be detected. (No response to request from Servo Drive.)
---	---	---	23	23□	4017	Encoder communications data error	Data communications error has occurred, most likely due to noise.
---	---	---	24	---	4018	Deviation counter overflow	The number of position deviation pulses exceeded the setting for the Deviation Counter Overflow Level (Pn209).
---	---	---	---	24□			The number of pulses in the error counter exceeded the setting for the Error Counter Overflow Level (Pn014).

Servo Drive display					Position Control Unit error code	Error detection function	Detected error or cause of error
W Series	W-series (Built-in Communications Type)	SMART-STEP Junior (Built-in communications Type)	G-Series (Built-in communications Type)	G5-Series (Built-in communications Type)			
---	---	---	---	25□	4019	Excessive hybrid error	During fully-closed control, the error between the load position by an external scale and the motor position in the encoder exceeded the number of pulses set for the Internal/ External Feedback Pulse Error Counter Overflow Level (Pn328).
---	---	---	26	---	401A	Overspeed	The motor speed exceeded the specified value for the Overspeed Detection Level (Pn.073).
---	---	---	---	26□			<ul style="list-style-type: none"> The motor speed exceeded the value specified for the Overspeed Detection Level Setting (Pn513). The motor speed exceeded the value specified for the Overspeed Detection Level Setting at Immediate Stop (Pn615).
---	---	---	27	27□	401B	Command error	Operation command resulted in an error.
---	---	---	29	---	401D	Internal deviation counter overflow	The value of internal deviation counter (Internal control unit) exceeded 2 (134,217,728).
---	---	---	---	29□		Error counter overflow	<ul style="list-style-type: none"> After the control power was turned ON in absolute value mode or during the initialization of position information after executing CONFIG, the value of the absolute encoder position (in pulses) divided by the electronic gear ratio exceeded $\pm 2^{31}$ (2,147,483,648). The position deviation value in pulses exceeded $\pm 2^{29}$ (536,870,912). The position command value in command units exceeded $\pm 2^{31}$ (1,073,741,824). The value of "Final Distance for Origin Return (Pn825) multiplied by electronic gear ratio" exceeded $\pm 2^{31}$ (2,147,483,648).
---	---	---	---	30□	401E	Safety input error	The safety input signal turned OFF.
---	---	---	---	33□	4021	Interface I/O duplicate allocation error	An error was detected in the I/O signal settings of the interface.

Servo Drive display					Position Control Unit error code	Error detection function	Detected error or cause of error
W Series	W-series (Built-in Communications Type)	SMART-STEP Junior (Built-in communications Type)	G-Series (Built-in communications Type)	G5-Series (Built-in communications Type)			
---	---	---	34	---	4022	Overrun limit error	The motor exceeded the allowable motor operation range that is set for the Overrun Limit (Pn.026) for the position command input range.
---	---	---	---	34□			The motor exceeded the allowable operation range that is set for the Overrun Limit Setting (Pn514) for the position command input.
---	---	---	36	36□	4024	Parameter error	The data in the parameter save area was corrupted when reading data from EEPROM at powering ON.
---	---	---	37	37□	4025	Parameter Crash	EEPROM write verification data was corrupted when reading data from EEPROM at powering ON.
---	---	---	38	---	4026	Drive prohibit input error	The positive and negative drive prohibit inputs (NOT and POT) were both ON when the Drive Prohibit Input Selection (Pn.004) was set to 0 and the Stop Selection at Drive Prohibit Input (Pn066) was set to 0 or 1. Or, either the POT or NOT input was ON when the Drive Prohibit Input Selection (Pn.004) was set to 2.
---	---	---	---	38□			<ul style="list-style-type: none"> The positive and negative drive prohibit inputs (POT and NOT) were both ON when the Drive Prohibition Input Selection (Pn504) was set to 0. Either the POT or NOT input was ON when the Drive Prohibition Input Selection (Pn504) was set to 2. An operation command (such as for jogging) was executed from the CX-Drive when the Drive Prohibition Input Selection (PN504) was set to 0, MECHATROLINK-II communications were disconnected, and either the POT or NOT input was ON. Either the POT or NOT input was ON while an operation command from the CX-Drive was being executed.
---	---	A.28	---	---	No Code (See note 1.)	Emergency stop	An emergency stop was input during Servomotor operation.

Servo Drive display					Position Control Unit error code	Error detection function	Detected error or cause of error
W Series	W-series (Built-in Communications Type)	SMART-STEP Junior (Built-in communications Type)	G-Series (Built-in communications Type)	G5-Series (Built-in communications Type)			
---	---	---	40	40□	4028	Absolute value system down error (absolute encoder only)	Power supply to encoder and battery power have dropped. Built-in capacitor voltage has dropped below the specified value (3.0 V).
---	---	---	41	41□	4029	Absolute value counter over error (absolute encoder only)	Encoder multi-turn counter exceeded the specified value.
---	---	---	42	42□	402A	Absolute value overspeed error (absolute encoder only)	The motor speed exceeded the specified value when only battery power was supplied during a power interruption.
---	---	---	---	43□	402B	Encoder initialization error protection	An error was detected during initialization of the encoder.
---	---	---	44	44□	402C	Absolute value one-turn counter error (absolute encoder only)	Encoder detected a one-turn counter error.
---	---	---	45	45□	402D	Absolute value multi-turn counter error (absolute encoder only)	Encoder detected a multi-turn counter error.
---	---	---	47	47□	402F	Absolute value status error (absolute encoder only)	Encoder turned more than the specified value when power was turned ON.
A.30	A.30□	---	---	---	4030	Regeneration error	The regenerative circuit was damaged due to large regenerative energy.
---	---	---	48	48□		Encoder Z-phase error	A missing Z-phase pulse was detected for the serial encoder.
---	---	---	49	---	4031	Encoder PS signal error	Logic error in PS signal was detected for 2,500 [P/r] 5 serial encoder.
---	---	---	---	49□		Encoder CS signal error	A logic error in the CS signal was detected for the serial incremental encoder.
A.32	A.32□	---	---	---	4032	Regeneration overload	Regeneration energy exceeded regeneration resistor capacity.
---	---	---	---	50□		External scale connection error	<ul style="list-style-type: none"> An error was detected for the connection of the external scale. An error was detected in the communications data of the external scale.

Servo Drive display					Position Control Unit error code	Error detection function	Detected error or cause of error
W Series	W-series (Built-in Communications Type)	SMART-STEP Junior (Built-in communications Type)	G-Series (Built-in communications Type)	G5-Series (Built-in communications Type)			
A.33	A.33□	---	---	---	4033	Main-circuit power supply setting error	The setting of Pn001.2 (AC/DC input selection) and the AC/DC wiring method used for the main circuit power supply are not the same.
---	---	---	---	51□		External scale status error	An error code was detected for the external scale.
---	---	---	---	55□	4037	Phase-A/B/Z connection error	An error was detected in the phase-A, phase-B, or phase-Z connection of the external scale.
A.40	A.40□	A.40	---	---	4040	Overvoltage	The main circuit DC voltage has exceeded the specified values.
A.41	A.41□	---	---	---	4041	Undervoltage	The main circuit DC voltage is under the specified values.
---	---	A.41	---	---			The power supply was turned ON again before the Servo Drive power supply was turned OFF.
A.51	A.51□	A.51	---	---	4051	Overspeed	The Servomotor rotation speed has exceeded the maximum rotation speed.
---	A.52□	---	---	---	4052	Oscillation alarm	Abnormal oscillation was detected in the motor speed, or an inertia ratio calculation error occurred during autotuning.
---	---	---	82	82□		Node address setting error	The rotary switch value for the Servo Drive node address setting is set out of range (read at power-N).
---	---	---	83	83□	4053	Communications error	A receive data error was detected continuously in MECHATROLINK-II communications.
---	---	---	84	84□	4054	Transfer cycle error	Command cannot be received in transfer cycle of MECHATROLINK-II communications.
---	---	---	---	86□	4056	Watchdog data error	An error was detected in the data for synchronization exchanged every MECHATROLINK-II communications cycle between the master node and slave nodes.
---	---	---	87	---	4057	Immediate stop input error	Immediate input has turned to open.
---	---	---	---	87□		Emergency stop input error	The forced alarm input signal was input.
---	---	---	90	90□	405A	Transfer cycle setting error	There is a problem in the transfer cycle setting.

Servo Drive display					Position Control Unit error code	Error detection function	Detected error or cause of error
W Series	W-series (Built-in Communications Type)	SMART-STEP Junior (Built-in communications Type)	G-Series (Built-in communications Type)	G5-Series (Built-in communications Type)			
---	---	---	---	91□	405B	SYNC command error	A synchronization command error occurred . A synchronization command was executed during the asynchronous MECHATROLINK-II communications.
---	---	---	---	92□	405C	Encoder setting error	In absolute value mode, initialization of the internal position information failed.
---	---	---	93	93□	405D	Parameter setting error	The electronic gear ratio is less than 1/100 or it is larger than 100: Parameter setting has exceeded the allowable range.
---	---	---	95	95□	405F	Motor does not match	The Servomotor are Servo Drive combination is incorrect.
A.71	A.71□	A.71	---	---	4071	Overload	Operating with output torque exceeding 245% of the rated torque.
A.72	A.72□	A.72	---	---	4072	Overload	Operation continuing with output torque at 120% to 245% of the rated torque.
A.73	A.73□	---	---	---	4073	Dynamic brake overload	The rotary energy has exceeded the dynamic brake resistor capacity during dynamic brake operation.
---	---	A.73	---	---			The Servomotor did not stop 3 seconds or more after the Servo Drive was turned OFF.
A.74	A.74□	---	---	---	4074	Inrush resistance overload	The inrush current when power was turned ON exceeded the inrush resistor capacity.
A.7A	A.7A□	---	---	---	407A	Overheat	Overheating in the radiation shield was detected.
---	---	A.7A	---	---		Board over-heated	The Servo Drive has over-heated or the built-in cooling fan has stopped.
A.81	A.81□	---	---	---	4081	Backup error (Absolute encoders only)	The encoder's backup power supply has fallen.
A.82	A.82□	---	---	---	4082	Checksum error (Absolute encoders only)	An encoder memory checksum error has occurred.
A.83	A.83□	---	---	---	4083	Battery error (Absolute encoders only)	The encoder's battery voltage has fallen (to 2.7 V or lower).
A.84	A.84□	---	---	---	4084	Absolute error (Absolute encoders only)	An internal encoder data error has occurred.
A.85	A.85□	---	---	---	4085	Overspeed error (Absolute encoders only)	The Servomotor is rotating at 200 r/min. or more when the encoder power supply is turned ON.

Servo Drive display					Position Control Unit error code	Error detection function	Detected error or cause of error
W Series	W-series (Built-in Communications Type)	SMART-STEP Junior (Built-in communications Type)	G-Series (Built-in communications Type)	G5-Series (Built-in communications Type)			
A.86	A.86□	---	---	---	4086	Encoder overheating (Absolute encoders only)	Overheating in the encoder was detected.
A.b1	---	---	---	---	40B1	Speed command input reading error	The A/D completion signal from the A/D converter is not being output within the fixed interval.
A.b2	---	---	---	---	40B2	Torque command input reading error	The A/D completion signal from the A/D converter is not being output within the fixed interval.
---	A.b3□	A.b3	---	---	40B3	Current detection error	An error occurred in the Servo Drive's current detector.
A.b6	A.b6□	A.b6	---	---	40B6	LSI for communications corrupted	The LSI used for MECHATROLINK communications is corrupted.
A.bF	A.bF□	A.bF	---	---	40BF	System error	A system error in the control circuit was detected.
A.C1	A.C1□	A.C1	---	---	40C1	Runaway detected	The Servomotor rotated in the opposite direction to the command.
---	---	A.C2	---	---	40C2	Incorrect phase detected	Error detected in polarity signal of Servo Motor.
---	---	A.C5	---	---	40C5	Incorrect polarity detected	Error detected in polarity signal of Servo Motor.
A.C8	A.C8□	---	---	---	40C8	Multi-turn data error (Absolute encoders only)	The absolute encoder setup is incorrect.
A.C9	A.C9□	A.C9	---	---	40C9	Encoder error	Communications between the encoder and Servo Drive are not possible.
A.CA	A.CA□	---	---	---	40CA	Encoder parameter error	The parameter settings in the encoder are corrupted.
A.Cb	A.Cb□	---	---	---	40CB	Encoder data error	Data from the encoder is corrupted.
A.CC	A.CC□	---	---	---	40CC	Multi-turn limit discrepancy (Absolute encoders only)	The absolute encoder multi-turn limit for the encoder and Servo Drive do not match.
A.d0	---	---	---	---	40D0	Deviation counter overflow	The number of pulses in the deviation counter has exceeded the deviation counter overflow level set in Pn505.
---	A.d0□	---	---	The number of pulses in the deviation counter has exceeded the deviation counter overflow level set in Pn520.			
---	---	A.d0	---	The position deviation is too large.			

Servo Drive display					Position Control Unit error code	Error detection function	Detected error or cause of error
W Series	W-series (Built-in Communications Type)	SMART-STEP Junior (Built-in communications Type)	G-Series (Built-in communications Type)	G5-Series (Built-in communications Type)			
A.d1	---	---	---	---	40D1	Motor-load deviation over	The deviation between the fully-closed encoder and semi-closed encoder has reached or exceeded the command unit set in Pn51A.
A.E0	---	---	---	---	No code (See note 2.)	No option	The MECHATROLINK-II Application Module is not installed.
---	A.E0□	---	---	---		COM alarm	An error occurred in the Servo Drive.
---	---	A.E0	---	---		Internal synchronization error 1	Communications link between MECHATROLINK-II and Servo Drive has been disconnected.
A.E1	---	---	---	---	No code (See note 2.)	Option timeout	There is no response from the MECHATROLINK-II Application Module.
A.E2	---	---	---	---	No code (See note 2.)	Option WDC error	An error has occurred in the MECHATROLINK-II Application Module. (MECHATROLINK-II Application Module's watchdog timer count)
---	A.E4□	A.E4	---	---	40E4	Transfer cycle setting error	The MECHATROLINK-II transfer cycle setting is incorrect.
A.E5	A.E5□	A.E5	---	---	40E5	Synchronization error	MECHATROLINK-II synchronization error
A.E6	A.E6□	A.E6	---	---	40E6	Communications error	MECHATROLINK-II communications error (Continuous communications errors have occurred.)
A.E7	---	---	---	---	40E7	Option detection error	The MECHATROLINK-II Application Module has been removed.
A.EA	A.EA□	---	---	---	40EA	Servo Drive malfunction	The Servo Drive has malfunctioned.
---	---	A.EA	---	---		Internal synchronization error 2	Communications link between MECHATROLINK-II and Servo Drive has been disconnected.
A.EB	---	---	---	---	40EB	Servo Drive initial access error	The Servo Drive initial processing cannot be executed from the MECHATROLINK-II Application Module.
A.EC	---	---	---	---	40EC	Servo Drive error	An error has occurred in the Servo Drive. (Servo Drive's watchdog timer count)
A.ED	A.ED□	---	---	---	40ED	Command execution incomplete	MECHATROLINK communications command aborted during execution.
---	---	A.ED	---	---		Internal command error	A command error has occurred inside the Servo Drive
A.F1	A.F1□	---	---	---	40F1	Missing phase detected	Main circuit power supply phase is missing, or the wire is burnt out.

Servo Drive display					Position Control Unit error code	Error detection function	Detected error or cause of error
W Series	W-series (Built-in Communications Type)	SMART-STEP Junior (Built-in communications Type)	G-Series (Built-in communications Type)	G5-Series (Built-in communications Type)			
A.F5	---	---	---	---	40F5	Motor current error	The current to the Servomotor is too small for the torque command from the Servo Drive.
A.F6	---	---	---	---	40F6	Motor conduction error	The Servo is ON, but the Servomotor is not conducting current regardless of the Servo Drive settings and external input.

- Note**
- (1) An emergency stop signal (error code: 3004 hex) will be input to the Position Control Unit if the emergency stop signal is input during Servo Motor operation or when attempting to turn ON the Servo while inputting the emergency stop signal.
 - (2) Errors that occur in the MECHATROLINK-II Application Module cannot be detected by the Position Control Unit because the connection is not established. The Position Control Unit is not able to detect the corresponding axis during execution of CONNECT, so an MLK Initialization Error (Unit error code: 0020 Hex) will occur.

Warning Display

Servo Drive display					Position Control Unit error code	Warning detection function	Warning details
W Series	W-series (Built-in Communications Type)	SMART-STEP Junior (Built-in communications Type)	G-Series (Built-in communications Type)	G5-Series (Built-in communications Type)			
A.90	---	---	---	---	4090	Deviation counter overflow	The number of pulses in the deviation counter has exceeded the deviation counter overflow level set in Pn505 multiplied by the rate (%) set in Pn51E.
---	A.90□	---	---	---			The number of pulses in the deviation counter has exceeded the deviation counter overflow level set in Pn520 multiplied by the rate (%) set in Pn51E.
---	---	---	144	---	4090	Overload	The load exceeded 85% of the overload alarm level.
A.91	A.91□	A.91	---	---	4091		The warning occurs before an Overload Alarm (A.71 or A72) occurs. If operation is continued in this state, an alarm may occur.

Servo Drive display					Position Control Unit error code	Warning detection function	Warning details
W Series	W-series (Built-in Communications Type)	SMART-STEP Junior (Built-in communications Type)	G-Series (Built-in communications Type)	G5-Series (Built-in communications Type)			
---	---	---	145	---	4091	Regeneration overload	The regeneration load exceeded 85% of regeneration overload alarm level.
A.92	A.92□	---	---	---	4092		This warning occurs before the Regeneration Overload Alarm (A.32) occurs. If operation is continued in this state, an alarm may occur.
---	---	---	146	---	4092	Battery warning (Absolute encoders only)	Battery voltage of absolute encoder decreased to max about 3.2V (Replace battery while Control circuit power is ON).
A.93	A.93□	---	---	---	4093		This warning occurs before the Battery Error (A.83) occurs. If the power is turned OFF, an alarm may occur the next time the power is turned ON. (Replace the battery while the control circuit power supply is ON.)
---	---	---	147	---	4093	Fan lock warning	Internal cooling fan has stopped or turned abnormally.
A.94	A.94□	A.94	148	94	No code (See note 3.)	Parameter setting warning	A value outside the setting range has been set for the MECHATROLINK slave station device.
A.95	A.95□	A.95	149	95	No code (See note 3.)	MECHATROLINK-II command warning	An illegal communications command or unsupported communications command has been sent to the MECHATROLINK slave station device.
A.96	A.96□	A.96	150	96	4096	Communications warning	A single MECHATROLINK-II communications error has occurred. (See note 4.)
---	---	---	---	A0	40A0	Overload warning	The load rate exceeded 85% of the protection level.
---	---	---	---	A1	40A1	Excessive regeneration warning	The regeneration load rate exceeded 85% of the specified level.
---	---	---	---	A2	40A2	Battery warning	The battery voltage decreased to 3.2 V or lower.
---	---	---	---	A3	40A3	Fan warning	The fan has stopped for 1 second or longer.
---	---	---	---	A4	40A4	Encoder communications warning	The number of continuous occurrences of encoder communications errors exceeded the specified value.

W Series	Servo Drive display				Position Control Unit error code	Warning detection function	Warning details
	W-series (Built-in Communications Type)	SMART-STEP Junior (Built-in communications Type)	G-Series (Built-in communications Type)	G5-Series (Built-in communications Type)			
---	---	---	---	A5	40A5	Encoder over-heating warning	The encoder detected a over-heat warning.
---	---	---	---	A6	40A6	Vibration detection warning	Vibration was detected.
---	---	---	---	A7	40A7	Limit detection warning	The remaining service life of a capacitor or a fan is shorter than the specified value.
---	---	---	---	A8	40A8	External scale error warning	The external scale detected a warning.
---	---	---	---	A9	40A9	External scale communications warning	The number of external scale communications errors exceeded the specified value.

- Note**
- (3) If a Parameter Setting Warning or MECHATROLINK-II Command Warning occurs in the Servo Drive, a data setting error (axis error code: 3099) will occur at the Position Control Unit, and the active axis in which the error occurred will decelerate to a stop.
 - (4) If a MECHATROLINK-II communications error occurs once independently, a communications warning occurs, and the Position Control Unit will perform a communications retry. If the communications warning occurs continually, a communications error will occur.

11-3 Troubleshooting

Error Messages When Connecting Online and Their Remedies

When attempting to connect online in the CX-Motion-NCF Basic Window, the following dialog box may be displayed. The following flowchart shows the causes and remedies.

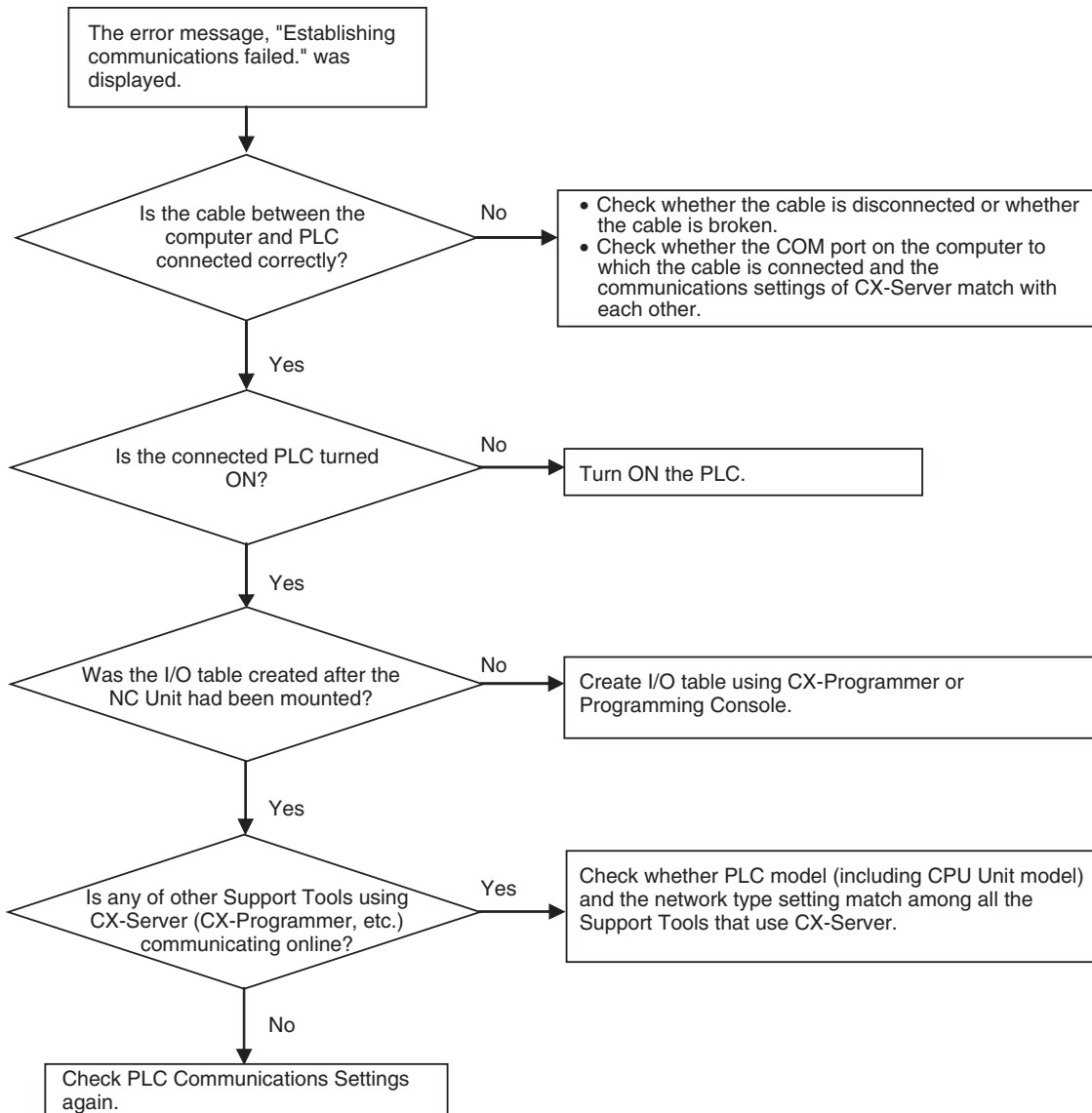

Error Messages and Remedies

The causes and remedies of the error messages that are displayed through online operations are explained here.

Message	Probable cause	Remedy
The connected unit is not a Position Control Unit.	The connected Unit is not the CJ1W-NCF71 or CS1W-NCF71.	Check whether the connected Unit is the CJ1W-NCF71 or CS1W-NCF71.
	The Unit No. is not correct.	Change the Unit No. either in the Unit or in the CX-Motion-NCF.
Axis types in NC Unit and CX-Motion-NCF tool are different. The operation cannot be continued.	The model (i.e., axis type) set in the CX-Motion-NCF is different from the model of the Position Control Unit.	Change the axis type of the Position Control Unit.
The MECHATROLINK slave station device corresponding to the axis number registered in the Position Control Unit scan list is not connected. Check whether the settings for the MECHATROLINK communications line connection or slave device's station address match the settings in the scan list, and then execute CONNECT again.	The axis map (scan list) does not match with the actual configuration of the Servo Drives.	Add or delete axes appropriately in the Axis Map Setting Window, set appropriate axis numbers, and transfer the axis map to the Unit. Otherwise, change the axis numbers in the Servo Drives appropriately.
Cannot start communications with the Position Control Unit. Check the Unit No. of the Position Control Unit.	The Unit No. is not correct, or the Unit corresponding to the Unit No. does not exist.	Check the Unit No. of the Position Control Unit.
	Communications with the Position Control Unit could not be established because the I/O table has not been created.	Create the I/O table.
Stop communications. The Position Control Unit is busy.	Data could not be transferred from the CX-Motion-NCF because parameters were being transferred from the ladder program.	Stop parameter transfer from the ladder program first, and then transfer data from the CX-Motion-NCF.
Stop communications. The axis □□ is busy.	Data could not be transferred from the CX-Motion-NCF because parameters were being transferred from the ladder program.	Stop parameter transfer from the ladder program first, and then transfer data from the CX-Motion-NCF.
An error has occurred in the Servo Drive of axis □□. Check the error of the Servo Drive and remove the cause. Check if the parameters not supported by the Servo Drive or out of setting range are transferred.	<ul style="list-style-type: none"> Transferring data caused an error in the Servo Drive. An error occurred in the Servo Drive during transfer. 	Check the error code and provide appropriate remedy to clear the error.
Clearing the error log failed. Connection has been established.	MECHATROLINK communications have been established.	Stop the communications (i.e., release the connection).
Transferring Servo Parameters failed. An error has occurred on axis □□.	An error has occurred in the Servo Drive.	Check the error code and provide appropriate remedy to clear the error.
Could not acquire access right. Another user is currently occupying the Unit.	The Position Control Unit is being operated from another personal computer.	Stop any online operations from another personal computer.
Cannot connect to the Position Control Unit. Check the following items. <ul style="list-style-type: none"> Whether the PLC has been turned ON. Whether the connection cable has not been disconnected. 	The PLC has not been turned ON.	Turn ON the PLC.
	The cable between the PLC and personal computer has been disconnected.	Check the connection of the cable.
	Communications failed midway due to noise, etc.	Execute the online operation again.
	MECHATROLINK communications failed due to noise or other cause during execution of the absolute encoder setup operation.	Check the connections of the MECHATROLINK communications cable.

Message	Probable cause	Remedy
<p>Cannot connect to the Position Control Unit. Check the following items.</p> <ul style="list-style-type: none"> -The PLC has been turned ON. -The connection cable has been connected. 	The PLC has not been turned ON.	Turn ON the PLC.
	The cable between the PLC and personal computer has been disconnected.	Check the cable connections.
	Communications failed due to noise or other cause.	Execute the operation to go online again.
	MECHATROLINK communications failed due to noise or other cause when setting up the absolute encoder.	Check the connections of the MECHATROLINK communications cable.
<p>Could not establish communications with the Servo Drive. Check for unit and axis errors.</p>	MECHATROLINK communications settings are not correct.	Change the communications settings in the Unit Parameters and transfer them to the Position Control Unit.
	The axis map (scan list) does not match with the actual configuration of the Servo Drives.	Add or delete axes appropriately in the Axis Map Setting Window, set appropriate axis numbers, and transfer the axis map to the Unit. Otherwise, change the axis numbers in the Servo Drives appropriately.
	An error that cannot be cleared from the CX-Motion-NCF has occurred in the Servo Drive.	Clear the error in the Servo Drive.
	Wiring for the MECHATROLINK communications is not correct.	Check whether the MECHATROLINK cable has been disconnected or wired correctly.
	The Servo Drive has not been turned ON.	Turn ON the Servo Drive.
<p>There are mismatches between the parameters in the Position Control Unit and transferred parameters. Transfer default values of the Unit Parameters to the Position Control Unit and write them to the flash memory. After restarting the Position Control Unit, transfer the parameters again.</p>	Unit Parameters could not be transferred because the scan list in the Position Control Unit did not match with the axis map of the Unit Parameters on the CX-Motion-NCF.	Transfer the default values of the Unit Parameters from the CX-Motion-NCF. Write them to the flash memory. Restart the Position Control Unit, and then transfer the parameters again.
<p>Failed to send a command to the Servo Drive. Stop communications.</p>	Setting up an absolute encoder was attempted for an incremental encoder.	Check the type of encoder used by the Servo Drive.
	Setting up an absolute encoder was attempted for an absolute encoder that was set to operate as an incremental encoder.	Check the setting of Servo parameter P002.2.
	Setting up an absolute encoder was attempted when there was an error other than a Servo Drive backup error or checksum error.	Check the Servo Drive error code and clear the error.

Index

A

- absolute encoder
 - setup, 89
- alarm display
 - for Servo Drive, 99
- applications
 - precautions, xxi
- automatic communications settings, 37
- Axis Map Setting Window, 21
- Axis Monitor, 73
 - common items, 78
 - present value, 79
- Axis Parameters
 - editing, 37

B

- Basic Monitor, 78
- Basic Window, 14
- batch comparing, 61
- batch downloading, 52
- batch uploading, 57

C

- C2 Master connection, 36
- comments, 29
- communications parameters
 - editing, 36
- communications retries, 36
- communications settings, 50
 - automatic, 37
- comparing
 - batch, 61
 - Servo Parameters, 64
 - Unit Parameters, 63
- compatibility
 - computers, 3
- connection cables, 9
- connections
 - establishing/releasing, 84
 - methods, 9
 - online, 8, 50
 - to PLC, 8
- CX-Motion-NCF
 - overview, 2

- package contents, 4
- quitting, 18
- starting, 17
- version information, 20

D

- downloading
 - batch, 52
 - Servo Parameters, 52, 56
 - Unit Parameters, 52, 54

E

- Edit Parameter Window, 15
- editing
 - Axis Parameters, 37
 - communications parameters, 36
 - memory area parameters, 35
 - Servo Parameters, 39
- electromagnetic fields, xxi
- encoder
 - absolute encoder setup, 89
- encoder type, 38
- error codes, 92
- error log
 - displaying, 92
- error messages and troubleshooting, 112
- exporting, 45

F

- flash memory
 - writing to, 66
- function list, 4

H

- Help Menu, 19, 21, 23

I

- importing, 45
- initial settings, 50
- initializing
 - Servo Parameters, 41
- installation

location, xxi
interrupt input signal, 38

J

JOG execution, 85

M

Main Menu, 19
 names and functions, 22
memory area parameters, 35
Monitor Window, 16

N

noise, xxi

O

online connection, 8, 50
operating environment
 precautions, xxi
operations
 list, 24
origin input signal, 38
origin search direction, 38
origin search operation, 38
override, 85

P

personal computers
 compatibility, 3
PLC connections, 8
Position Control Units
 adding Servo Drive, 30
 adding to projects, 29
 copying Servo Drive, 31
 deleting, 30
 deleting Servo Drive, 32
power supply, xxi
precautions, xix
 applications, xxi
 general, xx
 operating environment, xxi
 safety, xx

Present Position Monitor, 73
printing
 procedure, 46
 samples, 47
projects
 adding Position Control Units, 29
 deleting Position Control Units, 30
 reading, 44
 saving, 44

R

radioactivity, xxi
reading
 projects, 44

S

safety precautions, xx
saving
 projects, 44
Servo Drive
 adding to Position Control Unit, 30
 alarm display, 99
 copying to Position Control Unit, 31
 deleting from Position Control Unit, 32
Servo lock/unlock, 84
Servo Parameters
 comparing, 64
 downloading, 52, 56
 editing, 39
 exporting, 46
 initializing, 41
 uploading, 60
Servo status, 80
software structure, 3
static electricity, xxi
status bar, 20
system configuration, 4

T

Test Run Window, 86
toolbar, 19, 23
 icons, 24
transfer cycle, 36
transferring programs, xx

U

- Unit Monitor, 70
 - common items, 71
- Unit Parameters
 - comparing, 63
 - downloading, 52, 54
 - editing, 34
 - uploading, 59
- Unit Status Monitor, 71
- uploading
 - batch, 57
 - Servo Parameters, 60
 - Unit Parameters, 59

V

- version information
 - CX-Motion-NCF, 20

W

- windows
 - Axis Map Setting Window, 21
 - Basic Window, 14
 - Edit Parameter Window, 15
 - Monitor Window, 16
 - Test Run Window, 86

Revision History

A manual revision code appears as a suffix to the catalog number on the front cover of the manual.

Cat. No. W436-E1-12

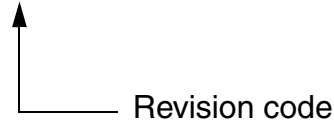

The following table outlines the changes made to the manual during each revision. Page numbers refer to the previous version.

Revision code	Date	Revised content
01	August 2004	Original production
02	February 2005	<p>Page v: Signal word definitions changed.</p> <p>Page ix: Paragraph and sentence on the CX-One added.</p> <p>Page x: Three pages added and version upgrade information added.</p> <p>Page xiii: Information on changing Startup Mode added.</p> <p>Page 3: Information added at top of page.</p> <p>Pages 5 and 30: Information on device information added.</p> <p>Page 6: Section references added.</p> <p>Pages 8 to 15: Installation information replaced.</p> <p>Page 16: “CS” changed to “CS/CJ.”</p> <p>Page 23: Paragraph added in middle of page.</p> <p>Page 29: “Properties” changed to “Displaying Servo Driver Properties.”</p> <p>Page 32: Heading added at top of page and procedure added in middle of page.</p> <p>Page 33: “Registered” added.</p> <p>Pages 34, 40, and 57: Notes added.</p> <p>Page 35: “A new Servo Driver will be added” changed and “Servo Driver” added.</p> <p>Pages 41 and 86: Notes deleted.</p> <p>Page 42: “Pn816” changed to “Pn816.0” in note.</p> <p>Page 45: First sentence in “Initializing Servo Parameters” changed.</p> <p>Page 59: Sentence removed from bottom of page.</p> <p>Pages 61 and 65: “Position Control Unit” added.</p> <p>Pages 67, 68, and 84 to 86: Graphic replaced.</p> <p>Page 75: “Position Control Unit or Servo Driver” added.</p> <p>Pages 80 and 82: Units changed in table.</p> <p>Page 81: “Servo ON Flag” removed from table.</p> <p>Pages 96 to 98: Columns added and rows added or changed (400B, 4052, 40B3, 40D0, 40D1 to 40E4, AND 4090.</p> <p>Page 100: Cells joined in right column.</p> <p>Page 102: Bottom half of table deleted.</p>

Revision History

Revision code	Date	Revised content
03	November 2005	<p>Writing style unified for certain aspects of the manual. The following changes were made to update to version 1.3 and correct information in the manual.</p> <p>Page xiv: Version upgrade information and unit version information added. Page xvi: Last warning and first caution modified and last warning changed to a caution in <i>Safety Precautions</i>. Page xvii: Third application precaution modified. Pages ix, 42, 44, 45, and 104: CS1W-NCF71 added. Page 2: Minor section added. Pages 2, 22, 25, 26, 27, 29, 36, 37, 39, 40, 71, 72, and 73: Figure replaced. Page 5: Introduction to <i>1-2 System Configuration</i> changed. Page 6: Description of <i>Device information</i> changed and <i>Error information</i> row removed from table. Pages 6, 30, 33, and 93: Absolute Encoder Setup operation added. Page 32: "CX-One" added. Page 33: Description of <i>Displaying device information</i> changed. Page 36: Section <i>4-1 Creating a New Project</i> replaced. Page 45: Next to last row of table corrected. Page 58: NSJ Controller added. Page 105: Row added to table under <i>Cannot connect to the NC Unit...</i> and rows added to end of table.</p>
04	July 2006	<p>Pages ix, 3, and 10: Cat. No. and models changed. Pages xiv and 2: Information on CP-series PLCs added. Page 3: Table replaced. Page 19: Heading added. Page 20: Section added. Page 89: Screen shot replaced.</p>
05	November 2006	<p>Changes were made to upgrade to software version 1.4</p> <p>Page xiv: Version upgrade information added for version 1.4. Page xvi: CS1W-NCF71 added. Page xvi: Information added on unit version 2.0. Pages xvi and 108 to 111: Information added on SMARTSTEP Junior Servo Drivers. Page 13: Step added to procedure. Page 40: Information added to note. Page 47: First two rows of table combined. Pages 46, 48, 55, 111, xvi: Note added. Page 48: Screen capture replaced and steps added to procedure. Page 57: Printing sample replaced. Pages 63, 66, 68, 70, 72, 75, 80, 83, and 94: Screen capture replaced. Page 86: Screen capture replaced. Page 90: Additions made to status monitor table. Page 108: Section heading changed.</p>
06	June 2007	<p>Pages ix and 2: Operating system added. Page xiv: Improvements updated. Page 3: Information on applicable computers replaced and deleted. Page 4: Section on checking the package deleted. Pages 10 and 11: Information on software replaced and sections on preparing installation deleted. Pages 12 to 19: Sections on installing and uninstalling CX-Motion-NCF and CX-Server deleted. Page 117: Information on Windows 2000 SP2 deleted.</p>

Revision History

Revision code	Date	Revised content
07	June 2008	Page ix: Changed applicable OS's, model numbers, and version numbers. Page xv: Added version information. Page 2: Changed applicable OS's. Page 3: Changed version number and deleted last sentence. Page 10: Added section 2-2-3. Page 29: Added information on G-series Servo Drives. Page 35: Added note. Page 36: Changed notes. Pages 97 to 101: Added alarms and warnings.
08	October 2008	Added information for new version.
09	September 2009	Added information on G5-series Servo Drivers.
10	December 2009	Changes were made to upgrade to software version 1.91.
11	October 2010	Made revisions for the changing system requirements.
12	April 2016	Made revisions accompanying support for Windows 10 and a change in the CX-One model number.

Revision History

OMRON Corporation Industrial Automation Company

Kyoto, JAPAN

Contact: www.ia.omron.com

Regional Headquarters

OMRON EUROPE B.V.

Wegalaan 67-69, 2132 JD Hoofddorp
The Netherlands
Tel: (31)2356-81-300/Fax: (31)2356-81-388

OMRON ELECTRONICS LLC

2895 Greenspoint Parkway, Suite 200
Hoffman Estates, IL 60169 U.S.A.
Tel: (1) 847-843-7900/Fax: (1) 847-843-7787

OMRON ASIA PACIFIC PTE. LTD.

No. 438A Alexandra Road # 05-05/08 (Lobby 2),
Alexandra Technopark,
Singapore 119967
Tel: (65) 6835-3011/Fax: (65) 6835-2711

OMRON (CHINA) CO., LTD.

Room 2211, Bank of China Tower,
200 Yin Cheng Zhong Road,
PuDong New Area, Shanghai, 200120, China
Tel: (86) 21-5037-2222/Fax: (86) 21-5037-2200

Authorized Distributor:

© OMRON Corporation 2004-2016 All Rights Reserved.
In the interest of product improvement,
specifications are subject to change without notice.

Cat. No. W436-E1-12

0416