



CJ Series

**General-purpose Serial Connection Guide
(RS-485 CompoWay/F Communications)**

OMRON Corporation

KM50 Smart Power Monitor

About Intellectual Property Rights and Trademarks

Microsoft product screen shots reprinted with permission from Microsoft Corporation.

Windows is a registered trademark of Microsoft Corporation in the USA and other countries.

Company names and product names in this document are the trademarks or registered trademarks of their respective companies.

Table of Contents

1. Related Manuals	1
2. Terms and Definitions	2
3. Remarks	3
4. Overview	5
5. Applicable Devices and Support Software.....	6
5.1. Applicable Devices.....	6
5.2. Device Configuration.....	7
6. Serial Communications Settings	9
6.1. Serial Communications Settings	9
6.2. Cable Wiring Diagram.....	10
6.3. Example of Connection Check.....	12
7. Connection Procedure	13
7.1. Work Flow	13
7.2. Setting Up the Smart Power Monitor.....	15
7.3. Setting Up the PLC	17
7.4. Checking the Serial Communications	37
8. Initialization Method.....	43
8.1. Initializing the PLC	43
9. Program.....	45
9.1. Overview	45
9.2. Communications Sequence	49
9.3. Error Detection Processing	50
9.4. Memory Maps	52
9.5. Ladder Program	56
9.6. Protocol Macro Data	62
9.7. Timing Charts.....	73
9.8. Error Process	74
10. Revision History	77

1. Related Manuals

The table below lists the manuals related to this document.

To ensure system safety, make sure to always read and heed the information provided in all Safety Precautions, Precautions for Safe Use, and Precaution for Correct Use of manuals for each device which is used in the system.

Cat. No.	Model	Manual name
W472	CJ2H-CPU6[]-EIP CJ2H-CPU6[] CJ2M-CPU[][]	CJ-series CJ2 CPU Unit Hardware User's Manual
W473	CJ2H-CPU6[]-EIP CJ2H-CPU6[] CJ2M-CPU[][]	CJ-series CJ2 CPU Unit Software User's Manual
W336	CJ1W-SCU[]1-V1 CJ1W-SCU[]2	CJ-series Serial Communications Boards and Serial Communications Units Operation Manual
W446	-	CX-Programmer Operation Manual
W344	-	CX-Protocol Operation Manual
W474	CJ2[]-CPU[][]	CJ-series Instructions Reference Manual
N163	KM50-C[]-[]	KM50-C Smart Power Monitor Operation Manual
9497202-1	KM50-C[]-[]	KM50-C Smart Power Monitor Instruction Manual
N164	KM50-E[]-[]	KM50-E Smart Power Monitor Instruction Manual
9497231-5	KM50-E[]-[]	KM50-E Smart Power Monitor Instruction Manual
N165	KM50-[]-FLK	KM50 Communications Manual



2. Terms and Definitions

Term	Explanation and Definition
Protocol macro	A protocol macro is a function that stores a data send/receive procedure (protocol) in a Serial Communications Board or Serial Communications Unit to exchange data with general-purpose external devices by executing the PMCR instruction on the CPU Unit.
Protocol	A unit of independent communication processing with a specific general-purpose device. A protocol includes a data send/receive procedure. A protocol consists of multiple sequences.
Sequence	A unit of the independent communication processing which can be started by executing the PMCR instruction of a ladder program. A sequence that is started will execute steps registered in its own sequence.
Step	A unit to execute any one of the followings: message send processing, message receive processing, message send/receive processing, clear receive buffer, or step wait. Up to 15 steps can be set per sequence.
Send message	A communication frame (command) sent to the external general-purpose device. A send message is read from the step in the sequence, and sent to the external general-purpose device.
Receive message	A communication frame (response) sent from the external general-purpose device. A receive message is read from the step in the sequence and is compared with data received from the general-purpose external device.
Matrix	A matrix is used when a general-purpose external device sends multiple types of communications frames (responses). More than one communication frame can be registered in one matrix.
Case	A unit to register multiple communication frames (response) to a matrix. One communication frame is registered as one case. Up to 15 types of cases can be registered per matrix.

3. Remarks

- (1) Understand the specifications of devices which are used in the system. Allow some margin for ratings and performance. Provide safety measures, such as installing safety circuit in order to ensure safety and minimize risks of abnormal occurrence.
- (2) To ensure system safety, always read and heed the information provided in all Safety Precautions, Precautions for Safe Use, and Precaution for Correct Use of manuals for each device used in the system.
- (3) The user is encouraged to confirm the standards and regulations that the system must conform to.
- (4) It is prohibited to copy, to reproduce, and to distribute part or the whole of this document without the permission of OMRON Corporation.
- (5) The information contained in this document is current as of February 2013. It is subject to change without notice for improvement.

The following notation is used in this document.

 WARNING	Indicates a potentially hazardous situation which, if not avoided, will result in minor or moderate injury, or may result in serious injury or death. Additionally there may be significant property damage.
 Caution	Indicates a potentially hazardous situation which, if not avoided, may result in minor or moderate injury or in property damage.



Precautions for Safe Use

Precautions on what to do and what not to do to ensure safe usage of the product.



Precautions for Correct Use

Precautions on what to do and what not to do to ensure proper operation and performance.



Additional Information

Additional information to read as required.

This information is provided to increase understanding or make operation easier.

Symbol



The filled circle symbol indicates operations that you must do.
 The specific operation is shown in the circle and explained in text.
 This example shows a general precaution for something that you must do.

4. Overview

This document describes the procedure for connecting the Smart Power Monitor (KM50 Series) of OMRON Corporation (hereinafter referred to as OMRON) to CJ-series Programmable Controller + Serial Communications Unit (hereinafter referred to as the PLC) and provides the procedure for checking their connection.

Refer to the serial communications settings described in 6. Serial Communications Settings and 7. Connection Procedure to understand the setting method and key points to connect the devices via serial communications.

The user program in the prepared CX-Programmer project file and the protocol data in the prepared CX-Protocol project file are used to check the serial connection by sending/receiving the message of Unit Properties Read (sequence No. 618) to/from the destination device.

Prepare the latest CX-Programmer project file and the CX-Protocol project file beforehand. To obtain the files, contact your OMRON representative.

Name	File name	Version
CX-Programmer project file (extension: cxp)	OMRON_KM50_PMCR_EV1_00.cxp	Ver.1.00
CX-Protocol project file (extension: psw)	OMRON_KM50_PMCR_EV1_00.psw	Ver.1.00

*Hereinafter, the CX-Programmer project file is referred to as the "project file".

The user program in the project file is referred to as the "ladder program" or "program".

The CX-Protocol project file is called the "Protocol macro data".

Caution

This document aims to explain the wiring method and communications settings necessary to connect the corresponding devices and provide the setting procedure. The program used in this document is designed to check if the connection was properly established and is not designed to be constantly used at a site. Therefore, functionality and performances are not sufficiently taken into consideration. When you construct an actual system, please use the wiring method, communications settings and setting procedure described in this document as reference and design a new program according to your application needs.



5. Applicable Devices and Support Software

5.1. Applicable Devices

The applicable devices are as follows:

Manufacturer	Name	Model
OMRON	CJ2 CPU Unit	CJ2[]-CPU[][]
OMRON	Serial Communications Unit	CJ1W-SCU[]1-V1 CJ1W-SCU[]2
OMRON	Smart Power Monitor	KM50-E1-FLK KM50-C1-FLK
OMRON	CT	KM20-CTF-[]A



Precautions for Correct Use

As applicable devices above, the devices with the models and versions listed in Section 5.2. are actually used in this document to describe the procedure for connecting devices and checking the connection.

You cannot use devices with versions lower than the versions listed in Section 5.2.

To use the above devices with versions not listed in Section 5.2 or versions higher than those listed in Section 5.2, check the differences in the specifications by referring to the manuals before operating the devices.



Additional Information

This document describes the procedure to establish the network connection. Except for the connection procedure, it does not provide information on operation, installation or wiring method. It also does not describe the functionality or operation of the devices.

Refer to the manuals or contact your OMRON representative.

5.2. Device Configuration

The hardware components to reproduce the connection procedure of this document are as follows:

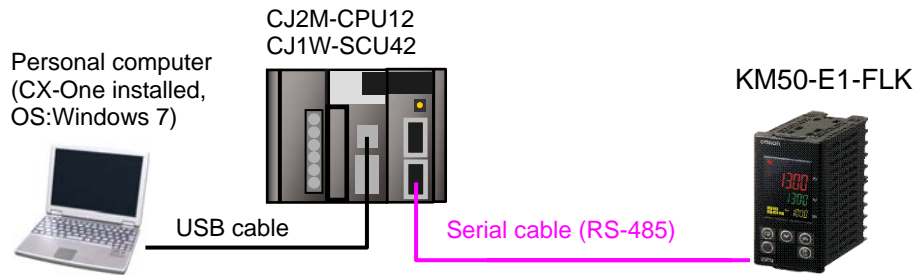

Manufacturer	Name	Model	Version
OMRON	Serial Communications Unit	CJ1W-SCU42	Ver.2.0
OMRON	CPU Unit	CJ2M-CPU12	Ver.2.0
OMRON	Power Supply Unit	CJ1W-PA202	
OMRON	CX-One	CXONE-AL□□C-V4 /AL□□D-V4	Ver.4.□□
OMRON	CX-Programmer	(Included in CX-One)	Ver.9.41
OMRON	CX-Protocol	(Included in CX-One)	Ver.1.96
OMRON	CX-Programmer project file (ladder program)	OMRON_KM50_PMCR_ V1_00.cxp	Ver.1.00
OMRON	CX-Protocol project file (Protocol macro data)	OMRON_KM50_PMCR_ V1_00.psw	Ver.1.00
-	Personal computer (OS: Windows7)	-	
-	USB cable USB 2.0 type B connector	-	
-	Serial cable (RS-485)	-	
OMRON	Smart Power Monitor	KM50-E1-FLK	



Precautions for Correct Use

Prepare the latest project file and protocol macro data in advance.
To obtain the file, contact your OMRON representative.



Precautions for Correct Use

Update the CX-Programmer and CX-Protocol to the version specified in this section or higher version using the auto update function. If a version not specified in this section is used, the procedures described in Section 7 and subsequent sections may not be applicable. In that case, use the equivalent procedures described in the CX-Programmer Operation Manual (Cat. No. W466) and the CX-Protocol Operation Manual (Cat. No. W344).



Additional Information

It may not be possible to reproduce the same operation with different devices or versions. Check the configuration, model and version. If they are different from your configuration, contact your OMRON representative.



Additional Information

Refer to *3-4 RS-232C and RS-422A/485 Wiring* in the *CJ Series Serial Communications Units Operation Manual* (Cat. No. 336) for information on the serial communication cable (RS-485).



Additional Information

The system configuration in this document uses USB for the connection between the personal computer and PLC.

6. Serial Communications Settings

This section describes the specifications such as communication parameters and wiring that are defined in this document.



Additional Information

To perform communications without using the settings described in this section, you need to modify the program. For information on the program, refer to *Section 9. Program*.

6.1. Serial Communications Settings

The serial communications settings are shown below.

Setting item	Serial Communications Unit	Smart Power Monitor
(Communications)Unit number	0	1 (Default)
Communications (connection) port	Port 1 (RS-422/485)	-
TERM (Terminating resistance ON/OFF switch)	ON (Terminating resistance ON)	-
WIRE (2-wire or 4-wire selector switch)	2 (2-wire)	2-wire (Fixed)
Serial communications mode	Protocol macro	-
Data length	7 bits (Default)	7 bits (Default)
Stop bit	2 bits (Default)	2 bits (Default)
Parity	Even (Default)	Even (Default)
Baud rate	9,600 bps (Default)	9,600 bps (Default)
Protocol macro transmissions	Half-duplex (Default)	-
Communications method	-	CompoWay/F (Default)
Check code	-	BCC (Fixed)



Precautions for Correct Use

This document describes the setting procedure of the CJ1W-SCU42 Serial Communications Unit with unit number 0 and communications (connection) port 1. To connect devices under different conditions, change the control word of the CIO area and the PMCR instruction used in the program. Refer to *9. Program* for details.

6.2. Cable Wiring Diagram

Refer to *Section 3. Installation and Wiring of the CJ Series Serial Communications Boards, Serial Communications Units Operation Manual* (Cat. No. 336) for details on cable wiring. Check the connector configuration and pin assignment before wiring.

6.2.1. Wiring of KM50-E1-FLK

■ Connector configuration and pin assignment

<KM50-E1-FLK> Applicable connector: Terminal block

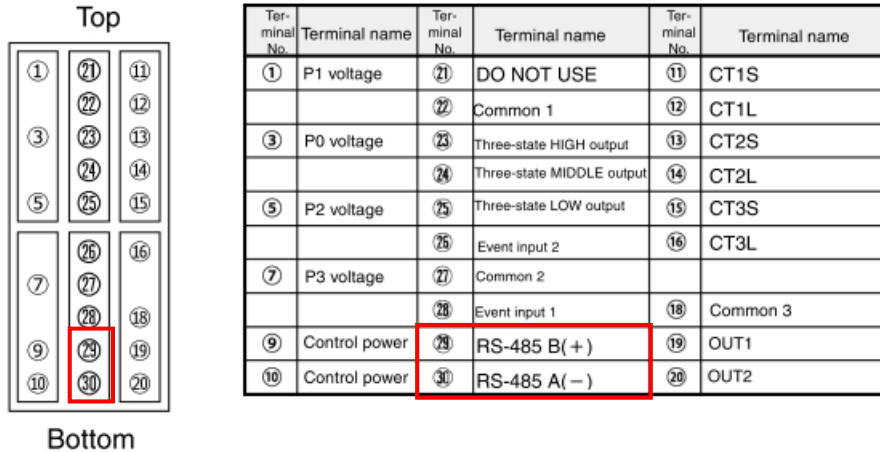

<OMRON CJ1W-SCU42> Applicable connector: Terminal block

Connector Pin Layout

Pin No.	Symbol	Signal name	I/O
1 (See note 1.)	RDA	Receive data -	Input
2 (See note 1.)	RDB	Receive data +	Input
3 (See note 1.)	SDA	Send data -	Output
4 (See note 1.)	SDB	Send data +	Output
5 (See note 2.)	FG	Shield	---

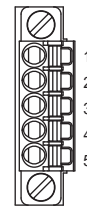

Note 1. For 2-wire connections, use either pins 1 and 2 or pins 3 and 4.

2. Pin 5 (the shield) is connected to the GR terminal on the Power Supply Unit though the Serial Communications Unit. The cable shield can thus be grounded by grounding the GR terminal of the Power Supply Unit.

■ Cable/Pin assignment

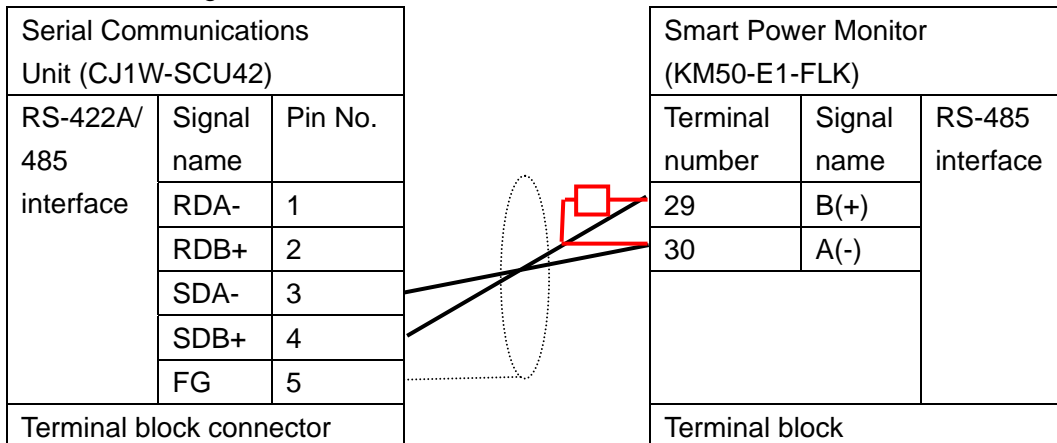

*Connect a terminating resistor of 120 Ω (1/2W) between terminals 29 and 30 of KM50-E1-FLK mounted at the end of the network.



Precautions for Correct Use

Turn ON the terminating resistance switch on the Serial Communications Unit and connect a terminating resistor of 120Ω (1/2W) to the Smart Power Monitor mounted at the end of the network as shown in the pin assignment above.

6.2.2. Wiring of KM50-C1-FLK

■ Connector configuration and pin assignment

<KM50-C1-FLK> Applicable connector: Terminal block

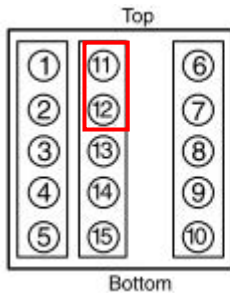

Terminal No.	Terminal name	Terminal No.	Terminal name	Terminal No.	Terminal name
1	CT1S	11	RS-485 B (+)	6	P1 Voltage
2	CT1L	12	RS-485 A (-)	7	P2 Voltage
3	CT3S	13	OUT1	8	P3 Voltage
4	CT3L	14	I/O common	9	NC
5	Event Input 2	15	Event Input 1	10	NC

■ Cable/Pin assignment

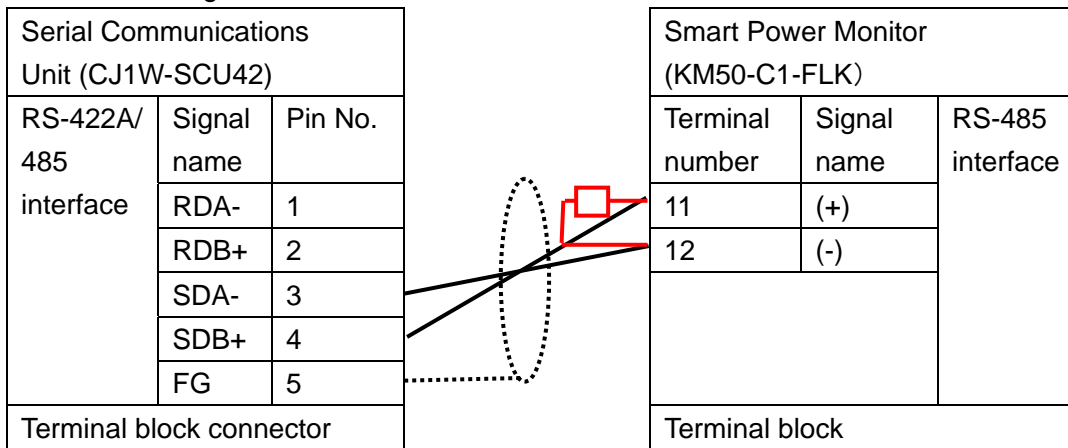

Precautions for Correct Use

Turn ON the terminating resistance switch on the Serial Communications Unit and connect a terminating resistor of 120Ω (1/2W) to the Smart Power Monitor mounted at the end of the network as shown in the pin assignment above.

6.3. Example of Connection Check

This document shows an example of a ladder program and protocol macro data in which the PLC sends/receives the message to/from the Smart Power Monitor.

The PLC and Smart Power Monitor send and receive the message of Unit Properties Read (Sequence No. 618). The following figure outlines the sequence operation.

*The Unit Properties Read command is provided with the CompoWay/F standard system protocol in the CX-Protocol.

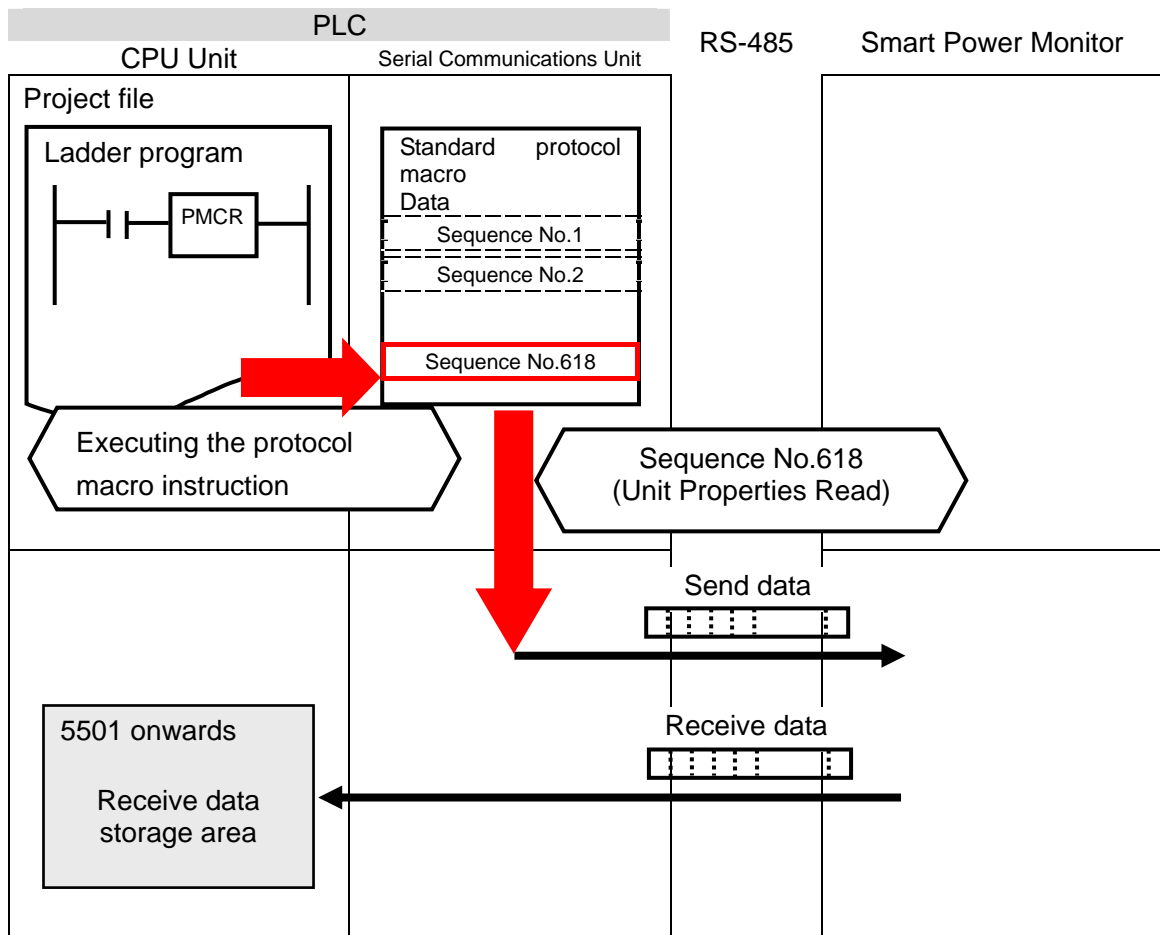

7. Connection Procedure

This section describes the procedure for connecting the Smart Power Monitor to the PLC via serial communications.

This document explains the procedure for setting up the PLC and the Smart Power Monitor from the factory default setting. For the initialization, refer to *Section 8 Initialization Method*.

7.1. Work Flow

Take the following steps to connect the Smart Power Monitor to the PLC via serial communications.

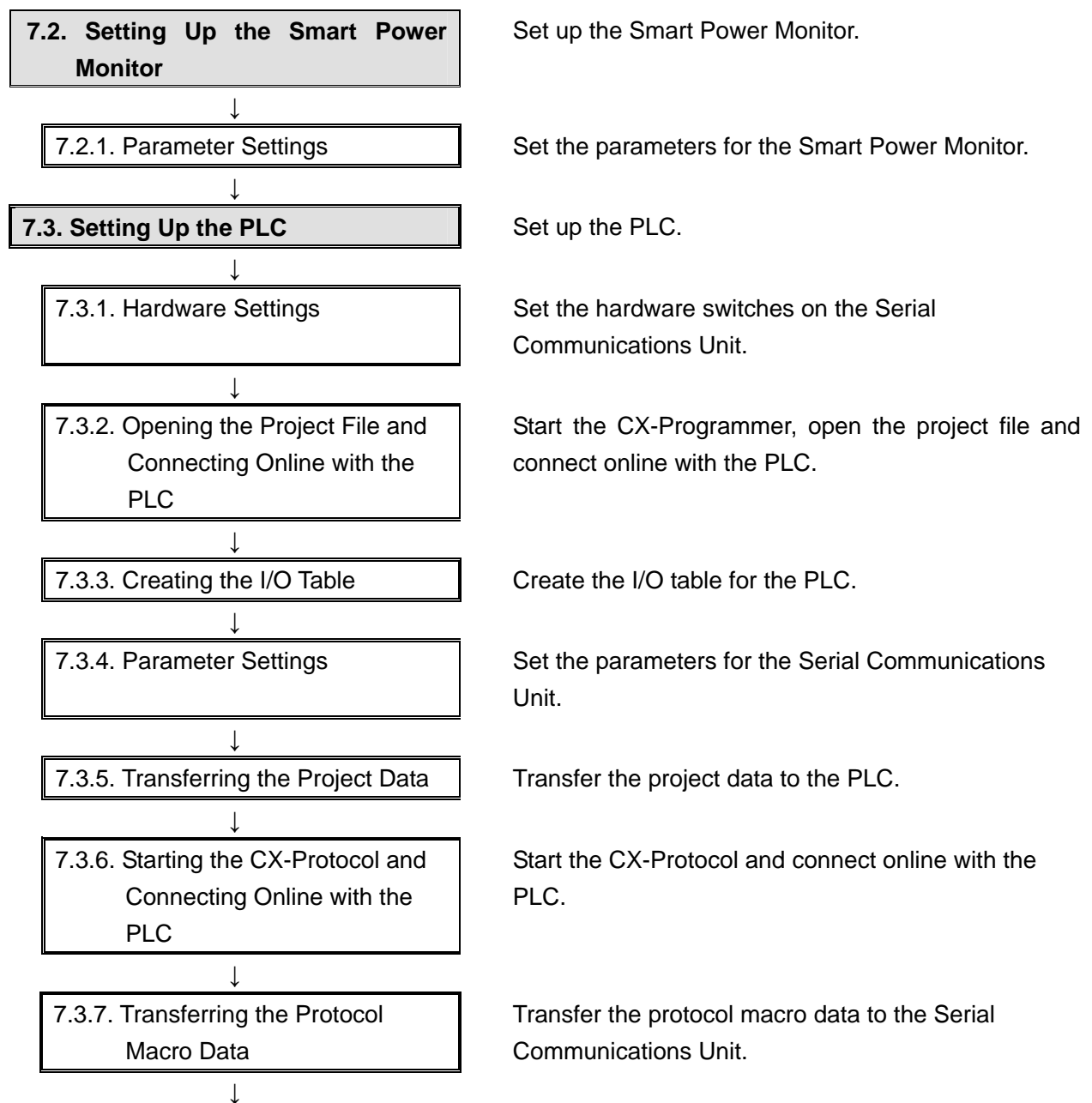

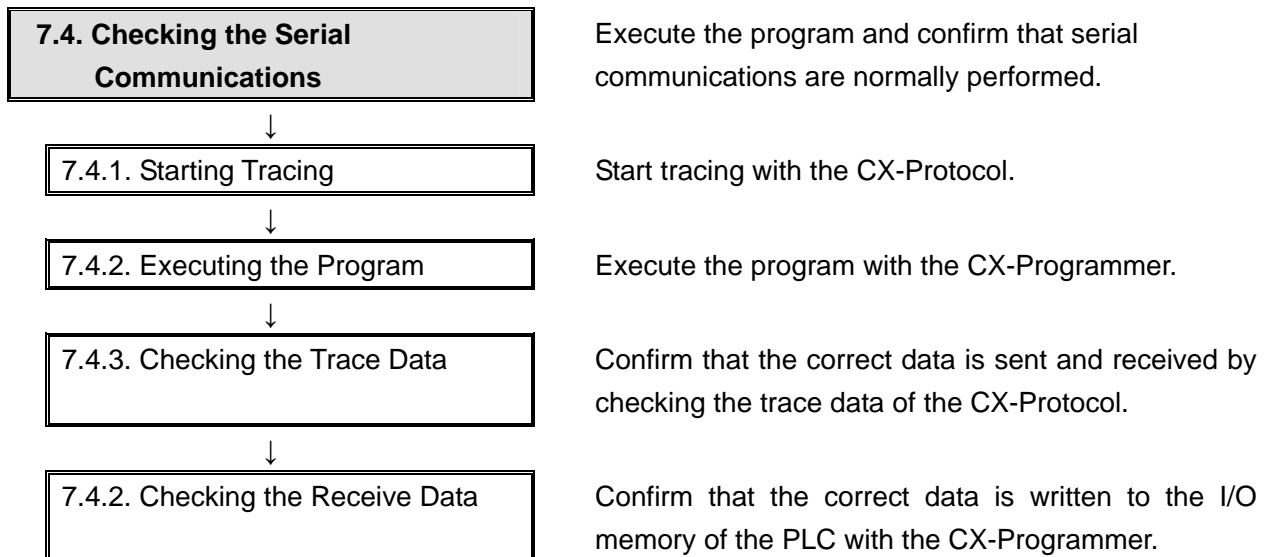

7.2. Setting Up the Smart Power Monitor

Set up the Smart Power Monitor.

7.2.1. Parameter Settings

Set the parameters for the Smart Power Monitor.

- 1 Connect the 100 to 200 VAC power supply cable to terminals 9 and 10 (control power) of the Smart Power Monitor, and connect the serial cable to terminal 29 (RS485(+)) and terminal 30 (RS485(-)).

*To measure the power, wire cables by referring to the KM50-E Smart Power Monitor Instruction Manual (Cat. No. 9497231-5).

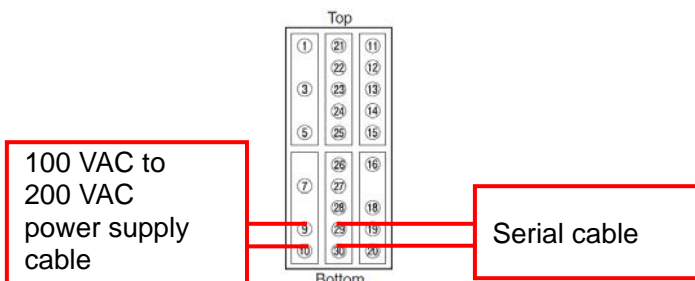

(Terminal block on the back of Smart Power Monitor)

- 2 Turn ON the power supply to the Smart Power Monitor.

*It takes approximately 3 seconds to complete the startup process.

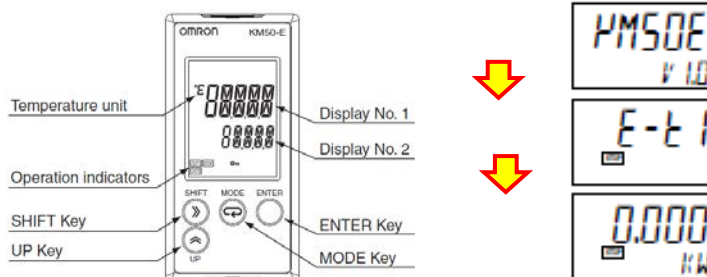

(Startup completed)

(Front of Smart Power Monitor)

(Display screen)

- 3 Switch from Measurement Mode to Operation Setting Mode by holding down the MODE () Key for at least 3 seconds.

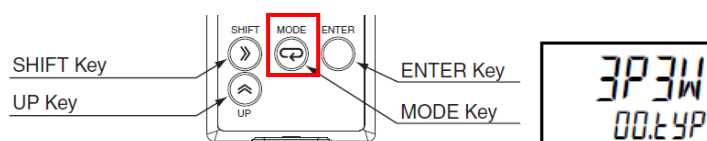

(Front of Monitor)

(Display screen)

- 4 Switch from Operation Setting Mode to Communications Setting Mode by pressing the ENTER () Key.

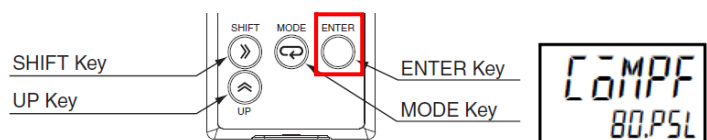

(Front of Monitor)

(Display screen)

5 Confirm that the communications settings are the default values by pressing the SHIFT (⇨) Key.

Protocol Selection: COMPF
(CompoWay/F)

Unit Number: 1

Baud Rate: 9.6k

Data Length: 7

Stop Bits: 2

Vertical Parity: EVEN

Transmission Wait Time: 20

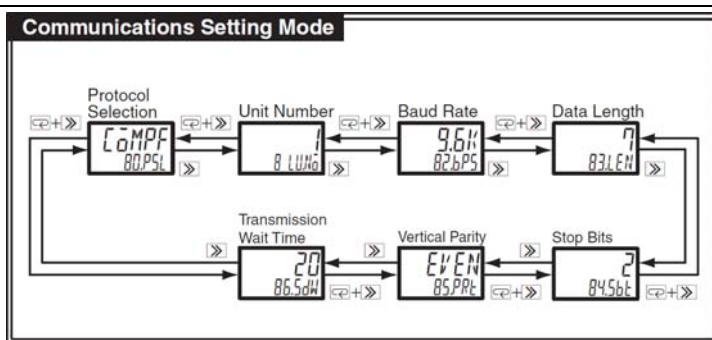

Parameter	Setting range (Display No. 1)	Display No. 2	Default setting	Remarks
Protocol Selection	COMPF / Modbus	MODBUS	COMPF	COMPF : CompoWay/F Modbus : Modbus
Unit Number	CompoWay/F: 0 to 99 Modbus: 1 to 99	1	1	
Baud Rate	1.2k / 2.4k / 4.8k / 9.6k / 19.2k / 38.4k	9.6k	9.6k	Unit: bps
Data Length *1	7 / 8	7	7	Unit: bits
Stop Bits *2	1 / 2	2	2	Unit: bits
Vertical Parity	None / odd / EVEN	EVEN	EVEN	
Transmission Wait Time	0 to 99	20	20	Unit: ms

*If the settings are different from the above, change the corresponding set values.

6 Hold down the MODE (⇩) Key for at least 3 seconds. SAVE is displayed and the settings are saved.

Then, the screen switches to Measurement Mode (Measurement start).

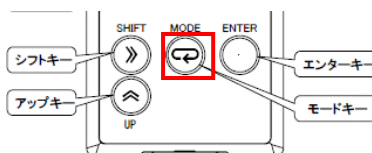

(Front of Monitor)

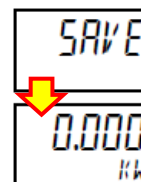

(Display screen)



Additional Information

Make communications settings for KM50-C1-FLK by using the same procedure as KM50-E1-FLK.

The appearance (locations of the monitor and each key) of KM50-C1-FLK is shown below.

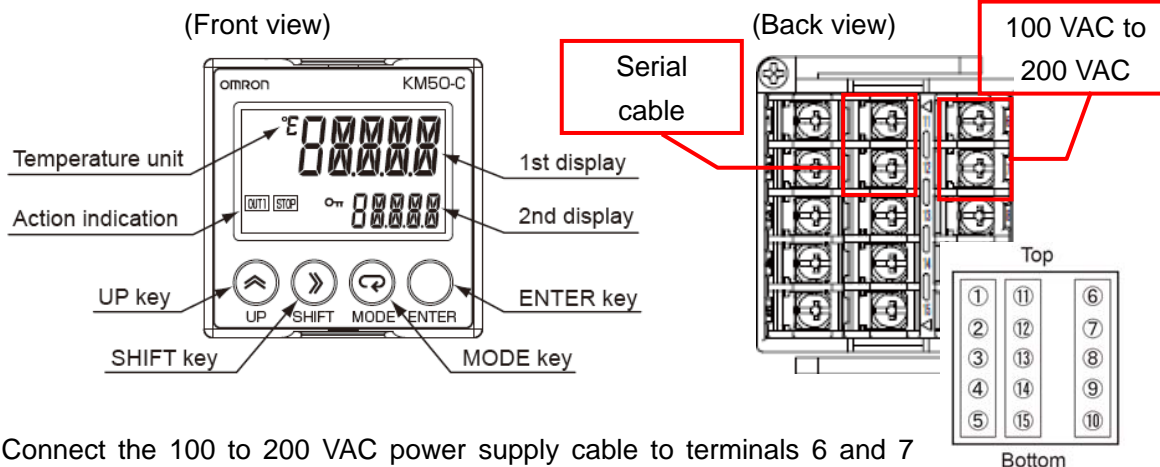

Connect the 100 to 200 VAC power supply cable to terminals 6 and 7 (power supply) of the Smart Power Monitor, and connect the serial cable to terminal 11 (RS485(+)) and terminal 12 (RS485(-)).

*To measure the power, you must wire cables additionally. Refer to the *KM50-C Smart Power Monitor Instruction Manual* (Cat. No. 9497202-1) and wire cables.

7.3. Setting Up the PLC

Set up the PLC.

7.3.1. Hardware Settings

Set the hardware switches on the Serial Communications Unit.



Precautions for Correct Use

Make sure that the power supply is OFF when you perform the setting up.

<p>1 Make sure that the power supply to the PLC is OFF.</p> <p>*If the power supply is turned ON, settings may not be applicable in the following procedure.</p> <p>Check the hardware switches located on the front panel of the Serial Communications Unit by referring to the right figure.</p> <p>Connect the serial cable (RS-485) to Port 1 connector.</p> <p>*This setting is required to use Port 1 of the Serial Communications Unit.</p>	
<p>2 Set the Unit No. Switch to 0. (The unit number is factory-set to 0.)</p>	
<p>3 Set the terminating resistance ON/OFF switch for port 1 to ON (terminating resistance ON).</p>	<p>TERM: Terminating resistance ON/OFF switch OFF: Terminating resistance OFF ON: Terminating resistance ON</p>
<p>4 Set the 2-wire or 4-wire selector switch for port 1 to 2 (2-wire).</p>	<p>WIRE: 2-wire or 4-wire selector switch 2-wire; 4: 4-wire</p>

7.3.2. Opening the Project File and Connecting Online with the PLC

Start the CX-Programmer, open the project file, and connect online with the PLC.

Install the CX-Programmer and USB driver in the personal computer beforehand.

- 1 Confirm that the personal computer and PLC are connected with the USB cable and turn ON the power supply to the PLC.

Start the CX-Programmer.

*If a confirmation dialog for an access right is displayed at start, select to start.

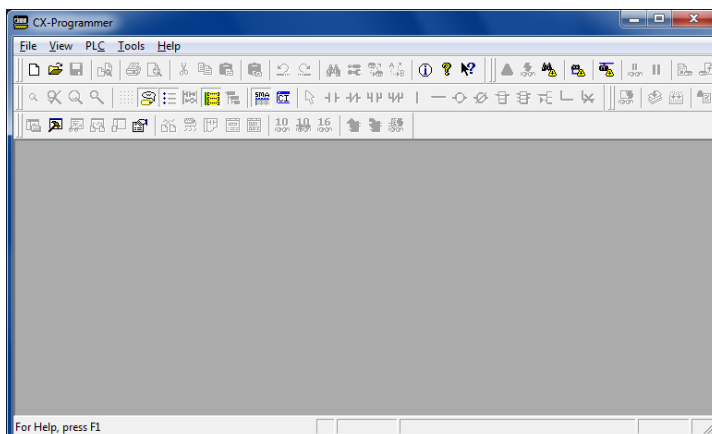

- 2 Select **Open** from the File Menu.

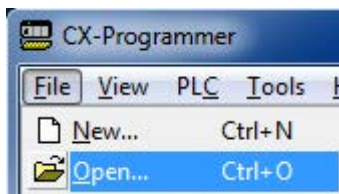

- 3 On the Open CX-Programmer Project Dialog Box, select the OMRON_KM50_PMCR485_EV1_00.cxp and click the **Open** Button.

*Obtain the project file from OMRON.

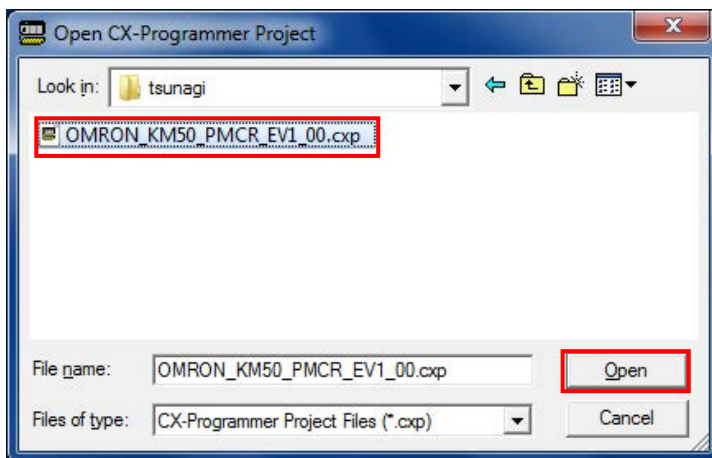

- 4 After opening the project file, select **Programs** in the project workspace.

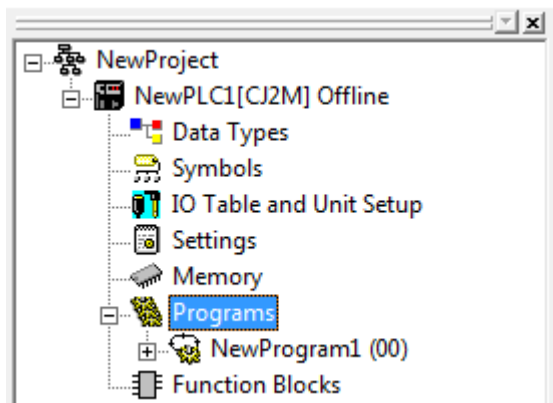

(Project workspace)

5 Select **Change Model** from the PLC Menu.

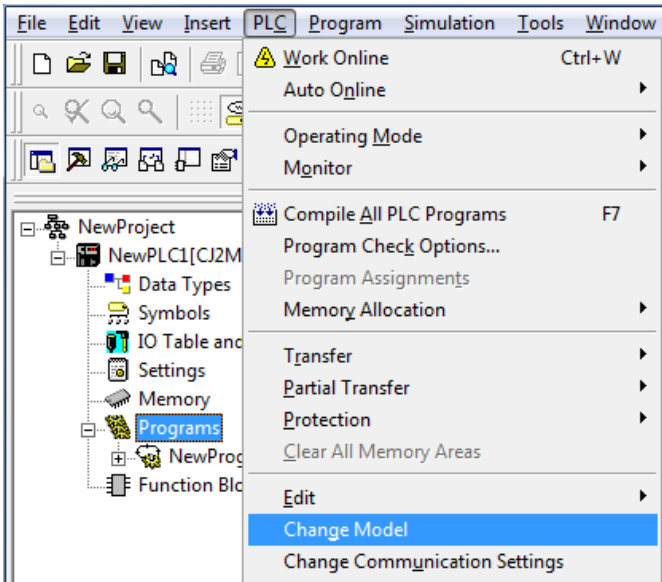

6 The Change PLC Dialog Box is displayed. Select a device type to use from the pull-down list of the Device Type, and click the **Settings** Button.

*CJ2M is selected in this document.

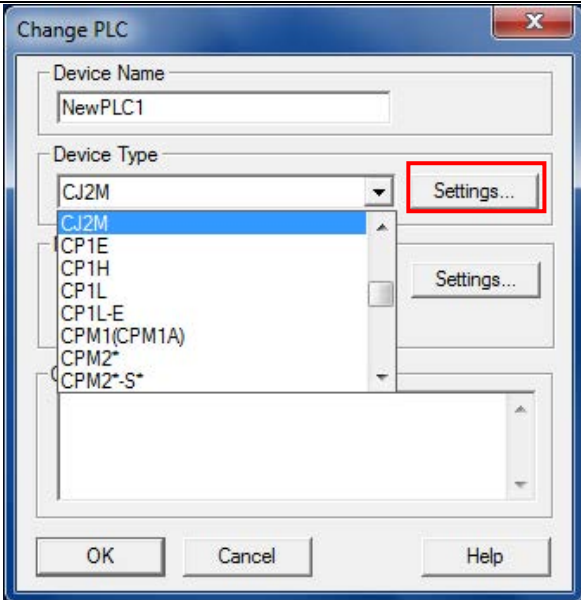

7 The Device Type Settings Dialog Box is displayed. Select a CPU type to use from the pull-down list of the CPU Type, and click the **OK** Button.

*CPU12 is selected in this document.

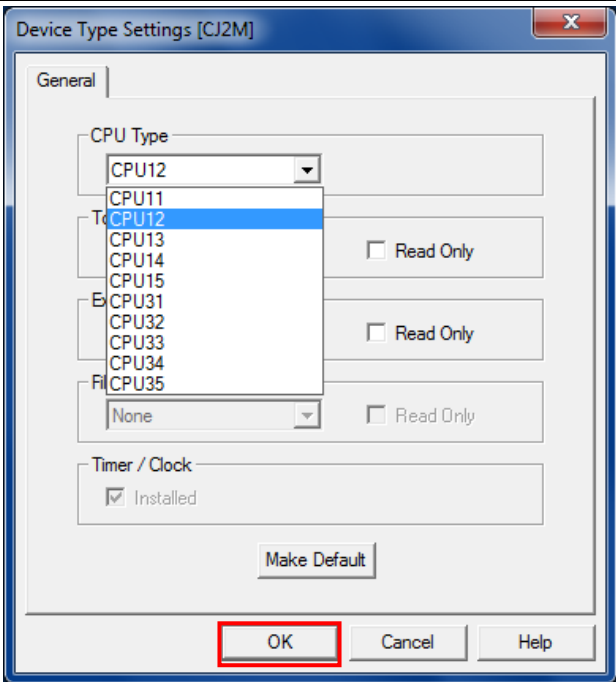



8 Confirm that the Network Type is set to USB on the Change PLC Dialog Box and click the **OK** Button.

*If the Network Type is not set to USB, select *USB* from the pull-down list.

*If you changed the Device Type in step 6 or the CPU Type in step 7, the dialog box on the right is displayed. Click the **Yes** Button.

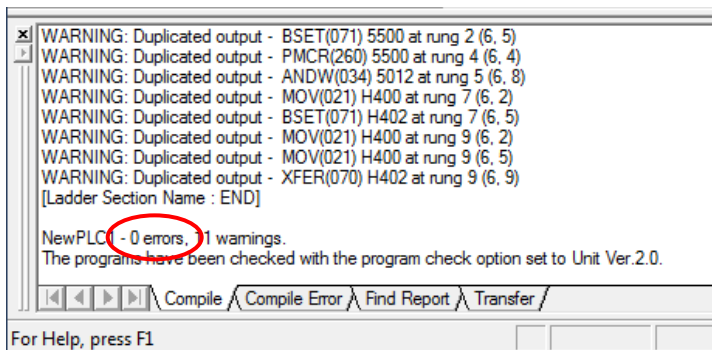
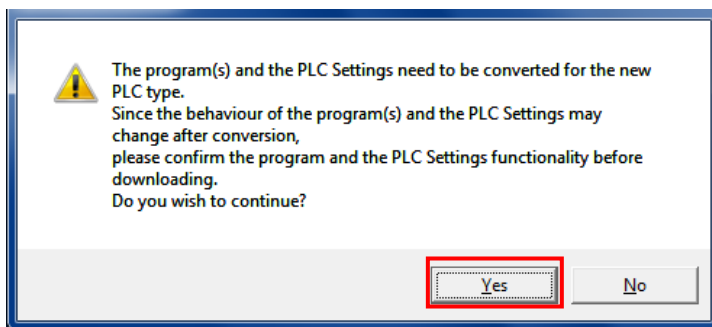
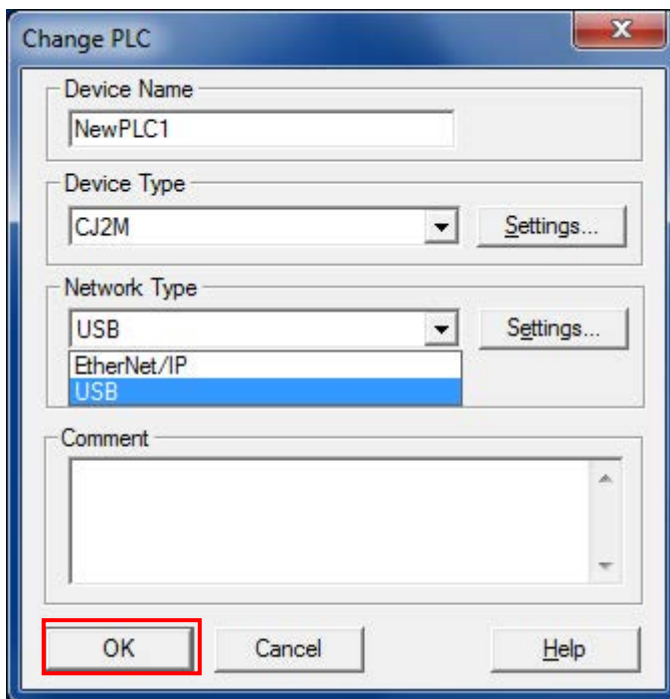
Confirm that the program was normally converted ("0 errors" must be shown).
(Although duplicated output warnings were detected in the right dialog, they are not problems.)

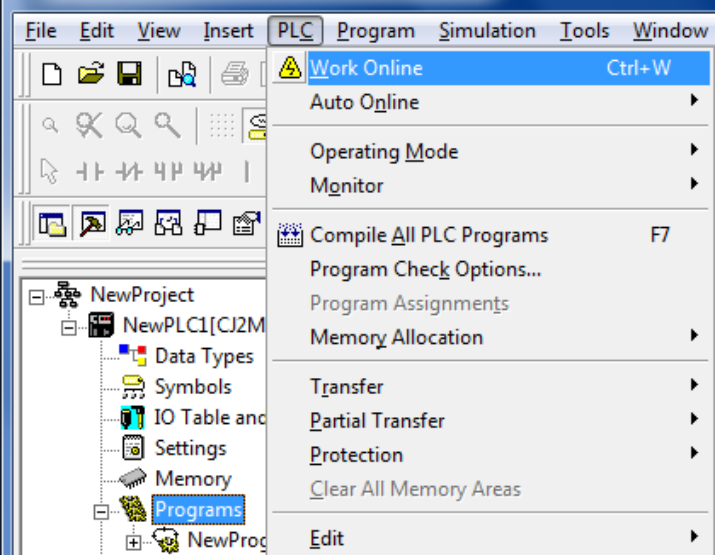
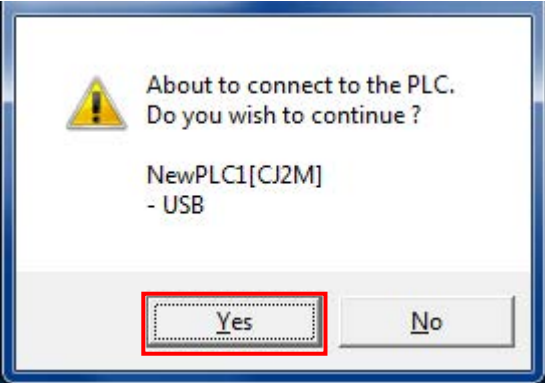
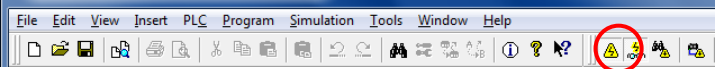

- 9** Select **Programs** in the project workspace and select **Work Online** from the PLC Menu.
- 
- 10** The dialog box on the right is displayed. Click the **Yes** Button.
- 
- 11** Confirm that the CX-Programmer and the PLC are normally connected online.
- 
- *The icon  is shown during online connection.



Additional Information

If the CX-Programmer and PLC are not connected online, please check the connection of the cable. Or, return to step 5, check the settings in steps 6 to 8 and try to connect them again. Refer to *Connecting Directly to a CJ2 CPU Unit Using a USB Cable* in *Chapter 3 Communications* in *PART 3: CX-Server Runtime* of the *CX-Programmer Operation Manual* (Cat. No. W466) for details.



Additional Information

The dialogs explained in this document may not be displayed depending on the environmental setting of CX-Programmer. For details on the environmental setting, refer to *Options and Preferences* in *Chapter 3 Project Reference* in *PART 1: CX-Programmer* of the *CX-Programmer Operation Manual* (Cat. No. W466).

This document explains the setting procedure when the Confirm all operations affecting the PLC Check Box is selected.

7.3.3. Creating the I/O Table

Create the I/O table for the PLC.

1 If the operating mode of the PLC is RUN Mode or Monitor Mode, change it to Program Mode by following the steps below.

(1) Select **Operating Mode - Program** from the PLC Menu of the CX-Programmer.

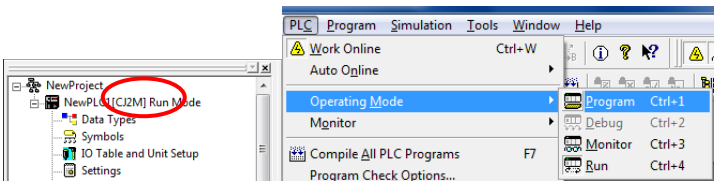

(2) The dialog box on the right is displayed. Click the **Yes** Button.

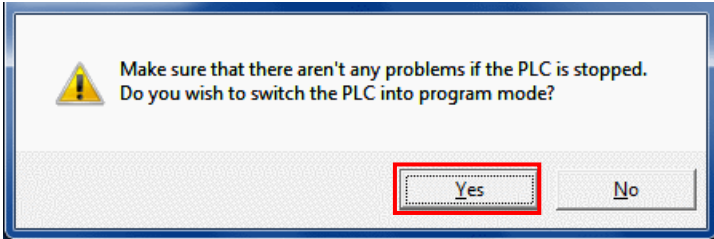

*Please refer to *Additional Information* on the previous page for the settings concerning the dialog display.

(3) Confirm that Stop/Program Mode is displayed on the right of the PLC model in the Project Tree.

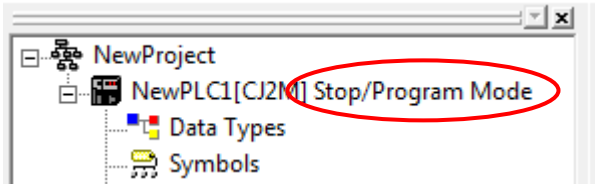

2 Select **Edit - I/O Table and Unit Setup** from the PLC Menu of the CX-Programmer.

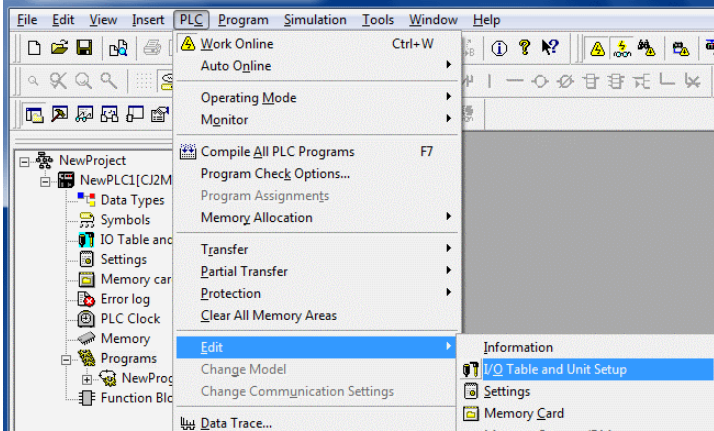

The PLC IO Table Window is displayed.

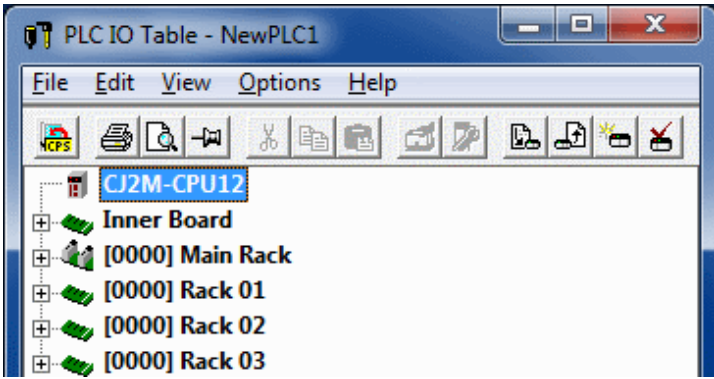

3 Select **Create** from the Options Menu of the PLC IO Table Window.

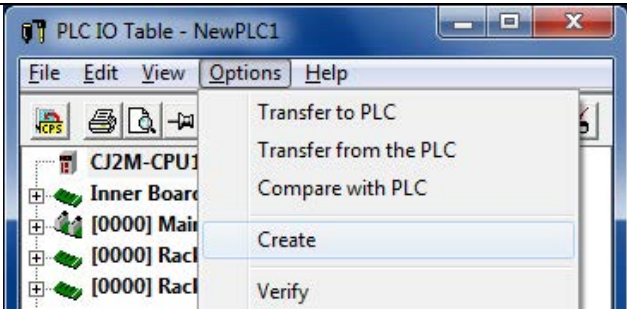

The dialog box on the right is displayed. Click the **Yes** Button.

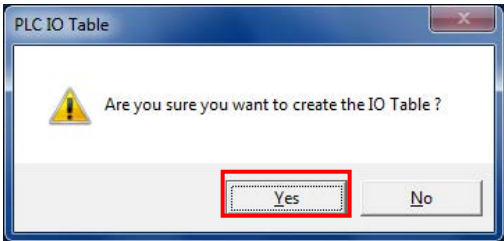

The dialog box on the right is displayed. Click the **Yes** Button.

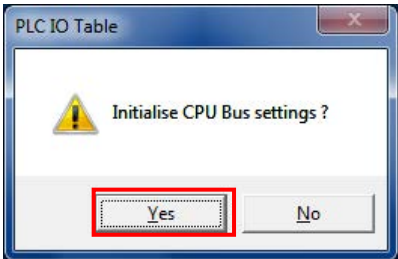

4 The Transfer from PLC Dialog Box is displayed. Select the *I/O Table* Check Box and the *SIO Unit Parameters* Check Box, and click the **Transfer** Button.

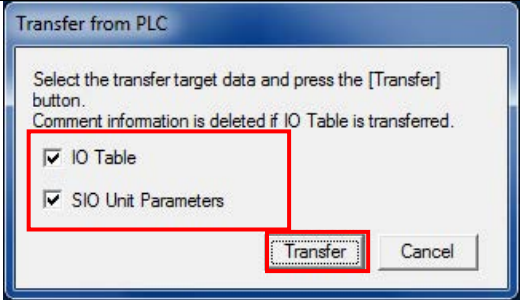

When the transfer is completed, the Transfer Results Dialog Box is displayed.

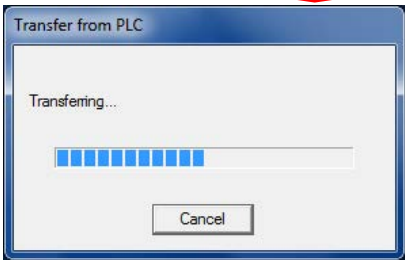

Confirm that the transfer was normally executed by referring to the message in the dialog box.

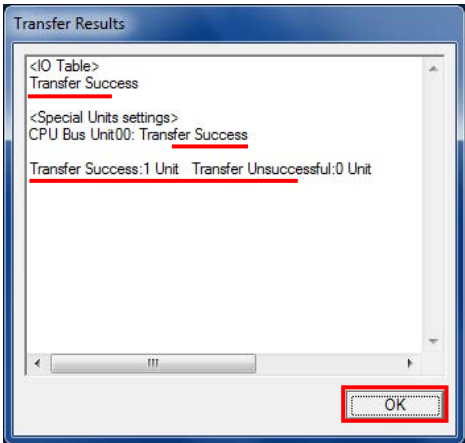

When the I/O table is created normally, the dialog box shows the following,
Transfer Success: 1 Unit
Transfer Unsuccessful: 0 Unit

Click the **OK** Button.

7.3.4. Parameter Settings

Set the parameters for the Serial Communications Unit.

- 1 Double-click [0000] Main Rack on the PLC IO Table Window to expand the tree.

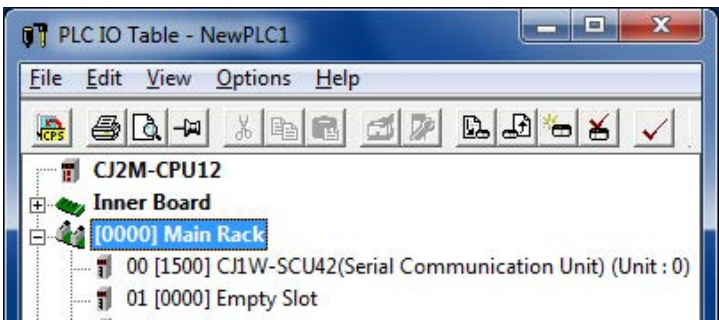

- 2 Right-click 00[1500]CJ1W-SCU42 and select the Unit Setup.

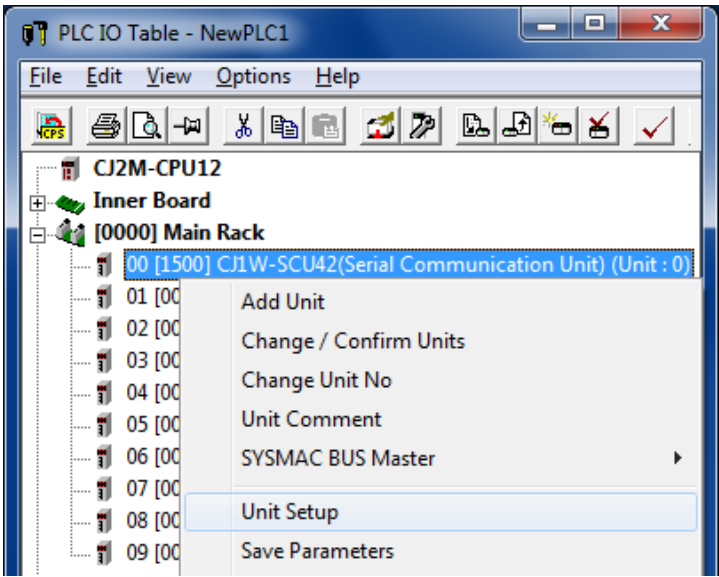

- 3 The View Parameters Dialog Box is displayed. Select Port1: Protocol macro Settings for Displayed Parameter.

*This setting is required to use Port 1 of the Serial Communications Unit.

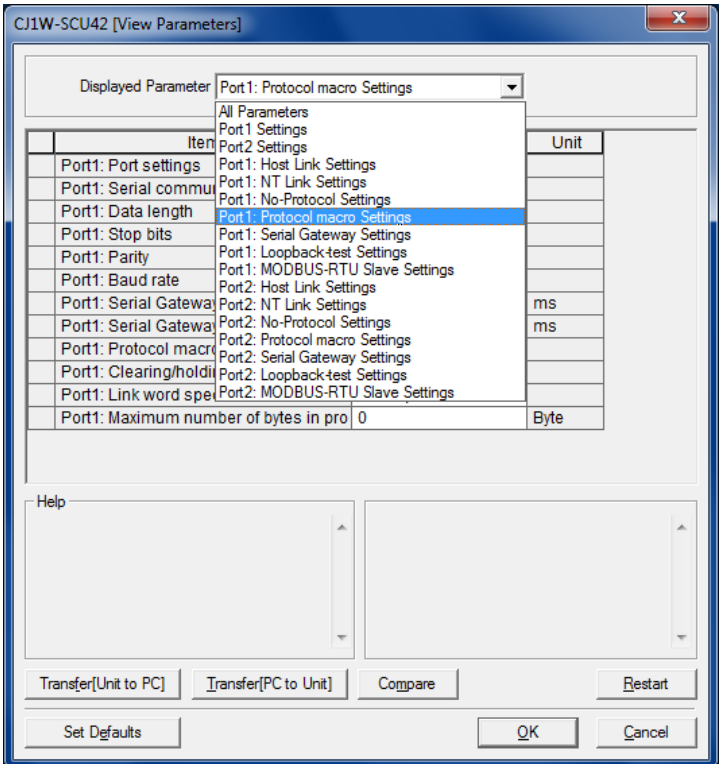

4 The setting items of Port 1: Protocol macro Settings are listed as shown in the right figure. (The figure shows the default values.)

CJ1W-SCU42 [View Parameters]

Displayed Parameter: Port 1: Protocol macro Settings

Item	Set Value	Unit
Port1: Port settings	Defaults	
Port1: Serial communications mode	Host Link(default)	
Port1: Data length	7 bits	
Port1: Stop bits	2 bits	
Port1: Parity	Even	
Port1: Baud rate	Default(9600bps)	
Port1: Serial Gateway Response timeo	0	ms
Port1: Serial Gateway send start timeo	0	ms
Port1: Protocol macro Transmission m	Half-duplex	
Port1: Clearing/holding the contents of	Clear	
Port1: Link word specification data exc	On-request I/O refre	
Port1: Maximum number of bytes in pro	0	Byte

5 Select *User settings* for Port settings.

CJ1W-SCU42 [View Parameters]

Displayed Parameter: Port 1: Protocol macro Settings

Item	Set Value	Unit
Port1: Port settings	Defaults	
Port1: Serial communications mode	Defaults	
Port1: Data length	User settings	
Port1: Stop bits	2 bits	
Port1: Parity	Even	
Port1: Baud rate	Default(9600bps)	
Port1: Serial Gateway Response timeo	0	ms
Port1: Serial Gateway send start timeo	0	ms
Port1: Protocol macro Transmission m	Half-duplex	
Port1: Clearing/holding the contents of	Clear	
Port1: Link word specification data exc	On-request I/O refre	
Port1: Maximum number of bytes in pro	0	Byte

6 Set the following parameters in the same way as step 5.

- Serial Communications Mode: Protocol macro
- Data length : 7 bits
- Stop bit : 2 bits
- Parity : Even
- Baud rate : Default (9600 bps)
- Protocol macro Transmission method: Half-duplex

*Use the default settings for other parameters.

Click the **Transfer[PC to Unit]** Button.

CJ1W-SCU42 [View Parameters]

Displayed Parameter: Port 1: Protocol macro Settings

Item	Set Value	Unit
Port1: Port settings	User settings	
Port1: Serial communications mode	Protocol macro	
Port1: Data length	7 bits	
Port1: Stop bits	2 bits	
Port1: Parity	Even	
Port1: Baud rate	Default(9600bps)	
Port1: Serial Gateway Response timeo	0	ms
Port1: Serial Gateway send start timeo	0	ms
Port1: Protocol macro Transmission m	Half-duplex	
Port1: Clearing/holding the contents of	Clear	
Port1: Link word specification data exc	On-request I/O refre	
Port1: Maximum number of bytes in pro	0	Byte

Help: <Default>Host Link(default)
<Address>Word:D30000, Bit:8-11
<Type>List

Transfer[Unit to PC] **Transfer[PC to Unit]** Compare Restart

Set Defaults OK Cancel

7 The dialog box on the right is displayed. Click the **Yes** Button.

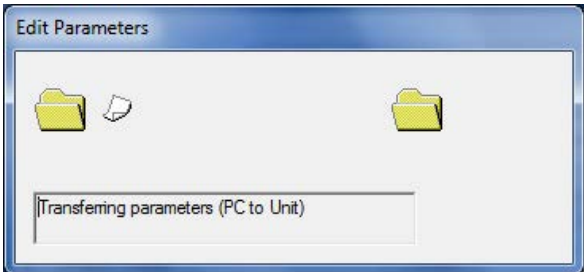
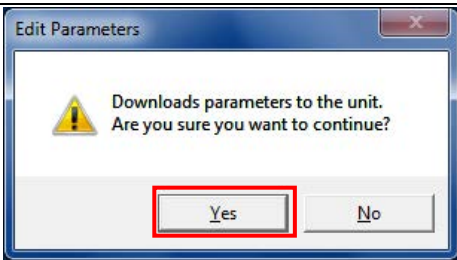

When the transfer is completed, the dialog box on the right is displayed. Click the **Close** Button.

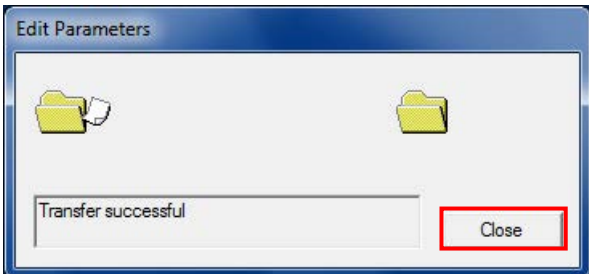

8 The dialog box on the right is displayed. Click the **Yes** Button.

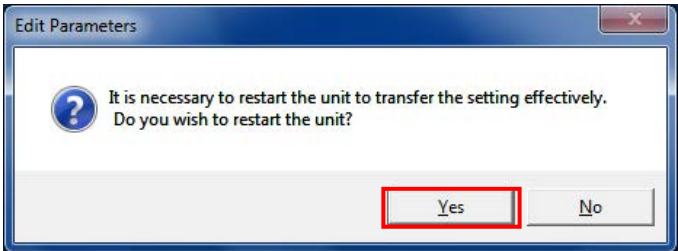

The Select Port Dialog Box is displayed. Select *All ports* and click the **OK** Button.

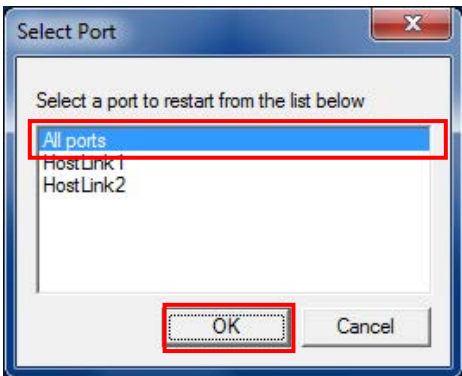

9 The dialog box on the right is displayed. Click the **OK** Button.

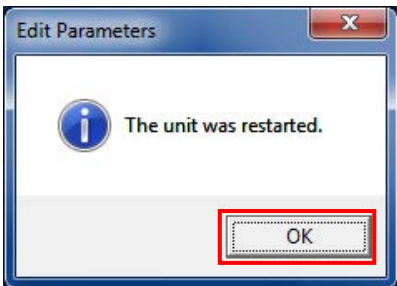

10 Click the **Compare** Button on the View Parameters Dialog Box.

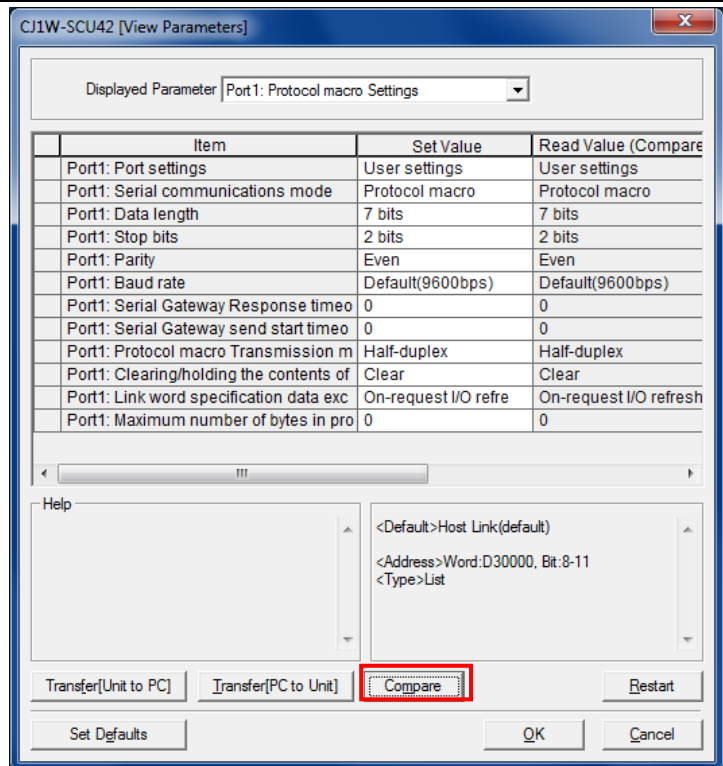

11 The dialog box on the right is displayed when the parameter settings matches. Click the **Close** Button.

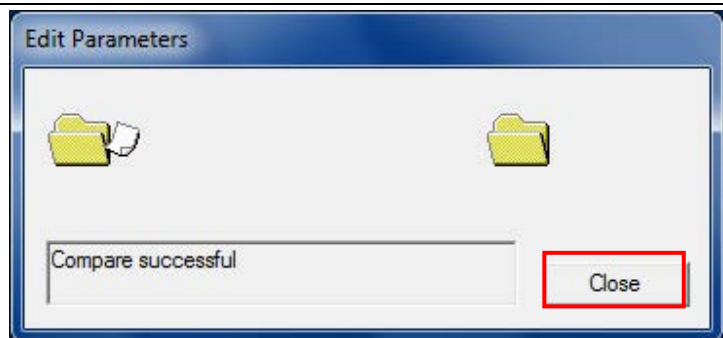

12 Click the **OK** Button on the View Parameters Dialog Box.

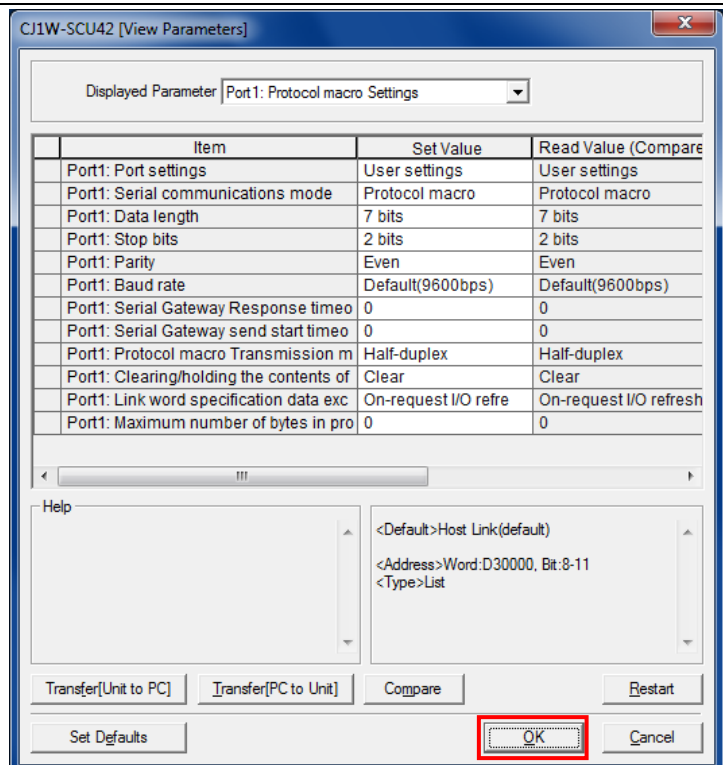

7.3.5. Transferring Project Data

Transfer the project data to the PLC.

1 Select **Programs** on the project workspace of the CX-programmer, and select **Transfer - To PLC** from the PLC Menu.

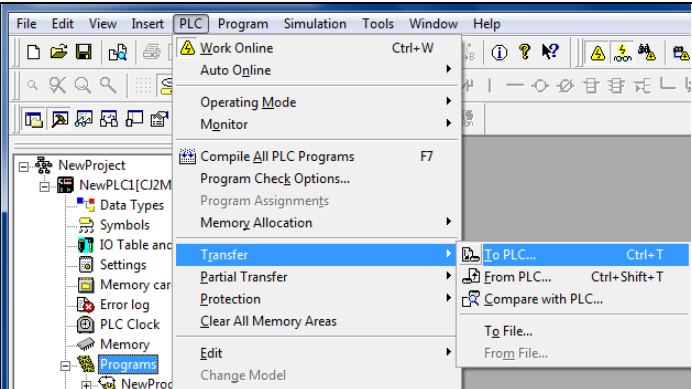

2 Select the *Program(s)* Check Box, *Comments* Check Box, and *Program index* Check Box, and click the **OK** Button.

*Transferring the I/O table and Special Unit Setup is unnecessary here, because they were set in Section 7.3.3 and Section 7.3.4.

*The Comments Check Box and the Program index Check Box may not be displayed depending on the device type. In such a case, select the *Program(s)* Check Box only and transfer the project data.

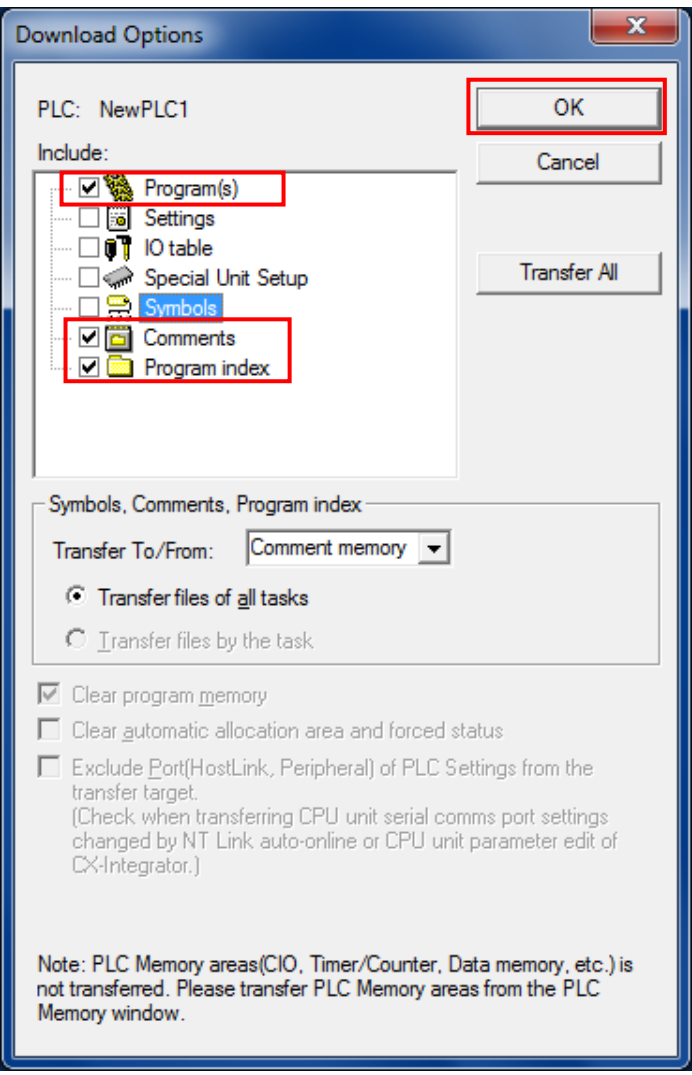

3 The dialog box on the right is displayed. Click the **Yes** Button.

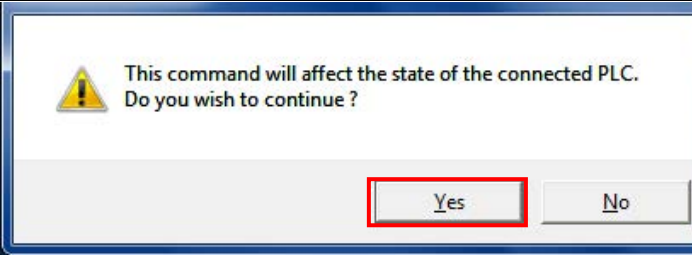

4 The dialog box on the right is displayed (stating "Download successful") when the transfer is completed. Click the **OK** Button.

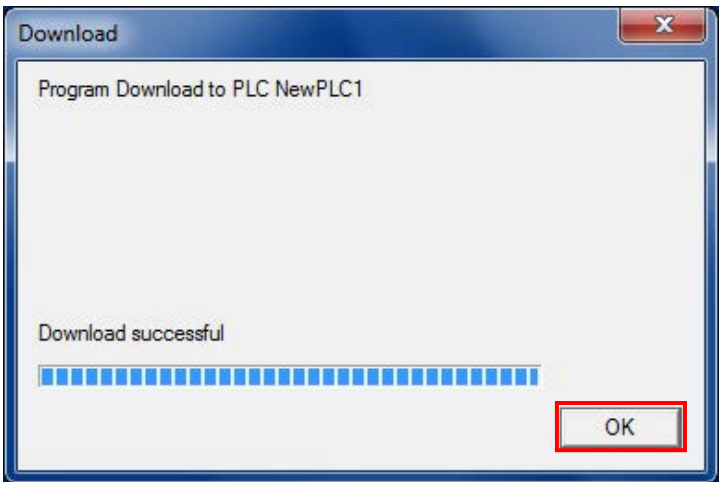

5 Select **Programs** in the project workspace, and select **Transfer - Compare with PLC** from the PLC Menu.

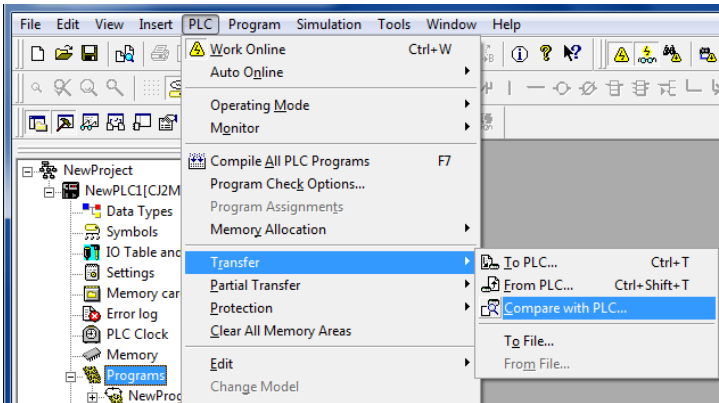

6 Select the **Program(s)** Check Box and click the **OK** Button.

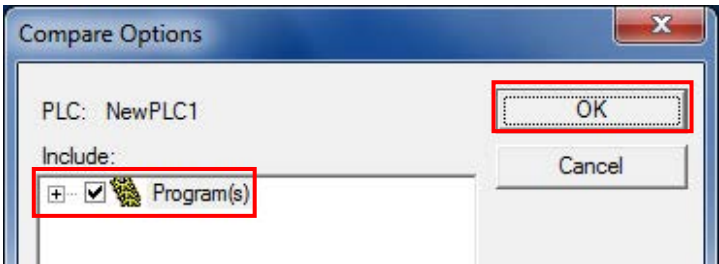

7 Confirm that a message stating "Compare successful" is displayed, and click the **OK** Button.

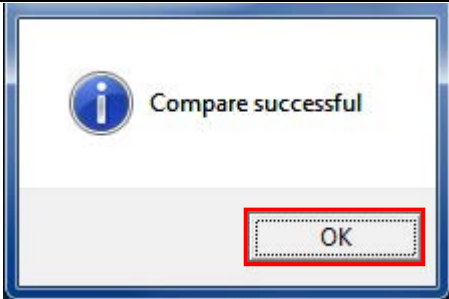

7.3.6. Starting the CX-Protocol and Connecting Online

Start the CX-Protocol and connect online with the PLC.

1 Start the CX-Protocol.

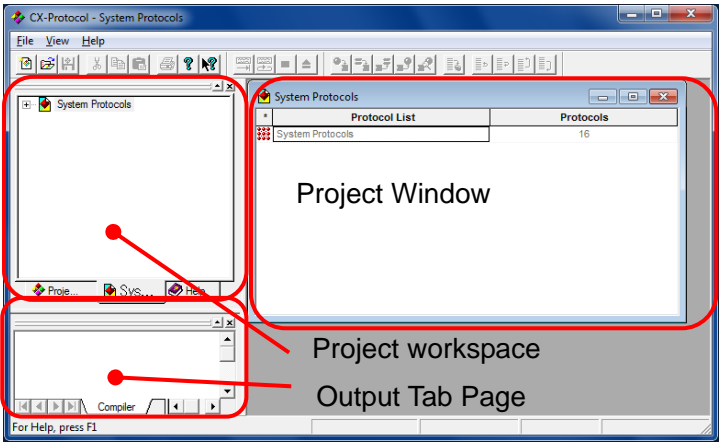

(CX-Protocol)

2 Select **Open** from the File Menu.

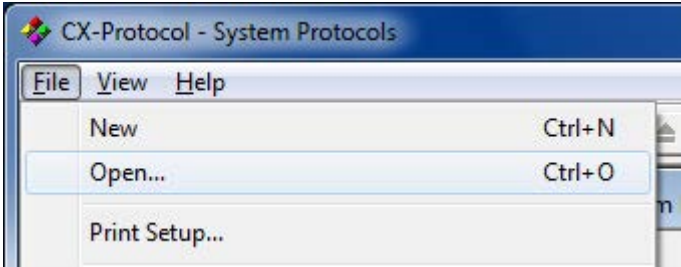

3 On the Open Dialog Box, select OMRON_KM50_PMCR_EV1_00.psw and click the **Open** Button.

*Obtain the protocol macro data from OMRON.

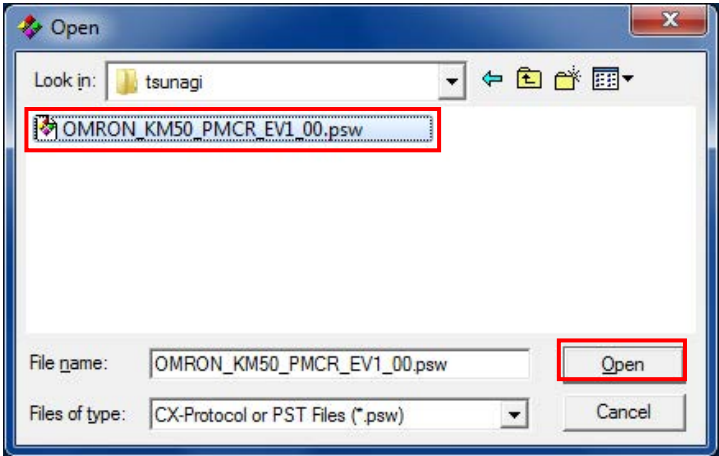

4 The project workspace and the Project Window display the protocol macro data that was read.

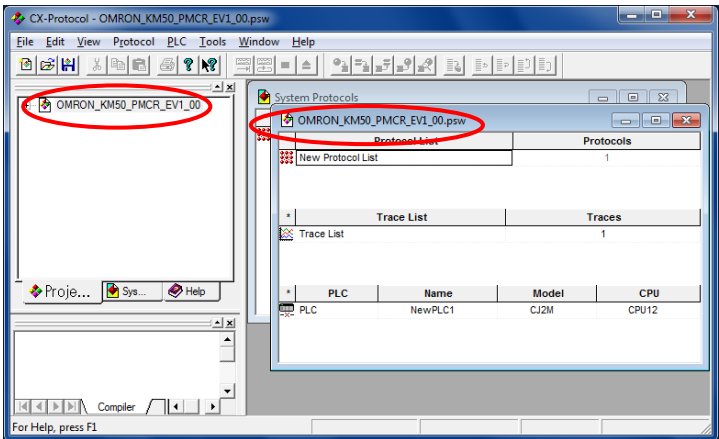

5 Double-click the OMRON_KM50_PMCR_EV1_00 on the project workspace to display a tree.

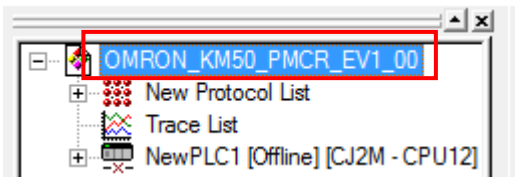

6 Select **Edit PC-PLC Comms Settings** from the PLC Menu.

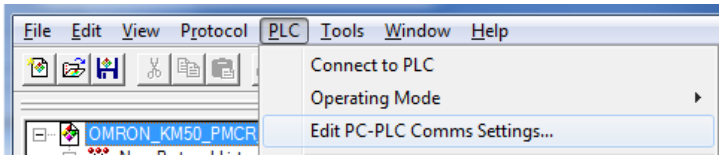

7 The Change PLC Dialog Box is displayed. Select a device type to use from the pull-down list of the Device Type, and click the **Settings** Button.

*CJ2M is used in this document.

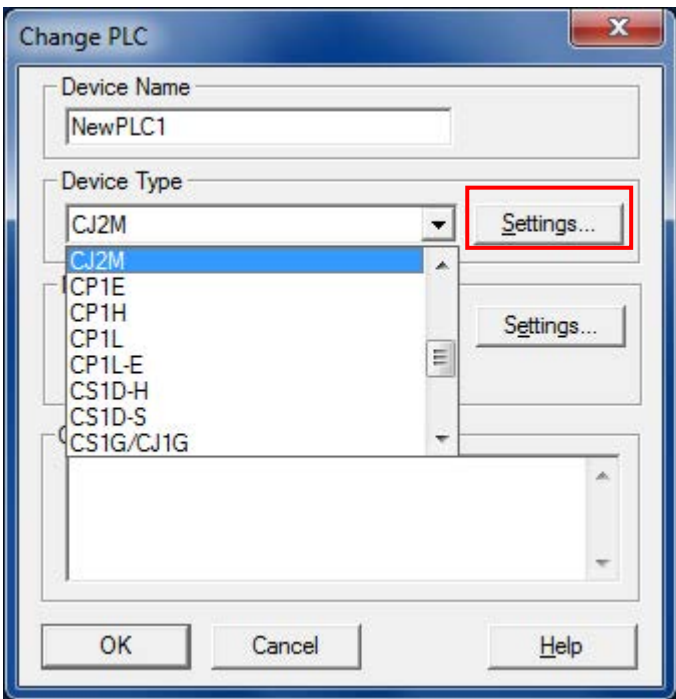

8 The Device Type Settings Dialog Box is displayed. Select a CPU type to use from the pull-down list of the CPU Type, and click the **OK** Button.

*CPU12 is used in this document.

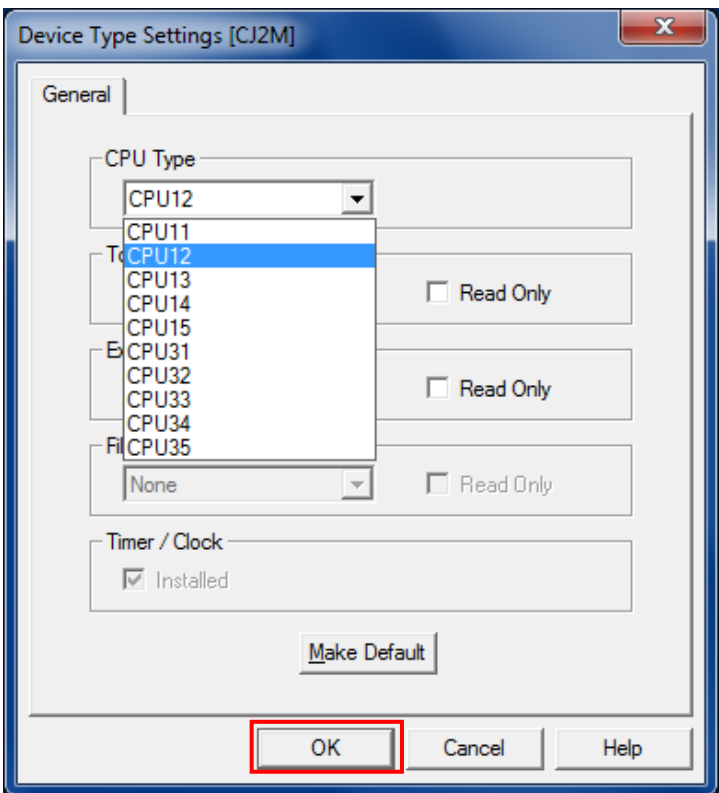

9 Confirm that the Network Type is set to USB on the Change PLC Dialog Box and click the **OK** Button.

*If the Network Type is not set to USB, select *USB* from the pull-down list.

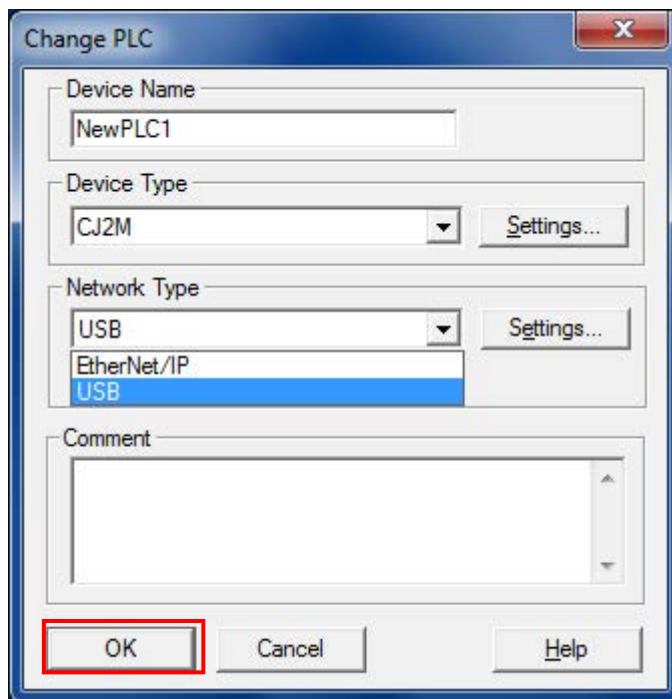

10 Select **Connect to PLC** from the PLC Menu.

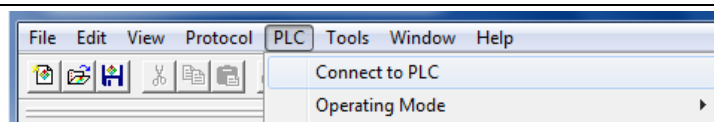

11 The PLC icon on the project workspace changes from Offline to Program. It means that the PLC is connected online.

*If Monitor or Run is displayed, change it to Program by following steps 12 and 13.

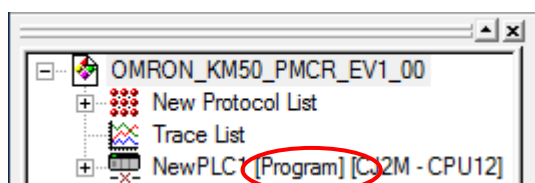

12 If the operating mode of the PLC is Monitor or Run, select **Operating Mode - Program** from the PLC Menu.

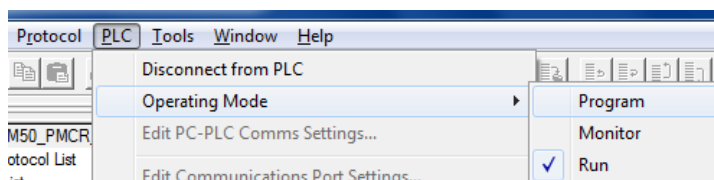

13 The dialog box on the right is displayed. Click the **Yes** Button. Confirm that the operating mode was changed to Program mode as shown in step 11.

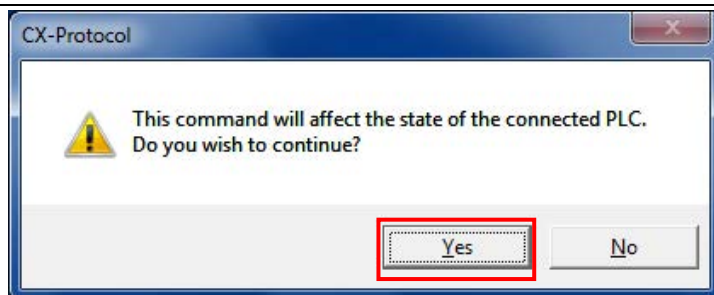

7.3.7. Transferring the Protocol Macro Data

Transfer the protocol macro data to the Serial Communications Unit.

- 1** Double-click the **New Protocol List** on the project workspace to display a tree.

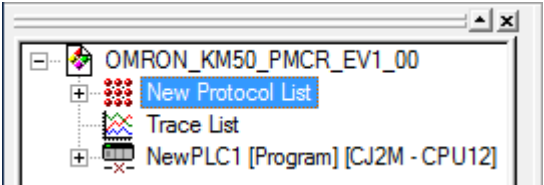
- 2** The Project Window on the right is displayed. Confirm that SCU[0] is entered in the Target Column.

*If SCU[0] is not entered, select *SCU[0]* as shown on the right figure.

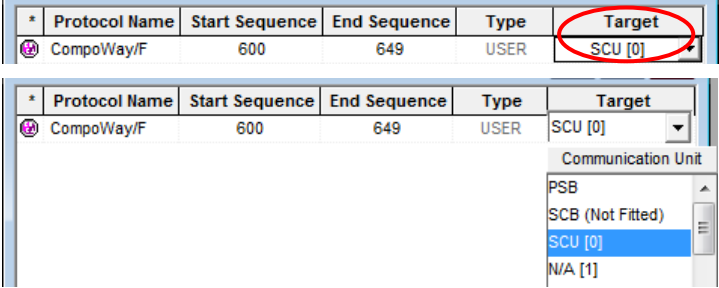

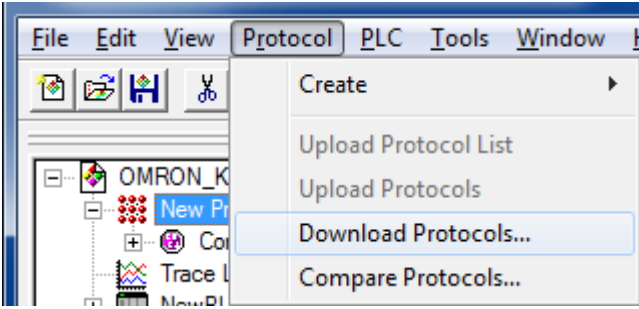
- 3** Select New Protocol List and select **Download Protocols** from the Protocol Menu.

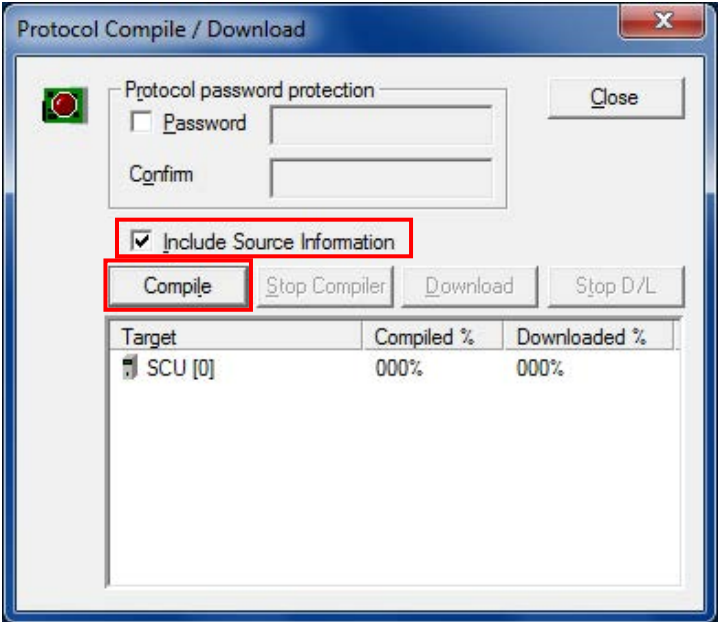
- 4** The dialog box on the right is displayed. Select the **Include Source Information** Check Box and click the **Compile** Button.

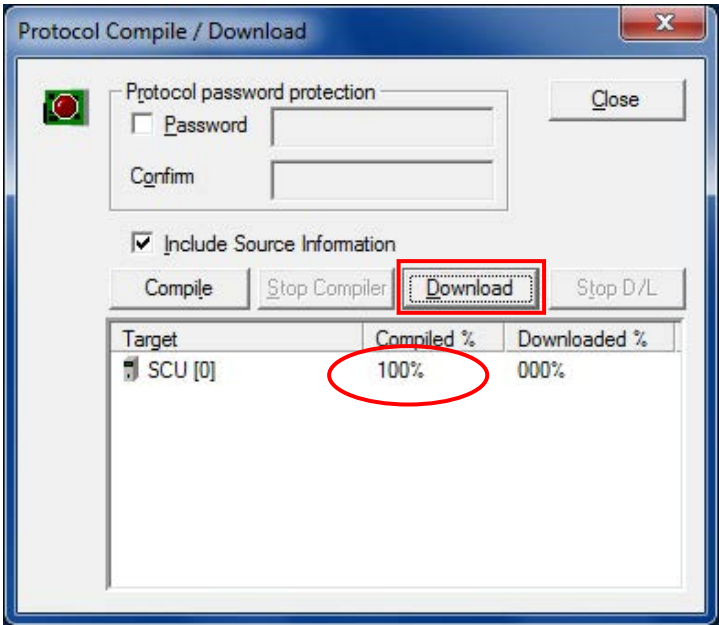

Target	Compiled %	Downloaded %
SCU [0]	000%	000%

5 When 100% is displayed in the Compiled % Column, the compiling operation is completed. After confirming that the compiling operation is completed, click the **Download** Button.



6 The dialog box on the right is displayed. Click the **OK** Button.

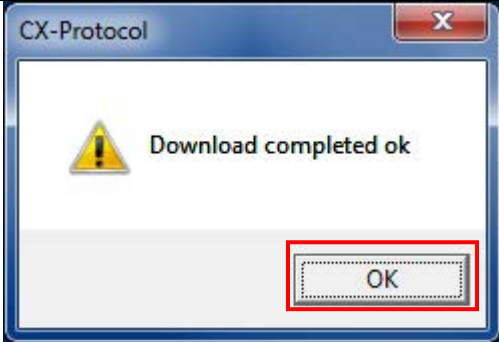

7 Check that 100% is displayed in the Downloaded % Column in the right figure, and click the **Close** Button.

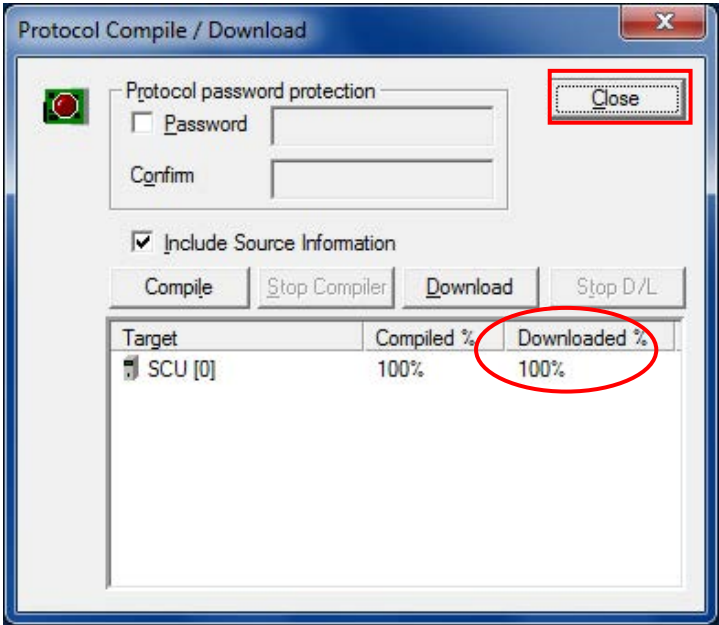

8 Select **Compare Protocols** from the Protocol Menu.

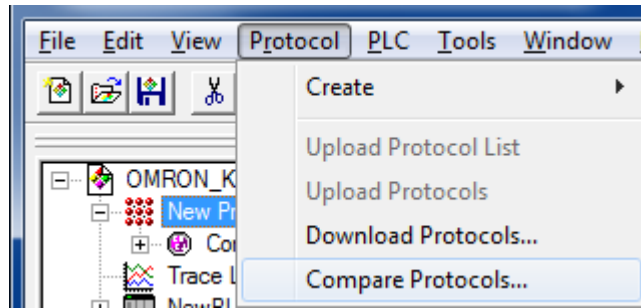

9 The dialog box on the right is displayed. Select the *Include Source Information* Check Box and click the **Compile** Button.

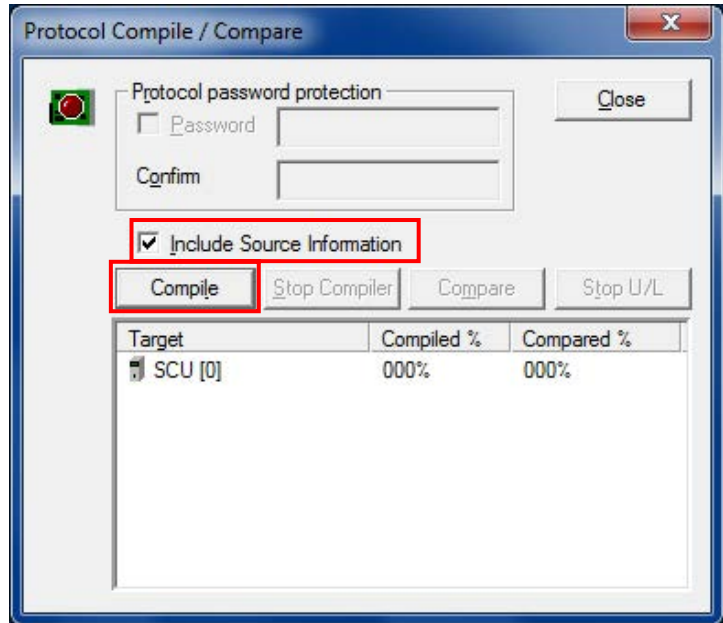

10 When 100% is displayed in the *Compiled %* Column, the compiling operation is completed. After confirming that the compiling operation is completed, click the **Compare** Button.

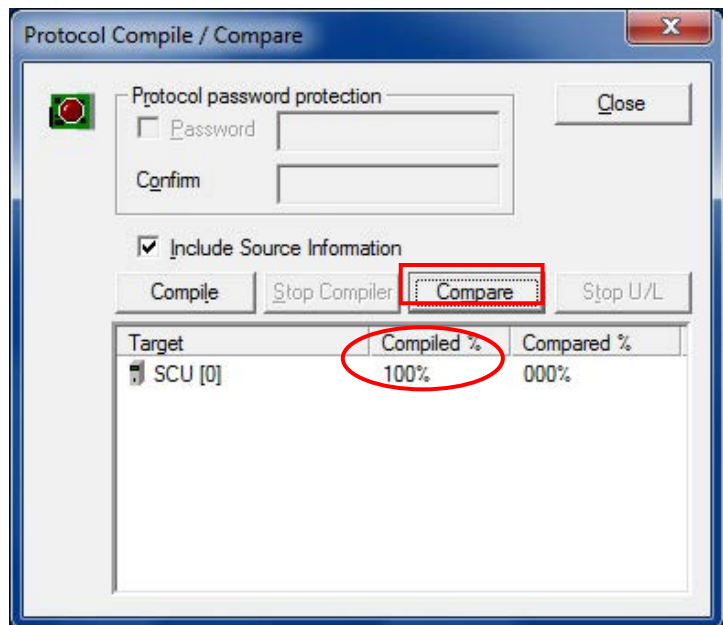

- 11** The dialog box on the right is displayed. Click the **OK** Button.

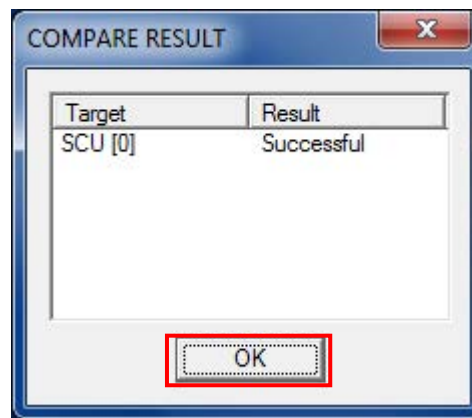

- 12** Confirm that 100% is displayed in the Compared % Column in the right figure, and click the **Close** Button.

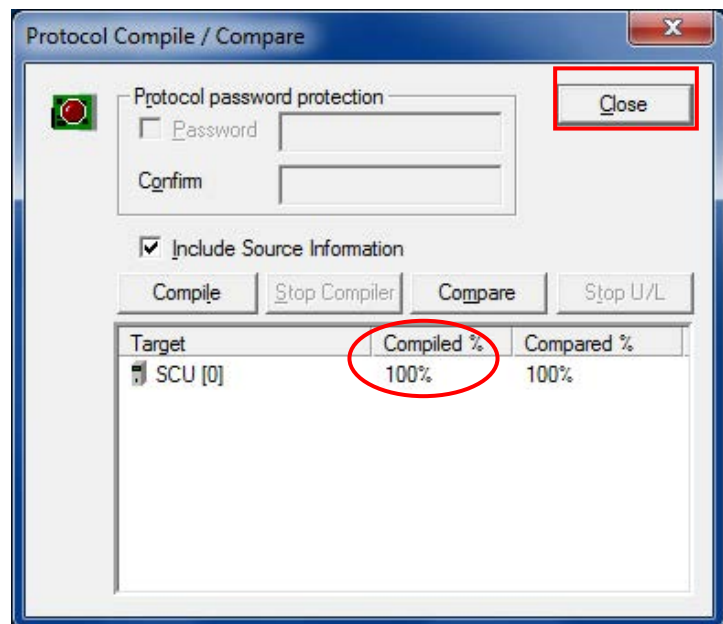

7.4. Checking the Serial Communications

Execute the program and confirm that serial communications are normally performed.

⚠ Caution

Confirm safety sufficiently before monitoring power flow and present value status in the Ladder Section window or before monitoring present values in the Watch window.

If force-set/reset or set/reset operations are incorrectly performed by pressing short-cut keys, the devices connected to Output Units may malfunction, regardless of the operating mode of the CPU Unit.



📌 Precautions for Correct Use

Confirm that the serial cable is connected before proceeding to the following procedure.

If it is not connected, turn OFF the power supply to each device, and then connect the serial cable.

7.4.1. Starting Tracing

Start tracing with the CX-Protocol.

<p>1 Select Operating Mode - Monitor from the PLC Menu of the CX-Protocol.</p>	
<p>2 The dialog box on the right is displayed. Click the Yes Button.</p>	
<p>3 Confirm that the operating mode was changed to the Monitor mode, and double-click NewPLC1.</p>	
<p>4 The tree under NewPLC1 expands. Select the Serial Communications Unit (SCU[0] is selected in the right figure).</p>	

5 Select the Trace 1 Icon (🔍) on the Project Window. (Confirm that Trace 1 is highlighted as shown in the right figure.)

*Trace 1 corresponds to port 1 of the Serial Communications Unit.

Trace	Status
Trace 1	Not Tracing
Trace 2	Not Tracing

Communications Port	Type
Communications Port 1	CS:RS232C, CJ:RS422/485
Communications Port 2	CS:RS422/485, CJ:RS232C

6 Select **Start Trace - One Shot Trace** from the PLC Menu.

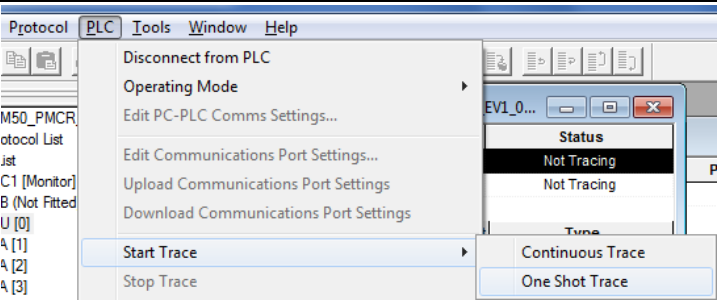

7 Confirm that the status of Trace 1 in the Project Window was changed to One-shot Trace Running.

Trace	Status
Trace 1	One-shot Trace Running
Trace 2	Not Tracing

Communications Port	Type
Communications Port 1	CS:RS232C, CJ:RS422/485
Communications Port 2	CS:RS422/485, CJ:RS232C

7.4.2. Executing the Program

Execute the program with the CX-Programmer.

<p>1 Expand the Programs Tree on the project workspace of the CX-Programmer, and double-click Section1. The Ladder Section Window shows the Section 1 ladder.</p>	
<p>2 On the Ladder Section Window, right-click Input_Start and select Set - On.</p> <p>*You can right-click any Input_Start contact. (Input_Start of Block 0 is operated in the right figure.)</p>	
<p>3 Confirm that the Input_Start contact is turned ON as shown in the right figure.</p>	

7.4.3. Checking the Trace Data

Confirm that the correct data is sent and received by checking the trace data of the CX-Protocol.

- 1 Select **Upload Trace** from the PLC Menu from the CX-Protocol.

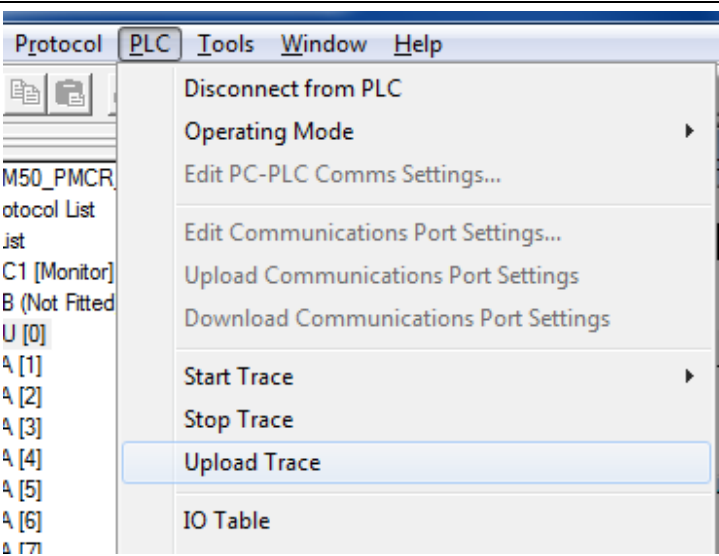

- 2 The dialog box on the right is displayed. Click the **Yes** Button.

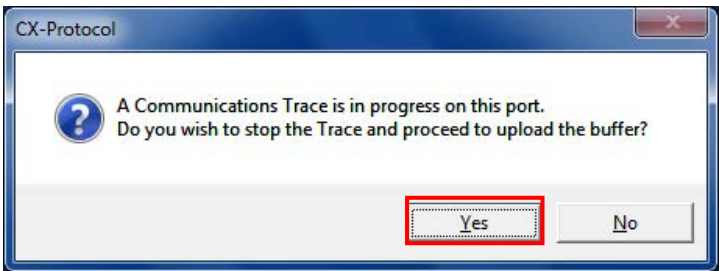

- 3 Check the receive message on the trace data file shown in the right figure.

(In the example on the right, 4B 4D 35 30 2D 45 31 20 20 20 is received in ASCII code and KM50-E1 in string format as the properties of the Smart Power Monitor.)

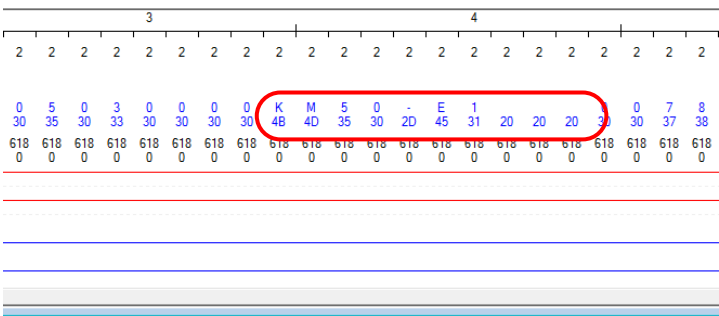

*In the example on the right, the received properties of the Smart Power Monitor are KM50-E1. However, the properties depend on the Smart Power Monitor used.

First row of receive message: Text string
 Second row of receive message: ASCII (Hex) code

7.4.4. Checking the Receive Data

Confirm that the correct data is written to the I/O memory of the PLC with the CX-Programmer.

1 Select **Edit - Memory** from the PLC Menu of the CX-Programmer.

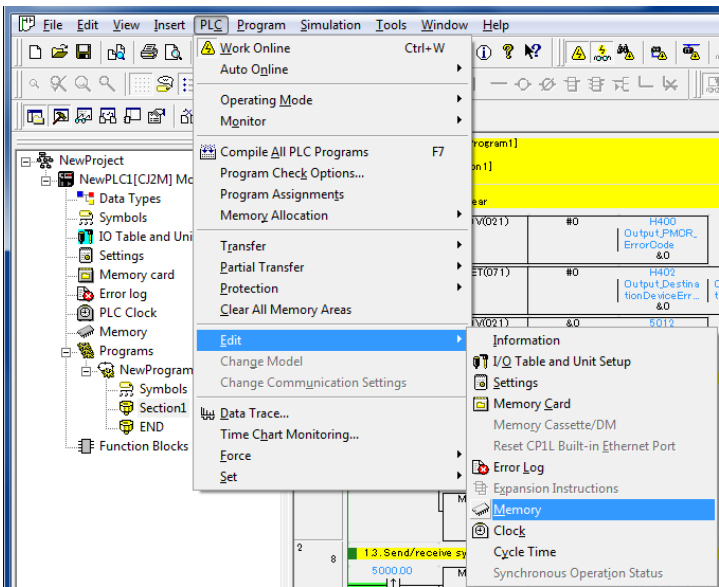

2 Double-click **CIO** from the list in the PLC Memory Window that is displayed.

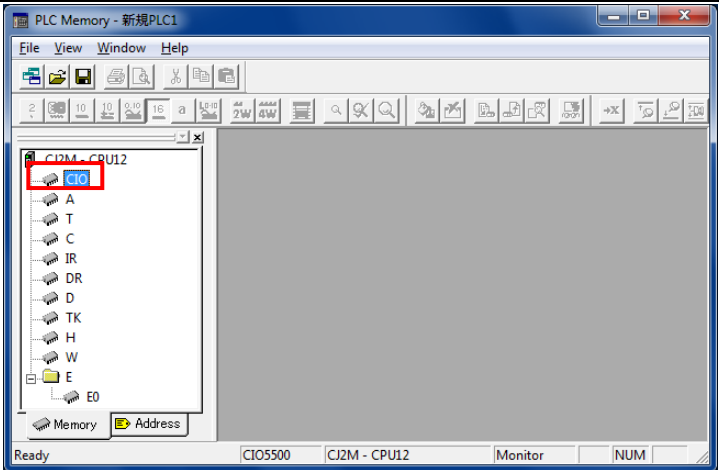

(PLC Memory Window)

3 Enter 5500 in the Start Address Field on the displayed CIO Window. Confirm that the start address was changed to CIO 5500.

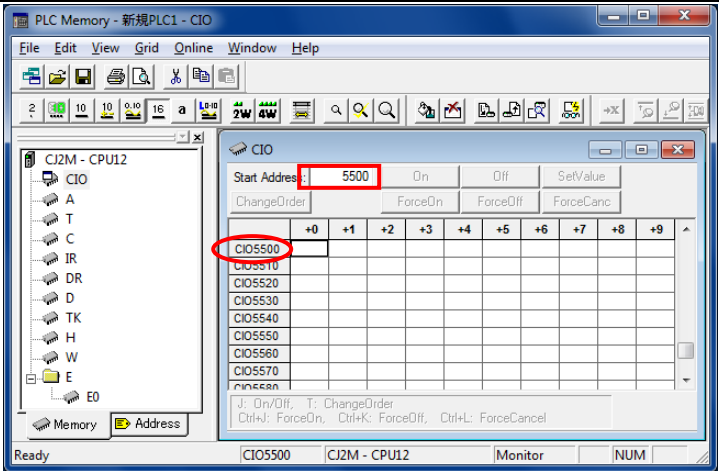

4 Select **Monitor** from the Online Menu.

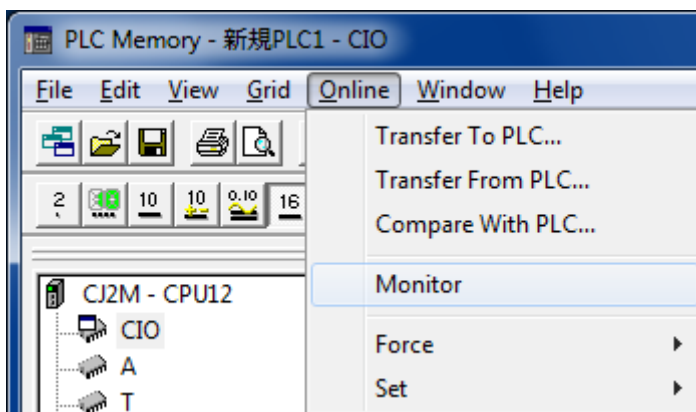

5 The Monitor Memory Areas Dialog Box is displayed. Select the **CIO** Check Box and click the **Monitor** Button.

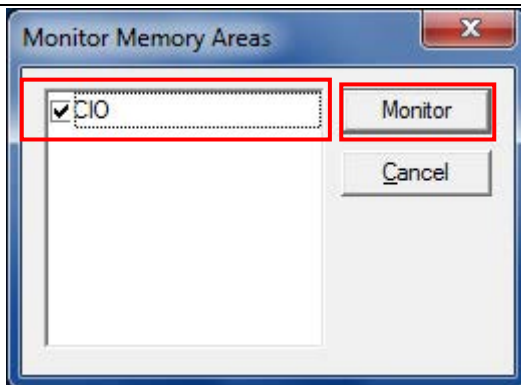

6 On the CIO Window, check the received data (model). (In the figure on the right, the data stored starting from CIO 5503 is 4B4D 3530 2D45 3120 2020 in hexadecimal (KM50-E1). It is the same as the data in step 3 of Section 7.4.3.)

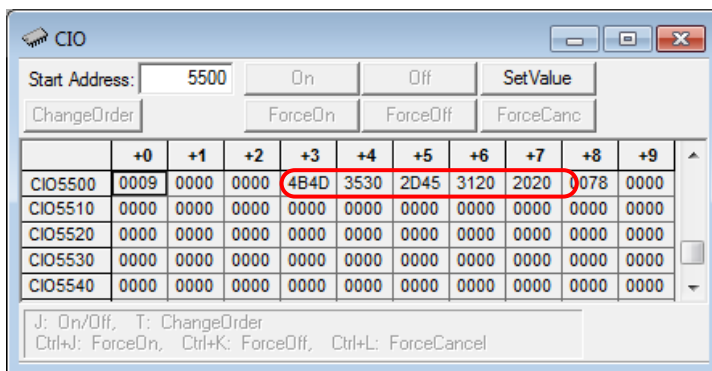

*The number of used words (9 words (9 in decimal)) is stored in CIO 5500. The ID code is stored from CIO 5502 to CIO 5508.

*Refer to 9.2.2. *PMCR Instruction Operand Settings* for details.

8. Initialization Method

This document explains the setting procedure from the factory default setting.

Some settings may not be applicable as described in this document unless you use the devices with the factory default setting.

8.1. Initializing the PLC

To initialize the PLC, it is necessary to initialize the Serial Communications Unit and the CPU Unit. Change to PROGRAM mode before initialization.

8.1.1. Serial Communications Unit

To initialize the settings of the Serial Communications Unit, select **Edit - I/O Table and Unit Setup** from the PLC Menu of the CX-Programmer.

On the PLC IO Table Dialog Box, right-click the Serial Communications Unit and select **Unit Setup** from the menu that is displayed.

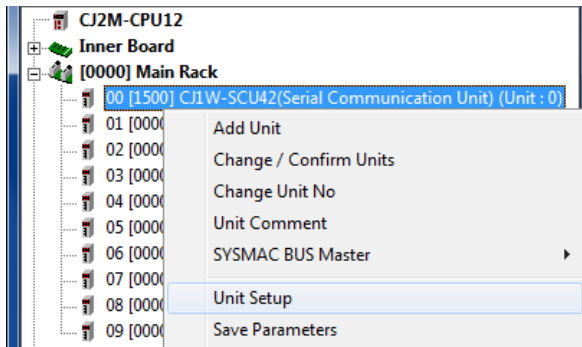

On the View Parameters Dialog Box, click the **Set Defaults** Button, and click the **Transfer (PC to Unit)** Button.

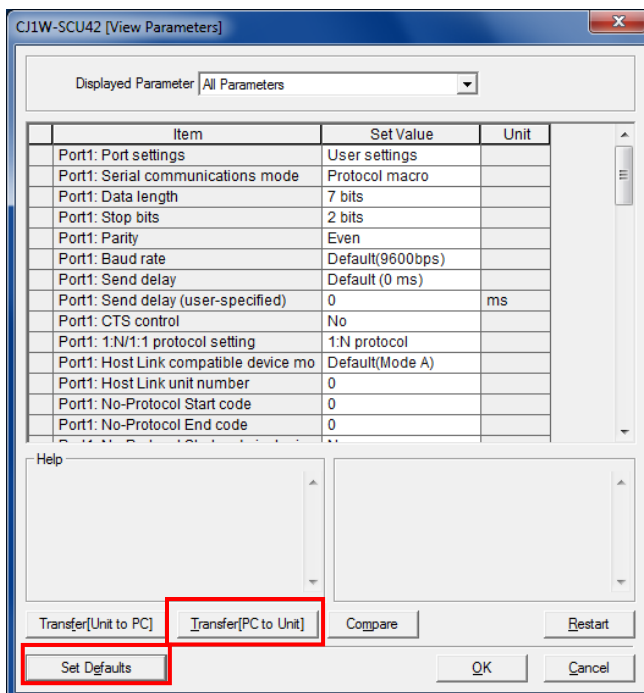

8.1.2. CPU Unit

To initialize the settings of the CPU Unit, select **Clear All Memory Areas** from the PLC Menu of the CX-Programmer. On the Confirm All Memory Area Clear Dialog Box, select the *Initialize* Option and click the **OK** Button.

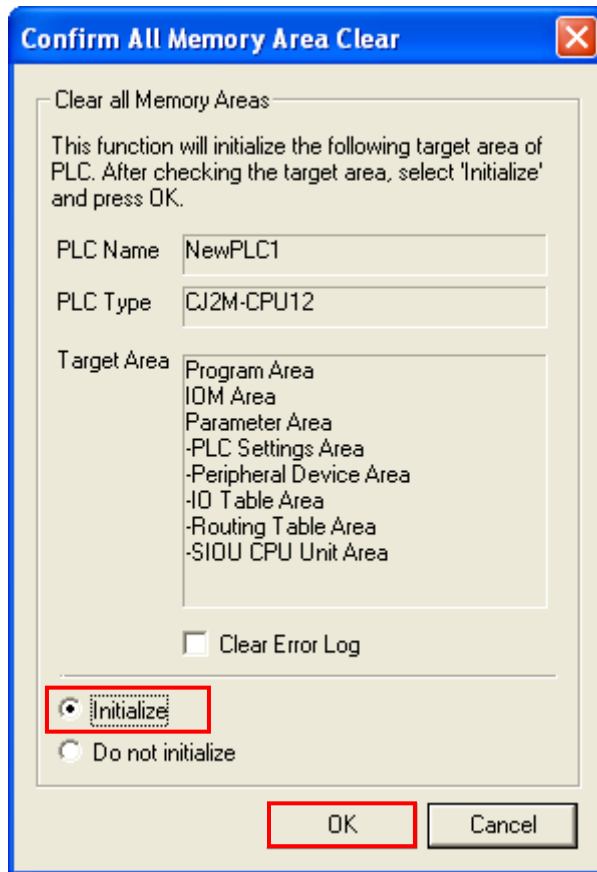

9. Program

This section describes the details on the program and the protocol macro data used in this document.

9.1. Overview

This section explains the specifications and functions of the program and the protocol macro data that are used to check the connection between the Smart Power Monitor (hereinafter referred to as the destination device) and the PLC (Serial Communications Unit) (hereinafter referred to as the Serial Communications Unit).

This program and protocol macro data use the protocol macro function of the Serial Communications Unit to send/receive the Unit Properties Read command to/from the destination device and to detect whether the operation ends normally or ends in an error.

A normal end of this program means a normal end of the communications sequence of the protocol macro.

An error end means a communications sequence error of the protocol macro and a destination device error (detected with the response data from the destination device).

In this section, the "&" prefix is added to decimal data and the "#" prefix is added to hexadecimal data when it is necessary to distinguish between decimal and hexadecimal data. (e.g., "&1000" for decimal data and "#03E8" for hexadecimal data)



Additional Information

OMRON has confirmed that normal communications can be performed using this program and protocol macro data under the OMRON evaluation conditions including the test system configuration, version and product lot number of each device which was used for evaluation. OMRON does not guarantee the normal operation under the disturbance such as electrical noise or the performance variation of the device.

9.1.1. Communications Data Flow

The following figure shows the data flow from when the PLC (Serial Communications Unit) issues command data via serial communications to the destination device until when it receives the response data from the destination device.

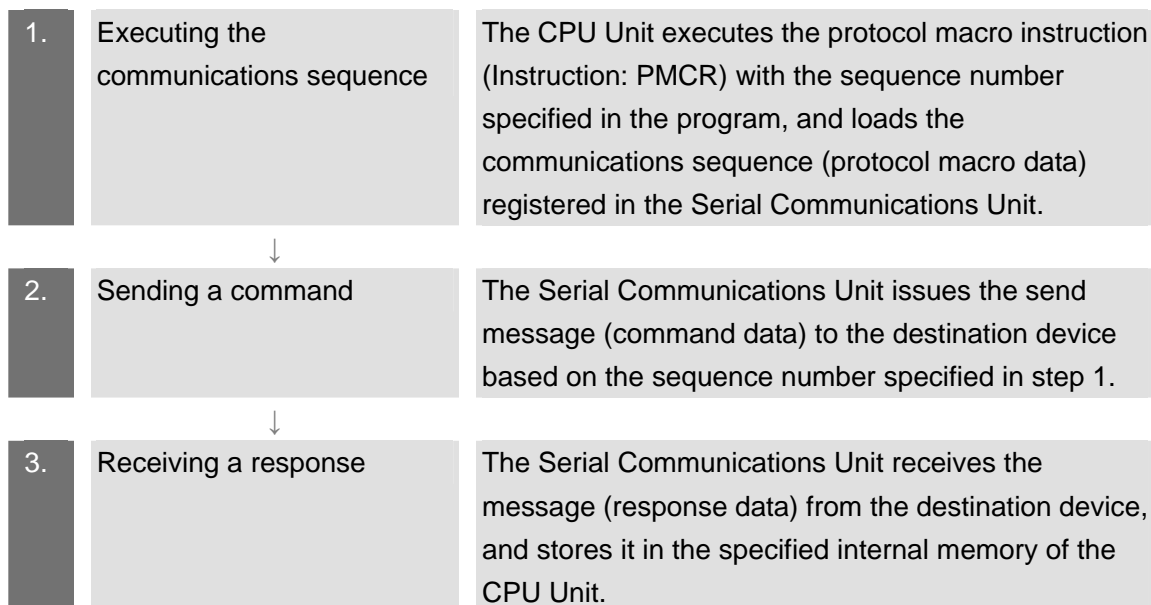

9.1.2. PMCR Instruction and Send/Receive Message

This section explains the protocol macro instruction (Instruction: PMCR, hereinafter referred to as the PMCR instruction) and outlines the general operation of the send/receive messages.



Additional Information

Refer to *Serial Communication Instructions (PMCR)* in *Section 3 Instructions* of the *CJ Series Instructions Reference Manual* (Cat. No. W474) for details.

●PMCR instruction operand data

Instruction	Mnemonic	Variations	Function code	Function
PROTOCOL MACRO	PMCR	@PMCR	260	Calls and executes a communications sequence registered in a Serial Communications Board (CS Series only) or Serial Communications Unit.

Symbol	PMCR										
		<table border="1"> <tr> <td>PMCR(260)</td> <td></td> </tr> <tr> <td>C1</td> <td>C1: Control word 1</td> </tr> <tr> <td>C2</td> <td>C2: Control word 2</td> </tr> <tr> <td>S</td> <td>S: First send word</td> </tr> <tr> <td>R</td> <td>R: First receive word</td> </tr> </table>	PMCR(260)		C1	C1: Control word 1	C2	C2: Control word 2	S	S: First send word	R
PMCR(260)											
C1	C1: Control word 1										
C2	C2: Control word 2										
S	S: First send word										
R	R: First receive word										

[C1: Control word]

Set the following 3 items for the Serial Communications Unit.

- Communications port No. (internal logical port): #0 to #7
- Serial port number (physical port): #1 or #2 (#1: PORT1, #2: PORT2)
- Unit address of destination device: # unit number + #10

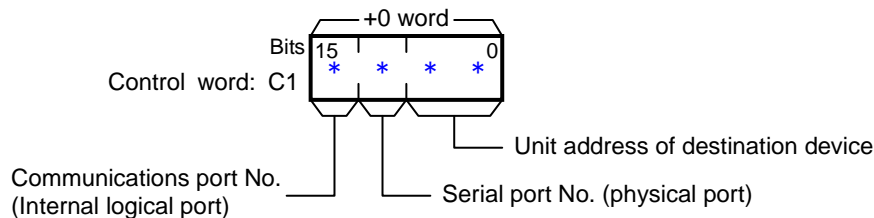

[C2: Control word 2]

Set the communications sequence number that is registered as the protocol macro data. For information on the sequence number registered in this protocol macro data, refer to 9.2.1 Communications Sequence Number.

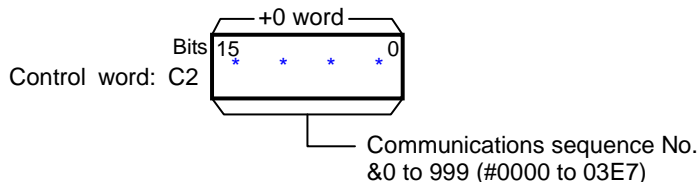

[S: First send word (send area specification)]

Set the number of words (n) to send. (Including S word)

Between #0000 and #00FA (&0 and &250) words can be set.

Enter the send data in the words from S+1 to S+(n-1).

If there is no operand specified in the execution sequence, such as a direct or linked word, set constant #0000 for S.

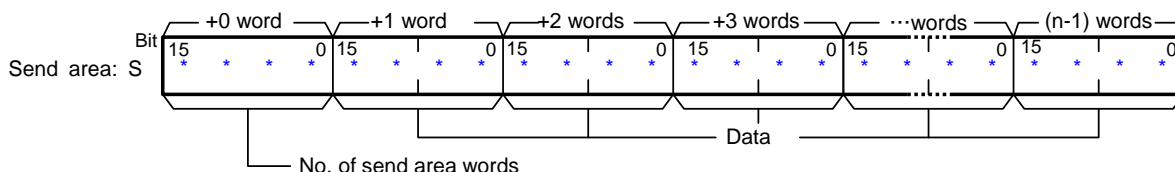

[R: First receive word (receive area specification)]

The number of the received data words (m) is automatically stored in R. (Including R word)

The received data is stored in the words from R+1 to R+(m-1). (m=&0 to &250 or #0000 to #00FA)

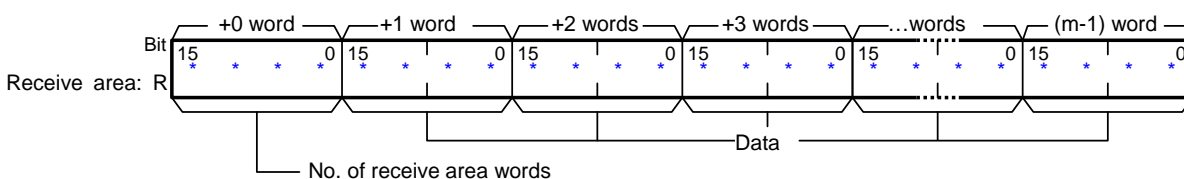

● Send/Receive messages

[Overview of send/receive messages]

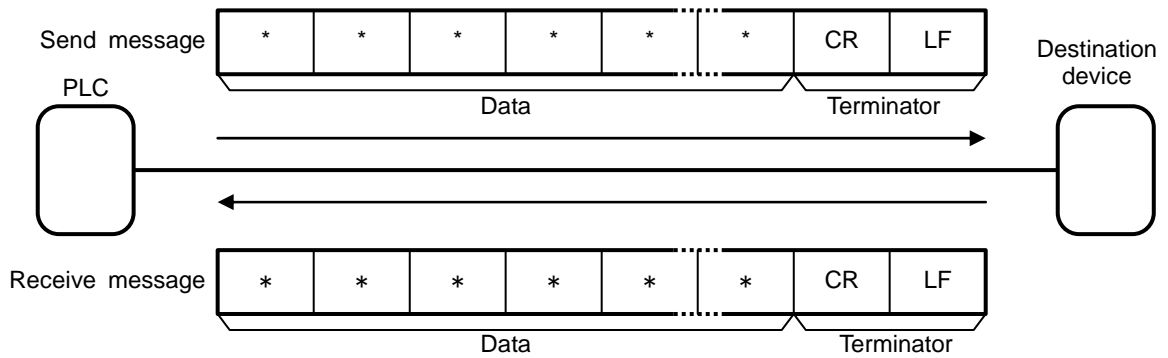

[Relationship between send area S (PMCR instruction operand) and send message]

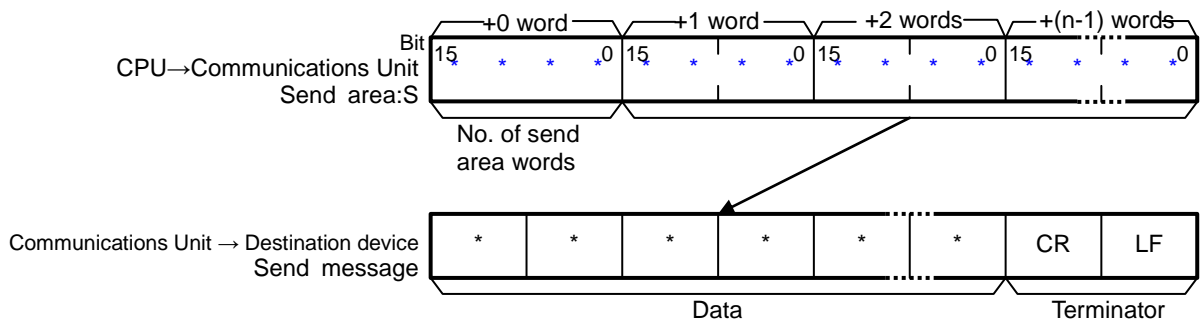

[Relationship between receive message and receive area R (PMCR instruction operand)]

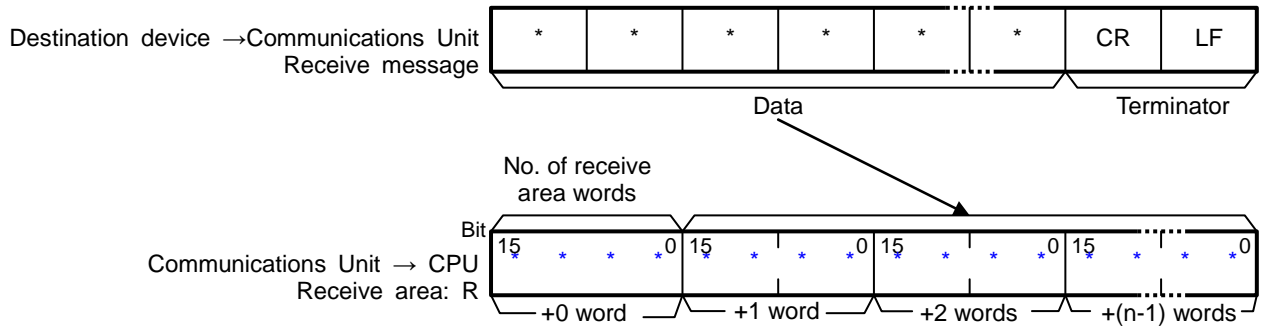

9.2. Communications Sequence

This section explains the communications sequence (protocol macro data) that can be used for the PMCR instruction of this program.

9.2.1. Communications Sequence Number

A communications sequence (protocol macro data) that is registered in the Serial Communications Unit is identified by a communications sequence number. The PLC executes the corresponding command on the destination device by specifying a communications sequence number in PMCR instruction.

This protocol macro data includes the following communications sequence that was created by editing a standard system protocol.

No.	Command name	Description
618	Unit Properties Read	Reads the properties of the destination device.

9.2.2. PMCR Instruction Operand Settings

The PMCR instruction operands of Unit Properties Read (Communications sequence No. 618 (#026A)) are shown below.

•Control word C1 settings (C1: CIO 5010)

Word	Description (data type)	Data (explanation)
C1	Communications port No. (1 digit hex)	#7110 (Communications port No. 7, Serial port No.1, #Unit number + #10)
	Serial port No. (1 digit hex)	
	Unit address of destination device (2 digit hex)	

•Control word C2 setting (C2: CIO 5011)

Word	Description (data type)	Data (explanation)
C2	Communications sequence No.	&618 (Unit Properties Read)

•Control word S settings (S: CIO 5020)

Word	Description (data type)	Data (explanation)
S	Number of words of send data (4-digit hex)	#0002 (Send data: 2 words)
S+1	Node number	#0001 (Destination node number)

•Control word R settings (R: CIO 5500)

Word	Description (data type)	Data (explanation)
R	Number of words of receive data (4-digit hex)	Receive data. Setting is unnecessary
R+1	Response code (CompoWay/F) (UINT)	
R+2	MRES/SRES(FINS-mini)(UINT)	
R+3	Model numbers 1 and 2 (WORD)	
R+4	Model numbers 3 and 4 (WORD)	
R+5	Model numbers 5 and 6 (WORD)	
R+6	Model numbers 7 and 8 (WORD)	
R+7	Model numbers 9 and 10 (WORD)	
R+8	Buffer size (WORD)	

9.3. Error Detection Processing

This program detects and handles the errors (1) to (3) below. For information on error codes, refer to 9.8 *Error Process*.

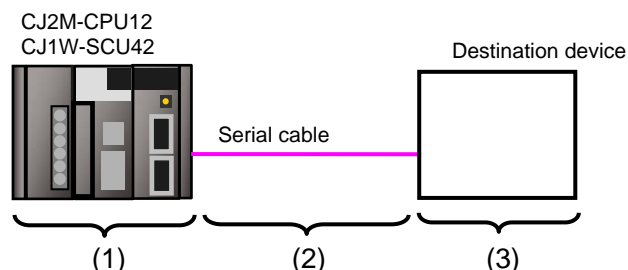

(1) Errors when executing the PMCR instruction (PMCR instruction error)

An incorrect sequence number and an incorrect memory address which prevent the execution of the PMCR instruction are detected as PMCR instruction errors. An error can be detected with error codes (1509.00 to 03) of the Port Operating Status in the CIO area allocated to the Serial Communications Unit.

(2) Errors when communicating with destination device (Communications error)

Errors that occur in communications with the destination device, such as character corruption and transmission errors caused by unmatched baud rate settings, are detected as "communications errors". The error can be detected with the Transmission Error Flag (1508.15) of Transmission Error Status in the CIO area allocated to the Serial Communications Unit.

(3) Errors in the destination device (Destination device errors)

Destination device errors include a command error, a parameter error, data error, and an execution failure in the destination device. An error is detected with the response data which is returned from the destination device. This program detects a destination device error when the format of a normal receive message (hereinafter referred to as a normal message) differs from the format of an error receive message (hereinafter referred to as an error message). (Refer to 9.6.6. *Receive Message Settings* for details.)

Normal message	STX	"01"	"00"	"00"	"03"	"05"	"00"	"00"	***	ETX	**
	Send Start	Node No.	Sub Address	End code	MRC	SRC	MRES	SRES	Data	Send End	BCC

Error message	STX	"01"	"00"	***	"03"	"05"	***	***	ETX	**
	Send start	Node No.	Sub Address	End code	MRC	SRC	MRES	SRES	Send end	BCC

Error message	STX	"01"	"00"	***	ETX	**
	Send start	Node No.	Sub address	End code	Send end	BCC

**Additional Information**

For information on the CIO area allocated to the Serial Communications Unit, refer to 9.4.2 *List of Fixed Allocations*.

9.4. Memory Maps

This section shows the memory maps of this program.

9.4.1. Lists of Addresses

The tables below list the addresses necessary to execute this program.

You can change the allocation below to any addresses.



Precautions for Correct Use

Make sure there is no duplicated address when changing the addresses.

•Input addresses

These addresses are used to operate this program.

Address	Data type	Symbol name	Explanation
5000.00	BOOL	Input_Start	When this flag changes from OFF to ON, the program starts.
5021	UINT	Input_DestinationNodeNo	Sets the node number of the destination device (send destination).

•Output addresses

The execution results of the program are stored in these addresses.

Address	Data type	Symbol name	Explanation
5000.02	BOOL	Output_NormalEnd	Turns ON when the program ends normally.
5000.03	BOOL	Output_ErrorEnd	Turns ON when one or more of the following errors occur. (1) PMCR instruction error (2) Communications error (3) Destination device error
5503	WORD	Model1_2	Stores model numbers 1 and 2 that were received from the destination device.
5504	WORD	Model3_4	Stores model numbers 3 and 4 that were received from the destination device.
5505	WORD	Model5_6	Stores model numbers 5 and 6 that were received from the destination device.
5506	WORD	Model7_8	Stores model numbers 7 and 8 that were received from the destination device.
5507	WORD	Model9_10	Stores model numbers 9 and 10 that were received from the destination device.
5508	WORD	BufferSize	Stores the buffer size that was received from the destination device.

Address	Data type	Symbol name	Explanation
H400	UINT	Output_PMCR_ErrorCode	Stores the error code when a PMCR instruction error or communications error occurs.
H402	UINT	Output_DestinationDeviceErrorCode[0]	Stores the error code received from the destination device when an error occurs in the destination device. (CompoWay/F)
H403	UINT	Output_DestinationDeviceErrorCode[1]	Stores the error code received from the destination device when an error occurs in the destination device. (FINS-mini)

● Internal addresses

These addresses are used to operate this program only.

Address	Data type	Symbol name	Explanation
5000.01	BOOL	Local_PMCRExecuting	Indicates the PMCR instruction execution status. Turns ON when the PMCR instruction is being executed, and turns OFF when the PMCR instruction is not executed.
5000.04	BOOL	Local_PMCRNormalEnd	Turns ON when the PMCR instruction ended normally.
5000.05	BOOL	Local_PMCRErrorEnd	Turns ON when a communications error (e.g., transmission error) occurs.
5000.06	BOOL	Local_DestinationDeviceError	Turns ON when a destination device error occurs.
5000.07	BOOL	Local_PMCRErrorCode	Turns ON when any of the following PMCR instruction errors occurs. (1) Sequence No. error (2) Symbol specification area exceeded error (3) Protocol macro syntax error
5010	UINT	Local_ControlWord1	Execution parameter of PMCR instruction
5011	UINT	Local_ControlWord2	Execution parameter of PMCR instruction
5012	UINT	Local_PMCR_ErrorCode	Stores the error code when a PMCR instruction error occurs.
5020	UINT	Local_FirstSendWord	Sets the number of send message words of the PMCR instruction.
5021	UINT	Local_SendData_NodeNo	Sets the destination device's node number to which to send.

Address	Data type	Symbol name	Explanation
5500	UINT	Local_FirstReceiveWord	Stores the number of message words received from the destination device.
5501	UINT	Local_ReceiveSymbolArea_ResponseCode[0]	Stores the error code of the destination device (end code of CompoWay/F) when an error occurs in the destination device.
5502	UINT	Local_ReceiveSymbolArea_ResponseCode[1]	Stores the error code of the destination device (MRES/SRES of FINS/mini) when an error occurs in the destination device.

9.4.2. List of Fixed Allocations

The tables below list the addresses necessary to execute this program.

- Allocated CIO area

They are the fixed addresses determined by the unit address (unit number) that is set for the Serial Communications Unit. Therefore, you must not change these allocations.

Unit number 0 is used in this program.

Address	Data type	Symbol name
1508.15	BOOL	TransmissionError_SCU_F_P1
1509.10	BOOL	SequenceAbortCompletion_SCU_F_P1
1509.11	BOOL	SequenceEndCompletion_SCU_F_P1
1509.15	BOOL	ProtocolMacroExecuting_SCU_F_P1
1509	UINT	ProtocolMacroErrorCode_SCU_F_P1



Additional Information

For details on the CIO area allocated to the Serial Communications Unit, refer to *Section 2-3-2 CIO Area of the CJ-series Serial Communications Boards and Serial Communications Units Operation Manual (Cat. No. W336)*.

- Related auxiliary area

The addresses of the following related auxiliary area are determined by the communications port (internal logical port) specified in the program (PMCR operand). Therefore, you must not change these allocations.

This program uses communications port (internal logical port) No. 7.

Address	Data type	Symbol name
A202.07	BOOL	CommPortEnabledFlag_P7



Additional Information

For information on related auxiliary area for the PMCR instruction, refer to *Related Auxiliary Area Words and Bits in Serial Communications instructions (PMCR) in Chapter 3 Instructions of CJ series Instructions Reference Manual (Cat. No. W474)*.

9.5. Ladder Program

9.5.1. Functional Components of the Ladder Program

The functional components of this program are shown below.

Major classification	Minor classification	Description
1. Initialization processing	1.1. Response code clear 1.2. Operand setting for PMCR instruction 1.3. Send/Receive symbol setting	The area to use is cleared and the initialization setting is performed as a preparation for communications.
2. PMCR instruction execution management	2.1. PMCR instruction executing 2.2. PMCR instruction execution processing 2.3. Normal/error detection processing	The communications sequence (protocol macro data) registered in the Serial Communications Unit is identified and executed. A normal end or an error end is detected based on the related flags and receive data.
3. Normal end state management	3.1. Normal end processing 3.2. Response code setting	The normal completion flag is turned ON. The response code for a normal end is set.
4. Error end state management	4.1. Error end processing 4.2. Response code setting	The error end flag is turned ON. The response code corresponding to the error cause is set.

9.5.2. Detailed Description of Each Functional Component

This section shows the program.

•1. Initialization processing

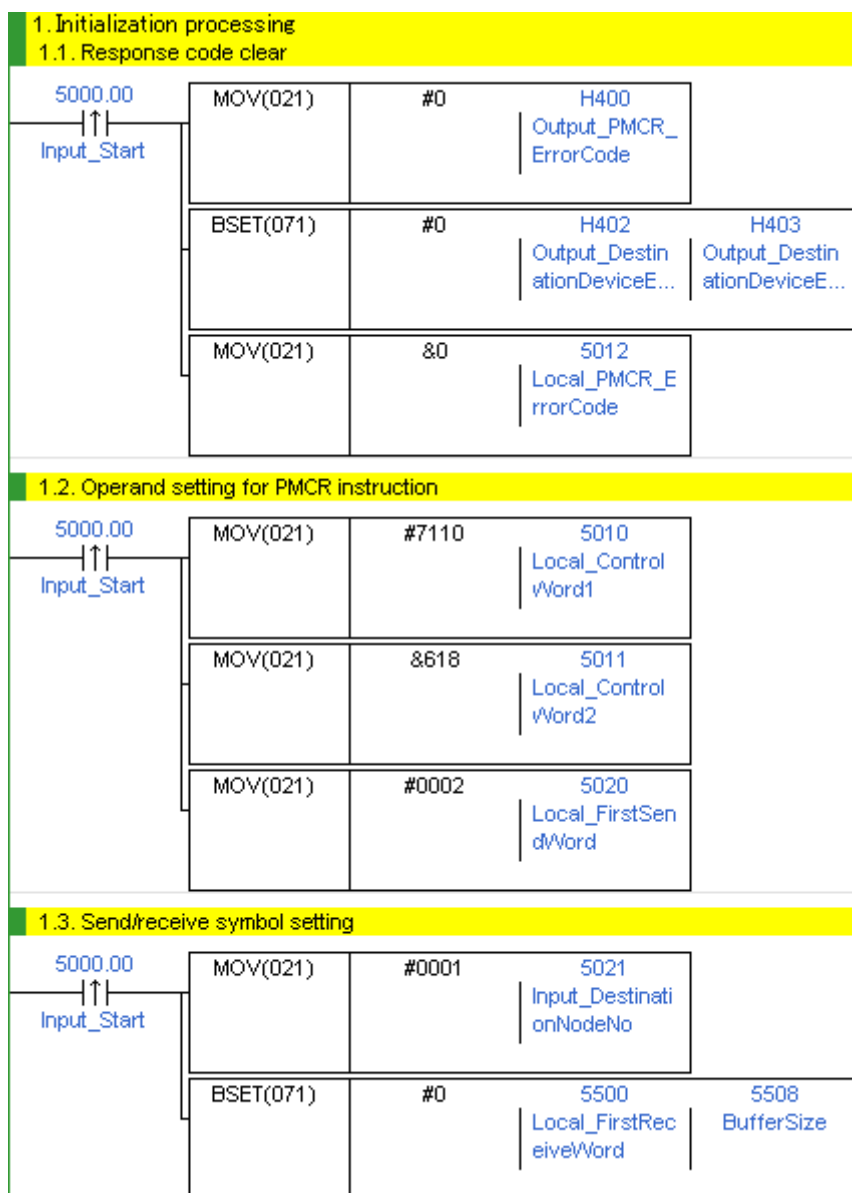

No.	Overview	Description
1.1.	Response code clear	Clears the error code storage area to 0.
1.2.	Operand setting for PMCR instruction	Sets the PMCR execution parameters (operands).
1.3.	Send/Receive symbol setting	Initializes the receive data storage area.

●2. PMCR instruction execution management

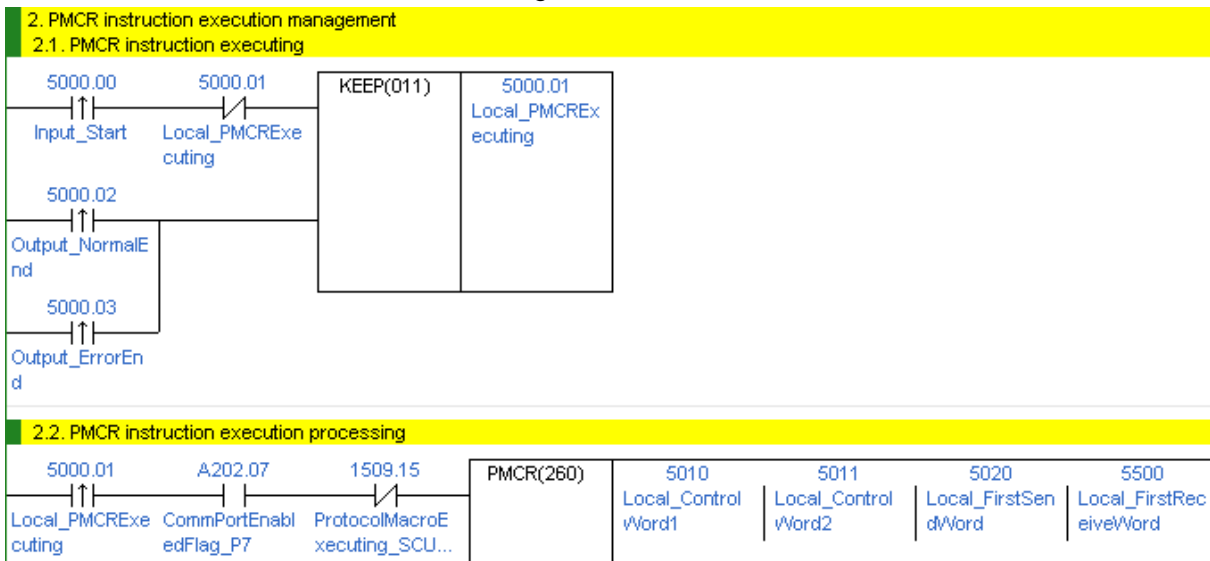

No.	Overview	Description
2.1.	PMCR instruction executing	Enters the PMCR instruction executing status. The executing state is reset at a normal end or an error end of the program.
2.2.	PMCR instruction execution processing	The PMCR instruction is executed under the following conditions. <ul style="list-style-type: none"> •Communications port No.7 can be used. •The PMCR instruction is not being executed.



Precautions for Safe Use

Make sure to sufficiently check the overall program before specifying the area to save the receive data of the PMCR instruction. Failure to do so may cause data to be written to an unintended memory area.



Precautions for Correct Use

This program uses communications port (internal logical port) No.7.
Do not use communications port No.7 for other purpose. If you have no choice but to use communication port No. 7, confirm that the Communications Port Enabled Flag (A202.07) is ON.

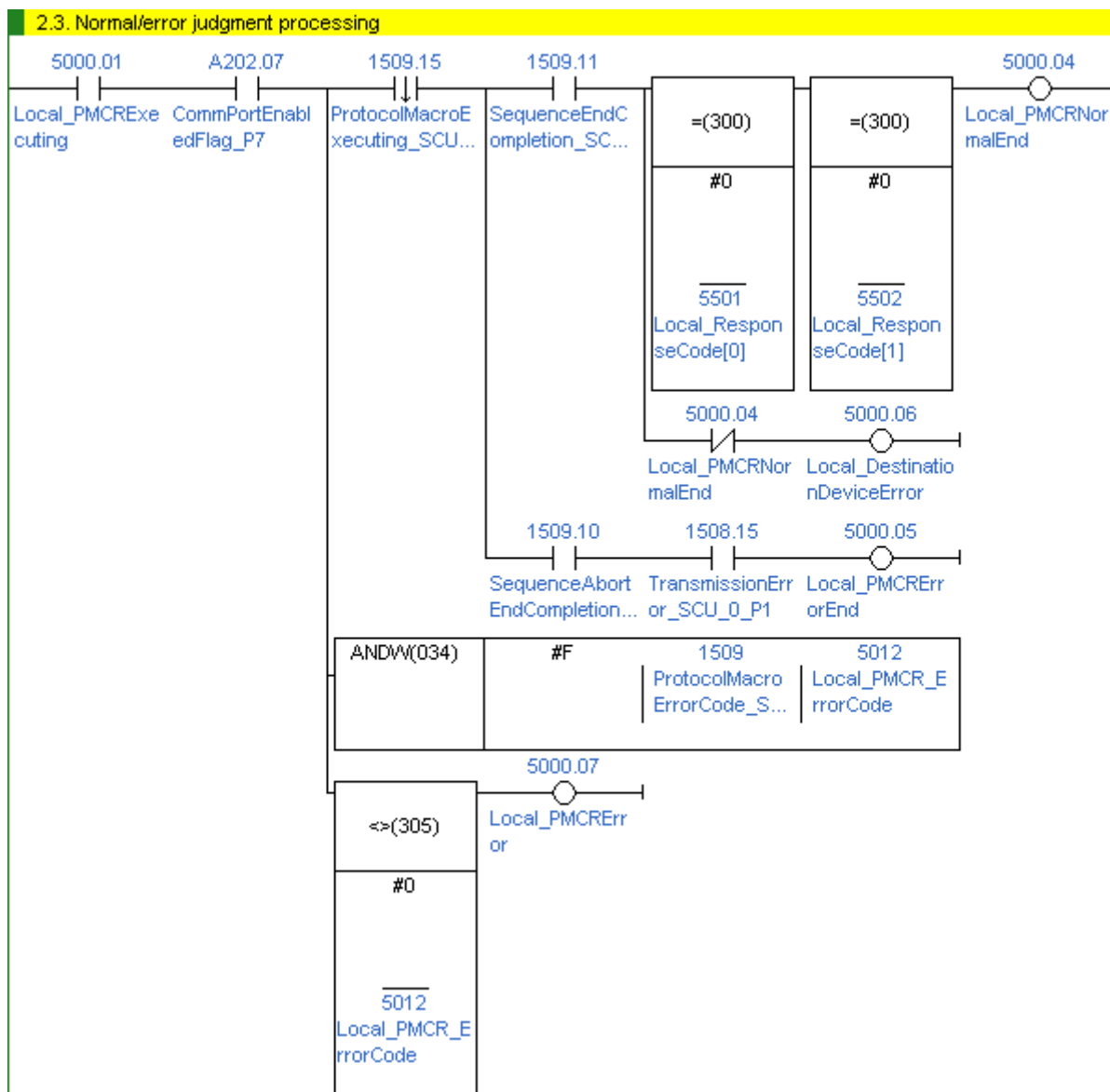

No.	Overview	Description
2.3.	Normal/Error detection processing	<p>Detects a normal end or error end of the program execution. It is considered as a normal end when all the following conditions are met.</p> <ul style="list-style-type: none"> (1)Normal end of PMCR instruction (No PMCR instruction error) (2)Normal end of communications sequence (No communications error) (3)Receives normal message from the destination device (No destination device error) <p>If any of the above errors occurs under the conditions above, the corresponding error flag will turn ON.</p>

●3. Normal end state management

3. Normal end state management
 3.1. Normal end processing

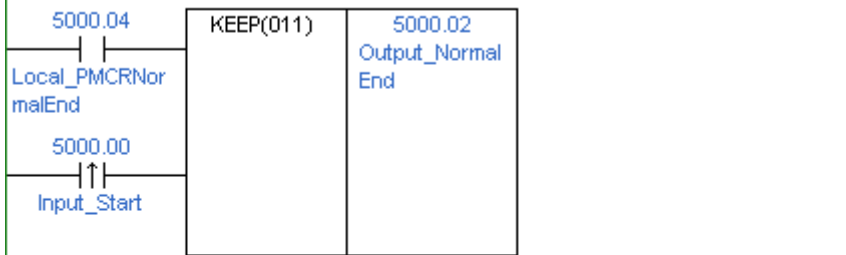

3.2. Response code setting

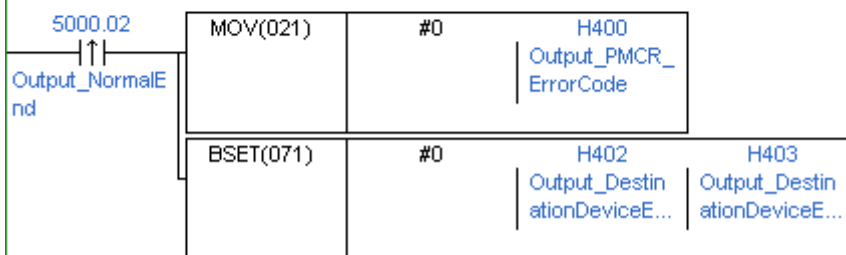

No.	Overview	Description
3.1.	Normal end processing	Turns ON the normal end flag if it is detected in 2.3 Normal/Error detection processing that the program ends normally.
3.2.	Response code setting	Sets response code "#0000" for a normal end in the response code storage area.

●4. Error end state management

4. Error completion state management
4.1. Error end processing

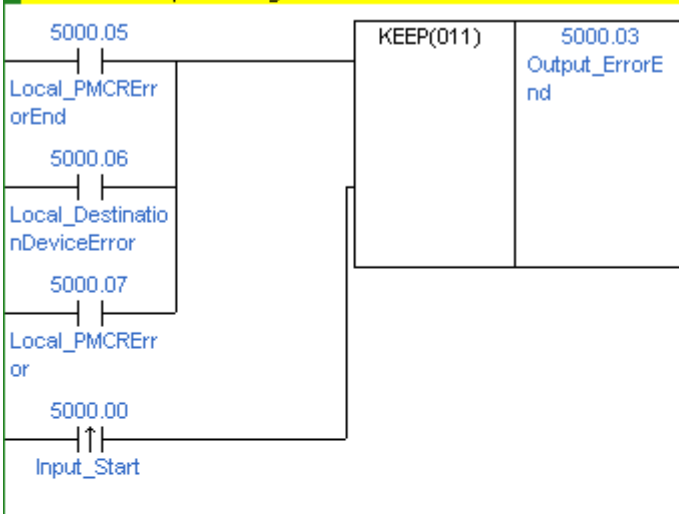

4.2. Response code setting

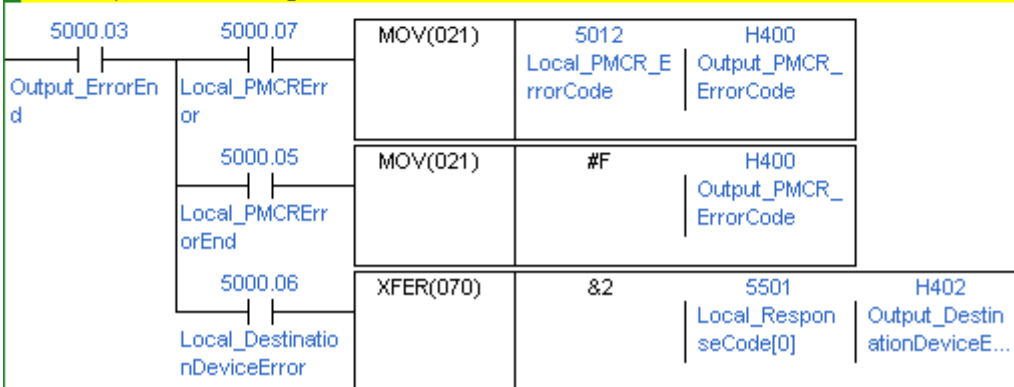

No.	Overview	Description
4.1.	Error end processing	Turns ON the error end flag if it is detected in 2.3 Normal/Error detection processing that the program ends in an error.
4.2.	Response code setting	Sets the response code corresponding to the error in the response code storage area when an error occurs.



Additional Information

Refer to 9.8 Error Process in this document for details on the response codes.

9.6. Protocol Macro Data

Protocol macro data consists of sequence, step, send/receive message, and matrix. Its composition is described as follows:

- When there is only one receive message format for a step (send/receive once)

- Set one send message and one receive message for the step.

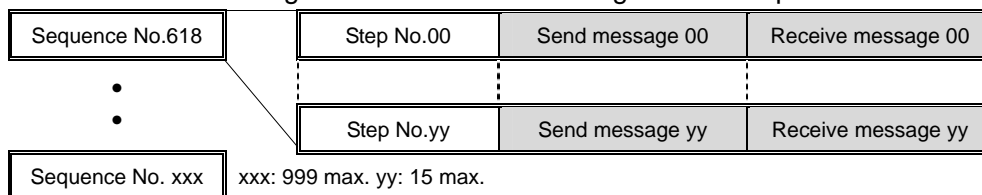

- When there are several types of receive message formats for a step (send/receive once)

- Set the send message and matrix for the step.

- Set several types of cases (receive messages) for the matrix.

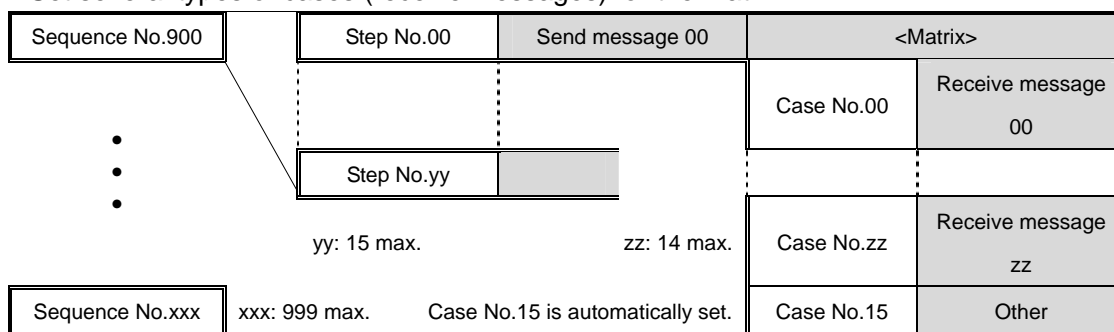

9.6.1. Composition of Protocol Macro Data

This protocol macro data uses a modified standard system protocol.

The protocol macro data uses three different types of receive message formats (one normal message and two error messages), and thus uses a matrix. The following shows its composition.

(Standard system protocol before modification)

Sequence No.618	Step No.00	SD PRO_R	RV PRO_R
-----------------	------------	----------	----------

(After modification)

Sequence No.618	Step No.00	SD PRO_R	<MX PRO_R>	
			Case No.00	RV PRO_R
			Case No.01	RV FINSERR
			Case No.02	RV COMFERR
			Case No.15	Other

*<MX PRO_R> For matrix reception (addition)

RV PRO_R: For normal message reception (syntax change)

RV FINSERR, RV COMFERR: For error message reception (addition)

(Refer to 9.6.6. Receive Message Settings for details.)

9.6.2. Protocol Macro Processing Procedure

This section describes the processing procedure of the protocol macro.

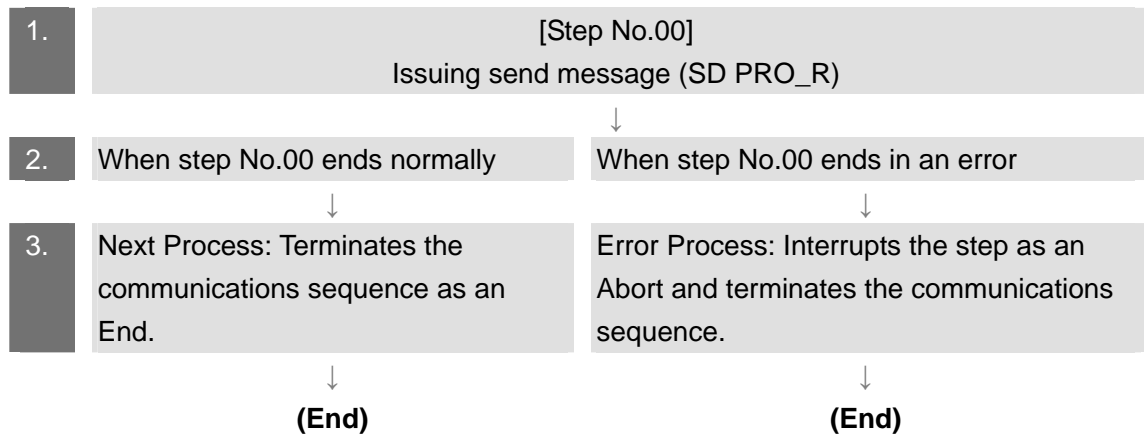

9.6.3. Sequence Settings

This protocol macro data executes Unit Properties Read by using communications sequence No.618. Set the timeout periods for the communications sequence.

- Timeout period setting

The following is the settings of the timeout periods (Timer Tr, Tfr, and Tfs) which are set for the sequence.

[Communications sequence setting screen]

#	Communication Sequence	Link Word	Control	Response	Timer Tr	Timer Tfr	Timer Tfs
600	ASCII change	---	Set	Scan	3 sec	3 sec	3 sec
601	ASCII change ALL	---	Set	Scan	3 sec	3 sec	3 sec
602	NO change	---	Set	Scan	3 sec	3 sec	3 sec
603	NO change ALL	---	Set	Scan	3 sec	3 sec	3 sec
604	General	---	Set	Scan	3 sec	3 sec	3 sec
605	General ALL	---	Set	Scan	3 sec	3 sec	3 sec
606	ASCII change2	---	Set	Scan	3 sec	3 sec	3 sec
607	ASCII change3	---	Set	Scan	3 sec	3 sec	3 sec
610	MEM Read	---	Set	Scan	3 sec	3 sec	3 sec
611	MEM Write	---	Set	Scan	3 sec	3 sec	3 sec
612	MEM Write ALL	---	Set	Scan	3 sec	3 sec	3 sec
613	MEM Fill	---	Set	Scan	3 sec	3 sec	3 sec
614	MEM Fill ALL	---	Set	Scan	3 sec	3 sec	3 sec
615	PARA Read	---	Set	Scan	3 sec	3 sec	3 sec
616	PARA Write	---	Set	Scan	3 sec	3 sec	3 sec
617	PARA Write ALL	---	Set	Scan	3 sec	3 sec	3 sec
618	Properties Read	---	Set	Scan	3 sec	3 sec	3 sec

<Settings>

Item	Description	Explanation
Timer Tr	Receive wait monitoring time	Monitors the time from the receive wait status to the reception of the first data (header) in the step of the sequence. This timer is set to 3 seconds in this protocol macro data.
Timer Tfr	Receive finished monitoring time	Monitors the time from the reception of the first data to the completion of the reception in the step of the sequence. This timer is set to 3 seconds in this protocol macro data.
Timer Tfs	Send finished monitoring time	Monitors the time from the sending of the header to the sending of the last data. This timer is set to 3 seconds in this protocol macro data.



Additional Information

Refer to *Section 4-5 Calculation Method of Monitoring Time of the CX-Protocol Operation Manual* (Cat. No. W344) for the calculation method of monitoring time.

9.6.4. Step Settings

This section describes the step settings for communications sequence No.618. The settings include retry count, send/receive messages (message names), next process, and error process. The sequence of this protocol macro data includes Step No.00 only.



Additional Information

Refer to 3-3 Step Attributes of the *CX-Protocol Operation Manual* (Cat. No. W344) for details on step settings.

●Retry count setting

This section describes the retry count setting for the step. The step is retried for the specified number of times (0 to 9 times) when an error occurs. If an error occurs after retries, the step moves to the error process.

<Step setting screen>

Step	Repeat	Command	Retry	Send Wait	Send Message	Recv Message	Response	Next	Error
00	RSET/001	Send & Receive	3	---	SD PRO_R	<MX PRO_R>	YES	Matrix	Abort

<Settings>

Step No.	Retry count
00	3

●Send/Receive message (message name) settings

This section describes the settings for the send/receive messages of the step. Here, a registered send message name and matrix name are selected.

<Step setting screen>

Step	Repeat	Command	Retry	Send Wait	Send Message	Recv Message	Response	Next	Error
00	RSET/001	Send & Receive	3	---	SD PRO_R	<MX PRO_R>	YES	Matrix	Abort

<Settings>

Step No.	Send message	Receive message
00	SD PRO_R	<MX PRO_R>

*The receive message in <> is the matrix name. When there are multiple receive message formats, use the matrix.

- Next process and error process settings

This section describes the settings for the next process and error process of the step. The process set in the Next Column is executed when the step execution ends normally. If a communications error occurs, the process set in the Error Column is executed.

<Step setting screen>



Step	Repeat	Command	Retry	Send Wait	Send Message	Recv Message	Respons	Next	Error
00	RSET001	Send & Receive	3	---	SD PRO_R	<MX PRO_R>	YES	Matrix	Abort

<Settings>

Step No.	Next process	Error process
00	Matrix	Abort

<Process list>

Process	Description
End	Ends the communications sequence.
Next	Moves to the next step No.
Abort	Interrupts the step and ends the communications sequence.
Goto	Moves to the specified step number.
Matrix	Uses the settings of the matrix.

9.6.5. Send Message Settings

This section explains the settings of the send message.

<Send message setting screen>

Send Message	Header <h>	Terminator <t>	Check code <c>	Length <l>	Address <a>	Data
SD ASC	STX	ETX	LRC (H parity)(0) (1Byte BIN)		\$(R(1),2)	<h>++\"00\"+\"0\"+\$(R(2),4)+\$(R(4),R(3))+<t>+<c>
SD ASC ALL	STX	ETX	LRC (H parity)(0) (1Byte BIN)		\"XX\"	<h>++\"00\"+\"0\"+\$(R(2),4)+\$(R(4),R(3))+<t>+<c>
SD NO	STX	ETX	LRC (H parity)(0) (1Byte BIN)		\$(R(1),2)	<h>++\"00\"+\"0\"+\$(R(2),4)+\$(R(4),R(3))+<t>+<c>
SD NO ALL	STX	ETX	LRC (H parity)(0) (1Byte BIN)		\"XX\"	<h>++\"00\"+\"0\"+\$(R(2),4)+\$(R(4),R(3))+<t>+<c>
SD GE	STX	ETX	LRC (H parity)(0) (1Byte BIN)		\$(R(1),2)	<h>++\$(R(2),2)+\$(R(3),1)+\$(R(4),R(3))+<t>+<c>
SD GE ALL	STX	ETX	LRC (H parity)(0) (1Byte BIN)		\"XX\"	<h>++\$(R(2),2)+\$(R(3),1)+\$(R(4),R(3))+<t>+<c>
SD ASC2	STX	ETX	LRC (H parity)(0) (1Byte BIN)		\$(R(1),2)	<h>++\"00\"+\"0\"+\$(R(2),2)+\$(R(2),2)+\$(R(3),4)+\$(R(4),4)+<t>+<c>
SD MEM_R	STX	ETX	LRC (H parity)(0) (1Byte BIN)		\$(R(1),2)	<h>++\"00\"+\"0\"+\"0101\"+\$(R(2),2)+\$(R(2),2)+\$(R(3),4)+\$(R(4),4)+<t>+<c>
SD MEM_W	STX	ETX	LRC (H parity)(0) (1Byte BIN)		\$(R(1),2)	<h>++\"00\"+\"0\"+\"0102\"+\$(R(2),2)+\$(R(2),2)+\$(R(3),4)+\$(R(4),4)+\$(R(6),R(5))+<t>+<c>
SD MEM_W A	STX	ETX	LRC (H parity)(0) (1Byte BIN)		\"XX\"	<h>++\"00\"+\"0\"+\"0102\"+\$(R(2),2)+\$(R(2),2)+\$(R(3),4)+\$(R(4),4)+\$(R(6),R(5))+<t>+<c>
SD MEM_F	STX	ETX	LRC (H parity)(0) (1Byte BIN)		\$(R(1),2)	<h>++\"00\"+\"0\"+\"0103\"+\$(R(2),2)+\$(R(2),2)+\$(R(3),4)+\$(R(4),4)+\$(R(5),4)+<t>+<c>
SD MEM_F A	STX	ETX	LRC (H parity)(0) (1Byte BIN)		\"XX\"	<h>++\"00\"+\"0\"+\"0103\"+\$(R(2),2)+\$(R(2),2)+\$(R(3),4)+\$(R(4),4)+\$(R(5),4)+<t>+<c>
SD PAR_R	STX	ETX	LRC (H parity)(0) (1Byte BIN)		\$(R(1),2)	<h>++\"00\"+\"0\"+\"0201\"+\$(R(2),4)+\$(R(3),4)+\$(R(4),4)+<t>+<c>
SD PAR_W	STX	ETX	LRC (H parity)(0) (1Byte BIN)		\$(R(1),2)	<h>++\"00\"+\"0\"+\"0202\"+\$(R(2),4)+\$(R(3),4)+\$(R(4),4)+\$(R(6),R(5))+<t>+<c>
SD PAR_W A	STX	ETX	LRC (H parity)(0) (1Byte BIN)		\"XX\"	<h>++\"00\"+\"0\"+\"0202\"+\$(R(2),4)+\$(R(3),4)+\$(R(4),4)+\$(R(6),R(5))+<t>+<c>
SD PRO_R	STX	ETX	LRC (H parity)(0) (1Byte BIN)		\$(R(1),2)	<h>++\"00\"+\"0\"+\"0503\"+<t>+<c>
SD STS_R	STX	ETX	LRC (H parity)(0) (1Byte BIN)		\$(R(1),2)	<h>++\"00\"+\"0\"+\"0601\"+<t>+<c>

●Settings of SD PRO_R send message

<Settings>

<h>+<a>+\"00\"+\"0\"+\"0503\"+<t>+<c>
 (1) (2) (3) (4) (5)

No.	Code	Description
(1)	<h >(Header)	Type: Code, Data: 02 Hex
(2)	<a >(Address) \$(R(1),2)	(R(1),2): Converts 2-byte data and sends it from the [first send word specified with the PMCR instruction operand + 1 word]. \$: Forward direction ASCII conversion (Converts the send message from hexadecimal code to ASCII code, and outputs the send data from the lower byte. (S+1 word Local_SendDataNodeNo)
(3)	“00”, “0”, “0503”	Constant ASCII
(4)	<t>(Terminator)	Type: Code, Data: 03 Hex
(5)	<c> (Check code)	Type: LRC (horizontal parity) (0) (1-byte BIN) Setting range: 2 to 6

<Send message command format>

This section shows a command format of the message that is sent from the Serial Communications Unit to the destination device according to the settings of SD PRO_R.

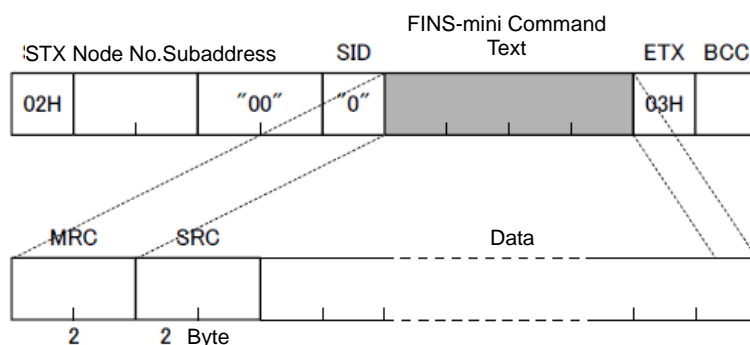

Command	Number of bytes	Remarks
STX	1	Fixed: STX (This code indicates the start of the communications frame.)
Node number	2	Variable: "01" to "99" ("xx" as broadcasting) can be set. The address for this protocol macro data is set to 01.
Subaddress	2	Fixed: 00 (Not used for KM50.)
SID	1	Fixed: 00 (Not used for KM50.)
MRC	2	05 is set in this protocol macro data. (Reads the properties of the destination device.)
SRC	2	03 is set in this protocol macro data. (Reads the properties of the destination device.)
Data *	0 and greater	Not used for the Unit Properties Read command.
ETX	1	Fixed: ETX (This code indicates the end of the text.)
BCC	1	Block check character. Stores the result of the BCC calculation from the node number to ETX.

*When it is not used, ETX is shifted to this position.

9.6.6. Receive Message Settings

This section describes the settings of the receive message. The receive messages corresponding to two response formats (normal message and error message) are set. For information on the normal message and error messages, refer to (3) of 9.3. *Error Detection Processing*.



Additional Information

Refer to 3-4 *Communication Message Attributes* of the *CX-Protocol Operation Manual* (Cat. No. W344) for details on receive message settings.

<Receive message setting screen>

Receive Message	Header <h>	Terminator <t>	Check code <c>	Length <l>	Address <a>	Data
RV ASC	STX	ETX	LRC (H parity)(0) (1Byte BIN)		\$(R(1),2)	<h>+<a>+"00"+00+\$(R(2),4)+8*(W(1),4)+8*(W(2),1)+<t>+<c>
RV NO	STX	ETX	LRC (H parity)(0) (1Byte BIN)		\$(R(1),2)	<h>+<a>+"00"+00+\$(R(2),4)+8*(W(1),4)+8*(W(2),1)+<t>+<c>
RV GE	STX	ETX	LRC (H parity)(0) (1Byte BIN)		\$(R(1),2)	<h>+<a>+\$(R(2),2)+00+(R(5),4)+8*(W(1),4)+8*(W(2),1)+<t>+<c>
RV ASC2	STX	ETX	LRC (H parity)(0) (1Byte BIN)		\$(R(1),2)	<h>+<a>+"00"+00+\$(R(2),4)+8*(W(1),4)+8*(W(2),1)+<t>+<c>
RV MEM_R	STX	ETX	LRC (H parity)(0) (1Byte BIN)		\$(R(1),2)	<h>+<a>+"00"+(*,2)*0101+8*(W(1),4)+8*(W(2),1)+<t>+<c>
RV MEM_W	STX	ETX	LRC (H parity)(0) (1Byte BIN)		\$(R(1),2)	<h>+<a>+"00"+(*,2)*0102+8*(W(1),4)+<t>+<c>
RV MEM_F	STX	ETX	LRC (H parity)(0) (1Byte BIN)		\$(R(1),2)	<h>+<a>+"00"+(*,2)*0103+8*(W(1),4)+<t>+<c>
RV PAR_R1	STX	ETX	LRC (H parity)(0) (1Byte BIN)		\$(R(1),2)	<h>+<a>+"00"+(*,2)*0201+8*(W(1),4)+8*(W(2),4)+8*(W(3),4)+8*(W(4),4)+8*(W(5),1)+<t>+<c>
RV PAR_R2	STX	ETX	LRC (H parity)(0) (1Byte BIN)		\$(R(1),2)	<h>+<a>+"00"+(*,2)*0201+8*(W(1),4)+<t>+<c>
RV PAR_W	STX	ETX	LRC (H parity)(0) (1Byte BIN)		\$(R(1),2)	<h>+<a>+"00"+(*,2)*0202+8*(W(1),4)+<t>+<c>
RV PRO_R	STX	ETX	LRC (H parity)(0) (1Byte BIN)		\$(R(1),2)	<h>+<a>+"00"+8*(W(1),2)+0503+8*(W(2),4)+8*(W(3),10)+8*(W(8),4)+<t>+<c>
RV STS_R	STX	ETX	LRC (H parity)(0) (1Byte BIN)		\$(R(1),2)	<h>+<a>+"00"+(*,2)*0801+8*(W(1),4)+8*(W(2),1)+<t>+<c>
RV TEST	STX	ETX	LRC (H parity)(0) (1Byte BIN)		\$(R(1),2)	<h>+<a>+"00"+(*,2)*0801+8*(W(1),4)+8*(W(2),1)+<t>+<c>
RV OFF_CMD	STX	ETX	LRC (H parity)(0) (1Byte BIN)		\$(R(1),2)	<h>+<a>+"00"+(*,2)*3005+8*(W(1),4)+8*(W(2),1)+<t>+<c>
RV FINSERR	STX	ETX	LRC (H parity)(0) (1Byte BIN)		\$(R(1),2)	<h>+<a>+"00"+8*(W(1),2)+0503+8*(W(2),4)+<t>+<c>
RV COMFERR	STX	ETX	LRC (H parity)(0) (1Byte BIN)		\$(R(1),2)	<h>+<a>+"00"+8*(W(1),2)+<t>+<c>

- Detection of normal message and error message

This protocol macro data detects a normal message or an error message based on the response code of the receive message.

- Settings of RV PRO_R receive message (normal message)

<Settings>

<h>+<a>+"00"+&(W(1),2)+0503+&(W(2),4)+&(W(3),10)+&(W(8),4)+<t>+<c>
 (1) (2) (3) (4) (3) (5) (6) (7) (8) (9)

The RV PRO_R standard system protocol reads and discards a CompoWay/F communications error at (,2). This protocol macro data stores the error as shown at &(W(1),2) of (4) to detect whether there is an error or not.

<h>+<a>+"00"+(*,2)+0503+&(W(1),4)+&(W(2),10)+&(W(8),4)+<t>+<c>

- Settings of RV FINSERR message (error message)

<Settings> (FINS-mini protocol error detection)

<h>+<a>+"00"+&(W(1),2)+0503+&(W(2),4)+<t>+<c>
 (1) (2) (3) (4) (3) (5) (8) (9)

- Settings of RV COMFERR message (error message)

<Settings> (CompoWay/F protocol error detection)

<h>+<a>+"00"+&(W(1),2)+<t>+<c>
 (1) (2) (3) (4) (8) (9)

No.	Code	Description
(1)	<h >(Header)	Type: Code, Data: 02 Hex
(2)	<a >(Address) \$(R(1),2)	(R(1),2): Converts 2-byte data and compares the receive data with the [first send word specified with the PMCR instruction operand + 1 word]. \$: Forward direction ASCII conversion (Converts the send message from hexadecimal code to ASCII, and outputs the send data from the lower byte).
(3)	"00"、"0503"	Constant ASCII
(4)	&(W(1),2)	(W(1),2): Converts 2-byte data and stores it in the [first receive word specified with the PMCR instruction operand + 1 word]. &: Forward direction hexadecimal conversion (Converts the receive message from ASCII code to hexadecimal, and outputs the receive data from the lower byte)
(5)	&(W(2),4)	(W(2),4): Converts 4-byte data and stores it in the [first receive word specified with the PMCR instruction operand + 2-word]. &: Forward direction hexadecimal conversion (Converts the receive message from ASCII code to hexadecimal, and outputs the receive data from the rightmost byte)
(6)	(W(3),10)	(W(3),10): Converts 10-byte data and stores it in the [first receive word specified with the PMCR instruction operand + 3-word].
(7)	&(W(8),4)	(W(8),4): Converts 4-byte data and stores it in the [first receive word specified with the PMCR instruction operand + 8-word]. &: Forward direction hexadecimal conversion (Converts the receive message from ASCII code to hexadecimal, and outputs the receive data from the rightmost byte)
(8)	<t>(Terminator)	Type: Code, Data: 03 Hex
(9)	<c>(Check code)	Type: LRC (horizontal parity) (0) (1-byte BIN) Setting range: RV PRO_R = 2 to 9 RV FINSERR=2 to 7 RV COMFERR=2 to 5

<Response format of receive message>

This is the response format of the receive message which is received by the Serial Communications Unit from the destination device.

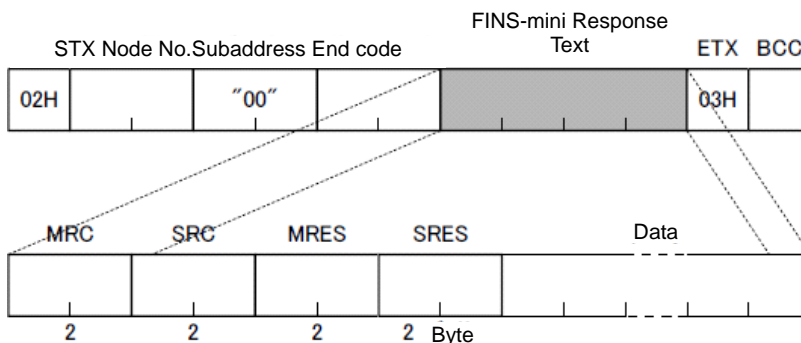

Command	Number of bytes	Remarks
STX	1	Fixed: STX (This code indicates the start of the communications frame.)
Node number	2	Variable: "01" to "99" The unit number of the destination device that returns the response. The address for this protocol macro data is set to 01.
Subaddress	2	Fixed: 00 (Not used for KM50.)
End code	2	Destination device error code[0] (CompoWay/F) (Refer to 9.8 Error Process.)
MRC *1	2	Returns the send command value. Returns 05 for this protocol macro data. (Reads the properties of the destination device.)
SRC *1	2	Returns the send command value. Returns 03 for this protocol macro data. (Reads the properties of the destination device.)
MRES *1	2	Destination device error code [1] (FINS-mini) (Refer to 9.8 Error Process.)
SRES *1	2	Destination device error code [1] (FINS-mini) (Refer to 9.8 Error Process.)
Data *1*2	0 and greater	(Reads the model (fixed to 10 bytes) and communications buffer size with the Unit Properties Read command.)
ETX	1	Fixed: ETX (This code indicates the end of the text.)
BCC	1	Block check character. Stores the result of the BCC calculation from the node number to ETX.

*1 When the CompoWay/F command cannot be executed, ETX is shifted to this position and only the end code is returned.

*2 When the response does not use data or when the specified FINS-mini command cannot be executed, ETX is shifted to this position.

9.6.7. Matrix Settings

This section describes the settings of the matrix. The MX PRO_R matrix is registered.



Additional Information

Refer to 3-5 *Creating Matrices* of the *CX-Protocol Operation Manual* (Cat. No. W344) for details on matrix settings.

<Matrix registration screen>

Matrix	Cases
MX PARA_R	3
MX PRO_R	4

*Four cases are set for the MX PRO_R matrix.

•Settings of MX PRO_R matrix

The following four cases are set: case No.00, case No.01, case No.02 and case No.15.

<Case setting screen>

Case Number	Receive Message	Next Process
00	RV PRO_R	End
01	RV FINSERR	End
02	RV COMFERR	End
15	Other	End

<Settings>

This table shows the settings of a receive message and next process for each case.

Case No.	Receive message	Next process
00	RV PRO_R	End
01	RV FINSERR	End
02	RV COMFERR	End
15	Other	End

*The matrix checks if the condition of each receive message is met in the following order: RV PRO_R (normal message), RV FINSERR and RV COMFERR (error message), and Other (other receive message). Then, it performs the process only for the condition that is met first. The ladder program checks the received result to detect an error in the destination device.

9.7. Timing Charts

The timing charts of the ladder program are shown below.

The definitions of the timing chart patterns are as follows:

Pattern	Normal end	Error end (1) PMCR instruction error	Error end (2) Communications error	Error end (3) Destination device error
Command	Normal	Error	Normal	Normal
Destination device	Normal	Normal or error	Normal or error	Error
Response	Yes	None	None	Yes

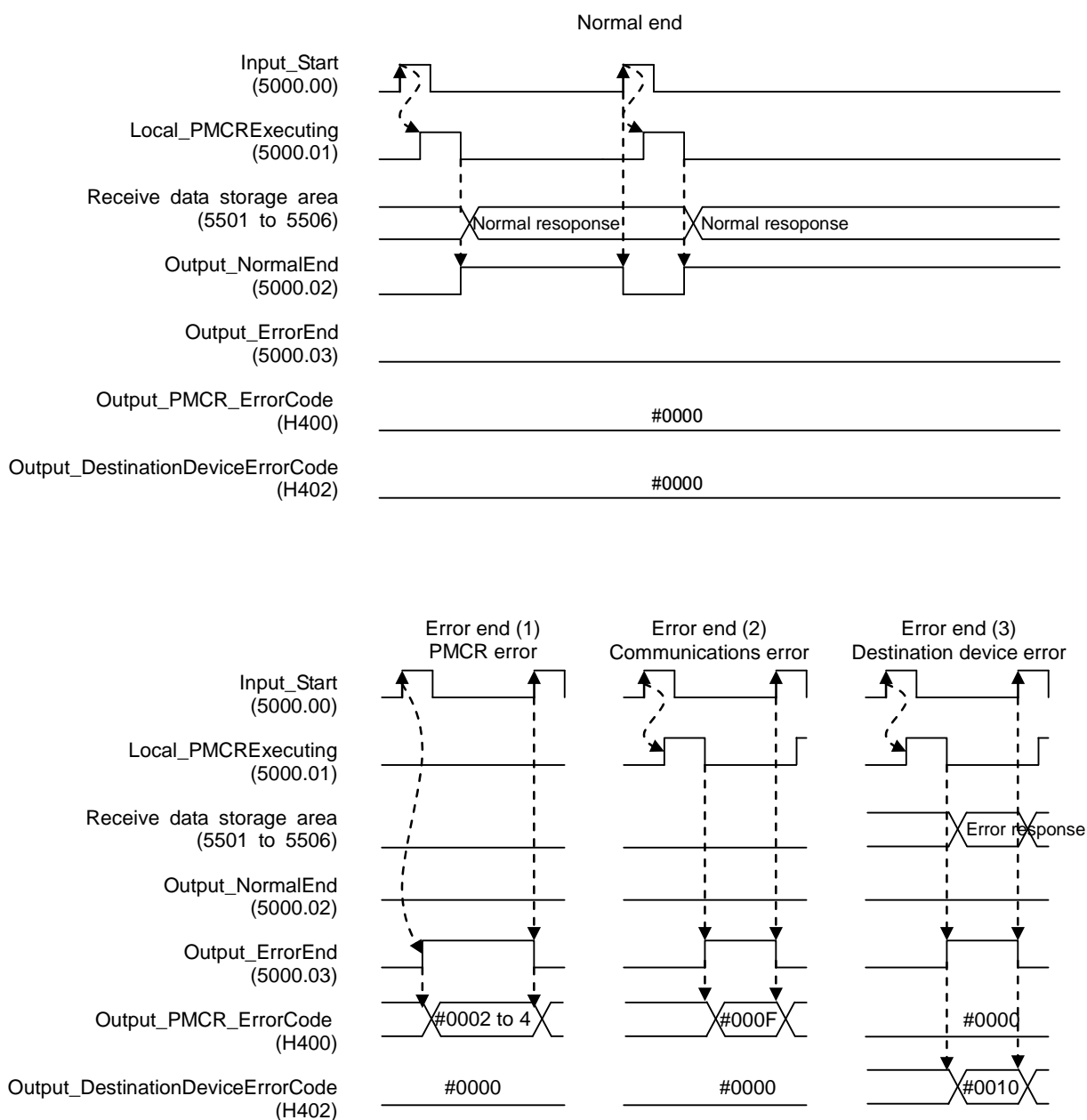

9.8. Error Process

The following tables list the errors that are generated by executing this program.

9.8.1. Protocol Macro Error Codes

The Serial Communications Unit detects these errors by monitoring the macro operations.

(1)The errors include (1) PMCR instruction error and (2) communications error (e.g., transmission error).

The error codes are stored in H400 (Output_PMCR_ErrorCode).

[Error code list]

Error code	Name	Classification	Description
#0002	Sequence No. error	(1)PMCR instruction error	The sequence number specified by the PMCR instruction does not exist in the Unit.
#0003	Symbol specification area exceeded error	(1)PMCR instruction error	When data is written to or read from the CPU Unit, the specified area range is exceeded.
#0004	Protocol data syntax error	(1)PMCR instruction error	A code that cannot be executed exists while the protocol macro is executed. (Example: A header exists after a terminator.)
#000F	Transmission error	(2)Communications error	Communications cannot be performed due to an error in the transmission path, etc.



Additional Information

For details and troubleshooting of the protocol macro errors, refer to *12-3 Troubleshooting of the CJ Series Serial Communications Boards and Serial Communications Units Operation Manual* (Cat. No. W336).

9.8.2. Destination Device Error Codes

The destination device errors are detected by monitoring the communications of the destination device when the Serial Communications Unit sends a command. The error code for the CompoWay/F error is stored in H402 (Output_DestinationDeviceErrorCode[0]) and the error code for the destination device support Fins-mini error is stored in H403 (Output_DestinationDeviceErrorCode[1]).

<Format> (H402)

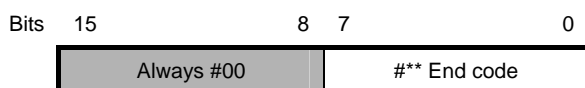

<End code list>

End code	Name	Description
00	Normal end	The command ended normally without error.
0F	Command error	When the specified command could not be executed, refer to the response code for details.
10	Parity error	A parity error occurred in a character when receiving.
11	Framing error	A framing error occurred in a character when receiving.
12	Overrun error	An overrun error occurred in a character when receiving.
13	BCC error	The BCC that was received is illegal.
14	Format error	The command text contains characters other than 0 to 9 and A to F.
16	Sub-address error	Illegal receive frame header or illegal address
18	Frame length error	The received frame exceeds the specified number of bytes.

[Format] (H403)

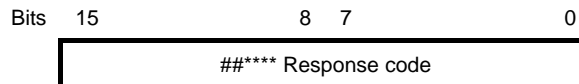

<Response code list>

Response code	Error name	Priority
0000	Normal end	None
0401	Unsupported command	1
1001	Command too long	2
1002	Command too short	3
1101	Area type error	4
1103	Start address out-of-range error	5
1003	Number of elements/data mismatch	6
110B	Response too long	7
1100	Parameter error	8
2203	Operation error	9



Additional Information

For details on the destination device errors and troubleshooting, refer to the *Smart Power Monitor KM50 Communications Manual* (Cat. No. N165) and *Section 5 Troubleshooting of the Smart Power Monitor KM50-E Operation Manual* (Cat. No. N164).

10. Revision History

Revision code	Date of revision	Revision reason and revision page
01	Feb. 5, 2013	First edition

OMRON Corporation Industrial Automation Company

Tokyo, JAPAN

Contact: www.ia.omron.com

Regional Headquarters

OMRON EUROPE B.V.

Wegalaan 67-69-2132 JD Hoofddorp
The Netherlands

Tel: (31)2356-81-300/Fax: (31)2356-81-388

OMRON ELECTRONICS LLC

One Commerce Drive Schaumburg,
IL 60173-5302 U.S.A.

Tel: (1) 847-843-7900/Fax: (1) 847-843-7787

OMRON ASIA PACIFIC PTE. LTD.

No. 438A Alexandra Road # 05-05/08 (Lobby 2),
Alexandra Technopark,
Singapore 119967

Tel: (65) 6835-3011/Fax: (65) 6835-2711

OMRON (CHINA) CO., LTD.

Room 2211, Bank of China Tower,
200 Yin Cheng Zhong Road,
PuDong New Area, Shanghai, 200120, China

Tel: (86) 21-5037-2222/Fax: (86) 21-5037-2200

Authorized Distributor:

© OMRON Corporation 201H All Rights Reserved.
In the interest of product improvement,
specifications are subject to change without notice.

Cat. No. P5(0-E1-01

0911(-)