

# MITSUBISHI

CC-Link - CC-Link/LT Bridge Module Type AJ65SBT-CLB

User's Manual

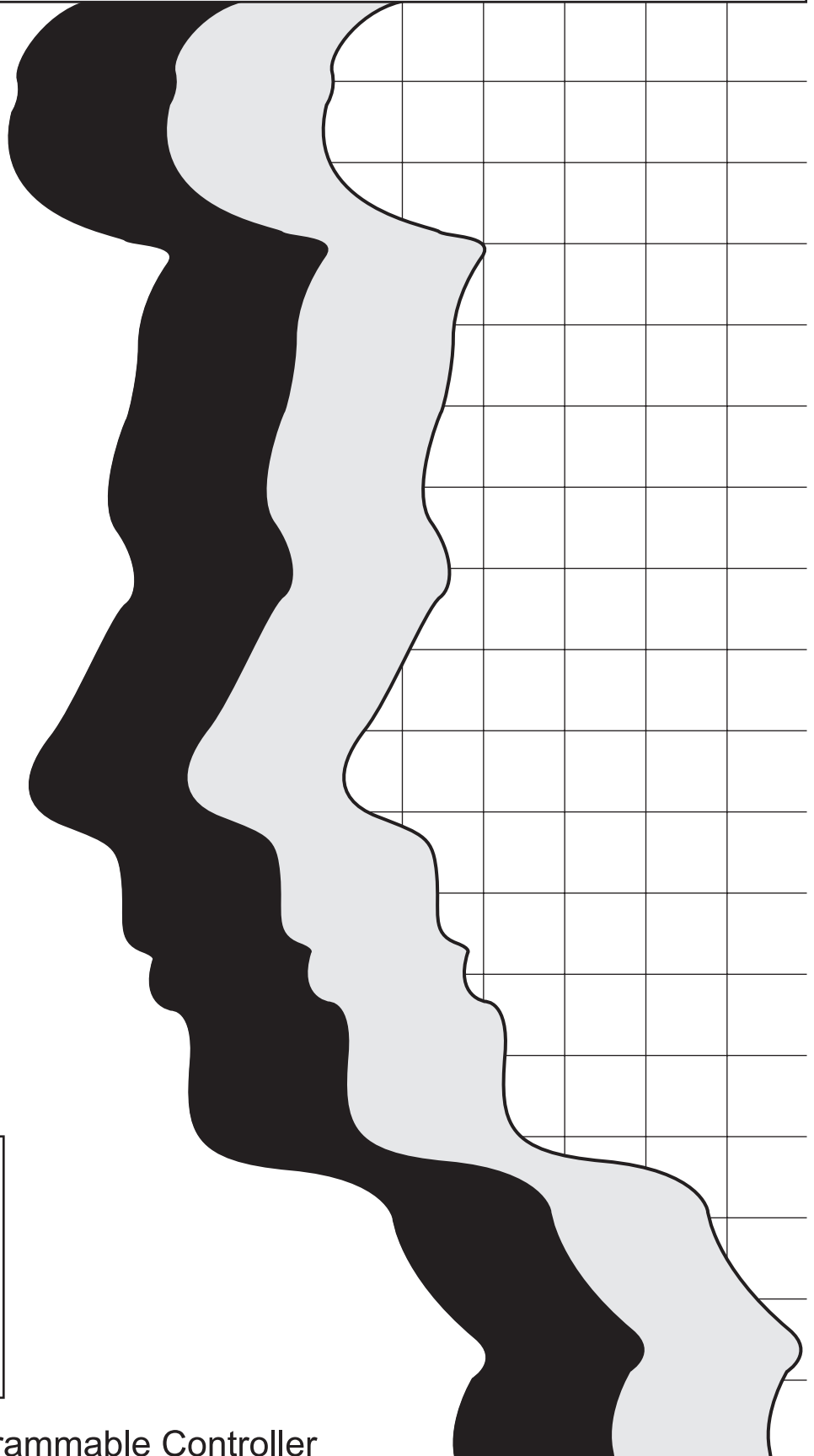

Mitsubishi Programmable Controller



## ● SAFETY PRECAUTIONS ●

(Be sure to read these instructions before using the product.)

Before using this product, read this manual and the relevant manuals introduced in this manual carefully and handle the product correctly with full attention to safety.

The precautions given in this manual are concerned with this product. For the safety precautions of the programmable controller system, please read the user's manual of the CPU module to use.

In this manual, the safety instructions are ranked as "DANGER" and "CAUTION".



**DANGER**

Indicates that incorrect handling may cause hazardous conditions, resulting in death or severe injury.



**CAUTION**

Indicates that incorrect handling may cause hazardous conditions, resulting in minor or moderate injury or property damage.

Note that the failure to observe  CAUTION level instructions may also lead to serious results according to the circumstances.

Be sure to observe the precautions of both levels to ensure personal safety.

Please keep this manual in accessible place and be sure to forward it to the end user.

### [Design Precautions]



**DANGER**

- When a communication error has occurred in data link, data in the master module are maintained.  
Establish an interlock circuit in the sequence program using communication status information so that the safety will be ensured.



**CAUTION**

- Do not bunch the control wires or communication cables with the main circuit or power wires, or install them close to each other.  
They should be installed 100mm (3.9inch) or more from each other.  
Not doing so could result in noise that would cause erroneous operation.
- Do not write data to "Reserved area" of remote I/O areas or remote devices.  
Doing so may cause malfunctions of the product.

## [Installation Precautions]

### CAUTION

- Use each product in an environment as specified in the "general specification" in this manual.  
Using the programmable controller outside the range of the general specifications may result in electric shock, fire or malfunction, or may damage or degrade the product.
- Securely fix the product with DIN rails or module mounting screws.  
Failure to do so may cause a fall or malfunctions of the product.
- Do not touch the conducted area or electric parts of the product.  
Doing so may cause product malfunctioning or breakdowns.

## [Wiring Precautions]

### CAUTION

- For application to the CC-Link/LT, use cables specified by the CC-Link Partner Association.  
Otherwise, performance of the CC-Link/LT cannot be guaranteed. Also, wire a network properly in accordance with the specifications given in Chapter 3.  
If not, normal data transmission cannot be guaranteed.
- Be sure to shut off all phases of the external power supply used by the system before installation or wiring.  
Not doing so can cause the product to be damaged or malfunction.
- Always ground the FG terminal to the protective ground conductor.  
Not doing so can cause a malfunction.
- Make sure of the rated voltage and pin-outs of the product for proper wiring.  
Connecting power source of improper rated voltage or faulty wiring may cause a fire or failure.
- Ensure that no foreign matter such as chips and wire-offcuts enter the product.  
Foreign matter can cause a fire, failure or malfunction.

## [Wiring Precautions]

### CAUTION

- Always secure the communication cable connected to the product by running it in a conduit or clamping it.  
Not doing so can cause damage to the product and/or cable due to the dangling, motion, careless pulling, etc. of the cable or cause a malfunction due to a faulty connection of the cable.
- When disconnecting the communication cable connected to the product, do not pull it by holding its cable part.  
When disconnecting the cable with connector, hold the connector of the product's connection part.  
Disconnect the terminal block connection cable after loosening the terminal block screws.  
Pulling the cable connected to the product can cause a malfunction or damage to the product and/or cable.

## [Starting and Maintenance Precautions]

### CAUTION

- Do not touch pins while the product is energized. Doing so may cause malfunctions.
- Be sure to shut off all phases of the external power supply used by the system before cleaning.
- Do not disassemble or modify the product.  
Doing so may cause failure, malfunctions, injury or fire.
- Do not drop the product or give it hard impact since its case is made of resin. Doing so can damage the product.
- Be sure to shut off all phases of the external power supply used by the system before mounting or dismounting the product to or from the panel.  
Not doing so can cause the product to fail or malfunction.
- Mounting/removing the terminal block is limited to 50 times after using a product.  
(IEC61131-2-compliant)
- Before handling the module, always touch grounded metal, etc. to discharge static electricity from the human body.  
Failure to do so can cause the module to fail or malfunction.

## [Disposal Precautions]

### CAUTION

- When disposing of this product, treat it as industrial waste.

REVISIONS

\* The manual number is given on the bottom left of the back cover.

Print Date	* Manual Number	Revision
Nov., 2002	SH(NA)-080362E-A	First printing
Feb., 2003	SH(NA)-080362E-B	<p>Addition</p> <p>Section 2.2.1, 6.7</p> <p>Correction</p> <p>Section 2.1, 2.3, 3.3.2, 3.6.2, 4.1, 4.5.2</p>
Jun., 2004	SH(NA)-080362E-C	<p>Addition</p> <p>Section 4.5.2, 4.5.3</p> <p>Correction</p> <p>Section 2.4, 3.2, 4.1, 4.5, 4.5.4, 4.7, 6.8</p>
Jan., 2005	SH(NA)-080362E-D	<p>Correction</p> <p>SAFETY PRECAUTIONS, Generic Terms and Abbreviations, Section 1.1, 1.2, 2.1, 2.2, 2.3, 3.2, 4.1, 4.2.1, 6.2, 6.6.4 to 6.6.8, 6.7, 6.8</p>
Mar., 2006	SH(NA)-080362E-E	<p>Correction</p> <p>Compliance with the EMC Directive and Low Voltage Directive, Section 2.3, 3.3.2, 3.4.5</p>
May, 2008	SH(NA)-080362E-F	<p>Correction</p> <p>Manuals, Compliance with the EMC Directive and Low Voltage Directive, Generic Terms and Abbreviations, Section 2.2, 3.7.1, 3.8.1, 3.9, 4.5.2, 4.6, 4.7.1, 6.2, 6.6.6</p>

Japanese Manual Version SH-080361-F

This manual confers no industrial property rights or any rights of any other kind, nor does it confer any patent licenses. Mitsubishi Electric Corporation cannot be held responsible for any problems involving industrial property rights which may occur as a result of using the contents noted in this manual.

© 2002 MITSUBISHI ELECTRIC CORPORATION

## INTRODUCTION

Thank you for purchasing the MELSEC-A series programmable controller. Before using the product, read this manual carefully to fully understand the functions and the performance of the programmable controller. Please forward a copy of this manual to the end user.

## CONTENTS

SAFETY PRECAUTIONS .....	A- 1
REVISIONS .....	A- 4
INTRODUCTION .....	A- 5
Manuals .....	A- 8
Compliance with the EMC Directive and Low Voltage Directive .....	A- 8
Generic Terms and Abbreviations .....	A- 9
Product List .....	A- 9

<b>1. OVERVIEW</b>	<b>1- 1 to 1- 2</b>
--------------------	---------------------

1.1 Overview .....	1- 1
1.2 Features .....	1- 2

<b>2. SYSTEM CONFIGURATION</b>	<b>2- 1 to 2- 8</b>
--------------------------------	---------------------

2.1 Overall Configuration .....	2- 1
2.2 Applicable System .....	2- 2
2.2.1 Applicable software package .....	2- 2
2.3 Precautions for System Configuration .....	2- 3
2.4 Parts Sold Separately .....	2- 7

<b>3. SPECIFICATIONS</b>	<b>3- 1 to 3-28</b>
--------------------------	---------------------

3.1 General Specifications .....	3- 1
3.2 Performance Specifications .....	3- 2
3.3 Network Wiring Specifications .....	3- 3
3.3.1 CC-Link network wiring specifications .....	3- 3
3.3.2 CC-Link/LT network wiring specifications .....	3- 3
3.4 Concept of Remote Input/Output .....	3- 5
3.5 Remote I/O Signals for CC-Link Master Module .....	3- 6
3.5.1 Remote I/O signal list when 2 stations are occupied .....	3- 6
3.5.2 Remote I/O signal list when 4 stations are occupied .....	3- 7
3.5.3 Remote I/O signal list when 8 stations are occupied (4 occupied stations×2 modules) .....	3- 8
3.5.4 Details of remote I/O signals .....	3- 9
3.6 Concept of the Number of Control Points (Point Mode Setting for CC-Link/LT and Number of Occupied Stations Setting for CC-Link) .....	3-15
3.6.1 Setting number of occupied stations .....	3-15
3.6.2 Setting point mode .....	3-15
3.7 Remote Registers .....	3-18
3.7.1 Assignment of remote registers .....	3-18

3.7.2 Last station number setting (common to 2, 4 and 8 occupied stations (4 occupied stations× 2 modules): Address RWwn) .....	3-20
3.7.3 Data link stop/restart instructions (common to 2, 4 and 8 occupied stations (4 occupied stations× 2 modules): Address RWwn+1).....	3-20
3.7.4 Error status flag clear (common to 2, 4 and 8 occupied stations (4 occupied stations× 2 modules): Address RWwn+2).....	3-20
3.7.5 Data of operating statuses (common to 2, 4 and 8 occupied stations (4 occupied stations× 2 modules): Address RWrn) .....	3-21
3.7.6 Data of faulty station (2 occupied stations: Address RWrn+1, common to 4 and 8 occupied stations (4 occupied stations×2 modules): Address RWrn+1, RWrn+2) .....	3-22
3.7.7 Remote I/O error data (2 occupied stations: Address RWrn+2, common to 4 and 8 occupied stations (4 occupied stations×2 modules): Address RWrn+3, RWrn+4) .....	3-23
3.7.8 Data of remote station connection (2 occupied stations: Address RWrn+3, common to 4 and 8 occupied stations (4 occupied stations×2 modules): Address RWrn+5, RWrn+6) .....	3-24
3.7.9 Setting data (2 occupied stations: Address RWrn+4, common to 4 and 8 occupied stations (4 occupied stations×2 modules): Address RWrn+7) .....	3-25
3.8 Data Link Processing Time.....	3-26
3.8.1 CC-Link link scan time .....	3-26
3.8.2 CC-Link/LT link scan time .....	3-26
3.9 Transmission Delay Time .....	3-27

<b>4. PROCEDURE UP TO DATA LINK</b>	<b>4- 1 to 4-23</b>
-------------------------------------	---------------------

4.1 Procedure Up to Data Link .....	4- 1
4.2 Mounting and Installation .....	4- 3
4.2.1 Handling precautions .....	4- 3
4.3 Part Names and Settings.....	4- 4
4.4 Facing Direction of the Module Installation .....	4- 7
4.5 Connecting Modules by CC-Link/LT Side Cables.....	4- 8
4.5.1 How to connect dedicated flat cable connector .....	4- 9
4.5.2 How to connect VCTF or high flexible cable connector .....	4-11
4.5.3 Mixture of different kinds of cables .....	4-14
4.5.4 Mounting terminating resistors.....	4-17
4.6 CC-Link Side Connection .....	4-18
4.6.1 Connection of the CC-Link dedicated cables .....	4-19
4.7 Wiring the One-Touch Connector Plug .....	4-20
4.8 Wiring Check .....	4-22
4.9 Maintenance and Inspection.....	4-23

<b>5. PROGRAMMING</b>	<b>5- 1 to 5-12</b>
-----------------------	---------------------

5.1 Conditions of Program Examples .....	5- 1
5.2 Program Example for Use of QCPU (Q Mode).....	5- 4
5.3 Program Example for Use of QnACPU .....	5- 6
5.4 Program Example for Use of ACPU/QCPU (A Mode) (Dedicated Instructions).....	5- 8
5.5 Program Example for Use of ACPU/QCPU (A Mode) (FROM/TO Instructions) .....	5-11



6. TROUBLESHOOTING	6- 1 to 6-19
--------------------	--------------

6.1 Station Status at Error Occurrence .....	6- 1
6.2 Troubleshooting Flow.....	6- 2
6.3 Troubleshooting when the "ERR" LED on the Master Station is Flashing.....	6- 3
6.4 Troubleshooting when the "PW" LED of the AJ65SBT-CLB has Turned Off .....	6- 5
6.5 CC-Link Side Troubleshooting.....	6- 6
6.5.1 Troubleshooting when the CC-Link side "L RUN" LED of the AJ65SBT-CLB has turned off .....	6- 6
6.5.2 Troubleshooting when the CC-Link side "L ERR." LED of the AJ65SBT-CLB is flickering.....	6- 7
6.6 CC-Link/LT Side Troubleshooting .....	6- 8
6.6.1 Troubleshooting when the CC-Link/LT side "L RUN" LED of the AJ65SBT-CLB has turned off...	6- 8
6.6.2 Troubleshooting when the CC-Link/LT side "L ERR." LED of the AJ65SBT-CLB has turned on/is flickering.....	6- 9
6.6.3 Troubleshooting when the CC-Link/LT side "ERR." LED of the AJ65SBT-CLB has turned on/is flickering.....	6-10
6.6.4 Troubleshooting when the "PW" LED of the CC-Link/LT remote I/O station has turned off .....	6-11
6.6.5 Troubleshooting when the "L RUN" LED of the CC-Link/LT remote I/O station has turned off .....	6-12
6.6.6 Troubleshooting when the "L ERR." LED of the CC-Link/LT remote I/O station has turned on/is flickering.....	6-13
6.6.7 Troubleshooting when input cannot be imported from the CC-Link/LT remote I/O station .....	6-14
6.6.8 Troubleshooting when output cannot be provided from the CC-Link/LT remote I/O station .....	6-15
6.7 CC-Link / CC-Link/LT Diagnostics Using GX Developer .....	6-16
6.8 Checking the Module Status (Self-loopback Test).....	6-19

APPENDIX	APP- 1 to APP- 4
----------	------------------

Appx 1 External Dimensions.....	APP- 1
Appx 2 I/O Assignment Sheet.....	APP- 2
Appx 2.1 I/O Assignment Sheet for 4-Point Mode Setting.....	APP- 2
Appx 2.2 I/O Assignment Sheet for 8-Point Mode Setting.....	APP- 3
Appx 2.3 I/O Assignment Sheet for 16-Point Mode Setting.....	APP- 4

INDEX	Index- 1 to Index- 2
-------	----------------------

## Manuals

The following manuals are also relevant to this product.

You can order them as necessary.

### **Relevant Manuals**

Manual Name	Manual Number (Model Code)
Control & Communication System Master/Local Module User's Manual type AJ61BT11/A1SJ61BT11 Describes the system configuration, performance specifications, functions, handling, wiring and troubleshooting of the AJ61BT11 and A1SJ61BT11. (Sold separately)	IB-66721 (13J872)
Control & Communication System Master/Local Module User's Manual type AJ61QBT11/A1SJ61QBT11 Describes the system configuration, performance specifications, functions, handling, wiring and troubleshooting of the AJ61QBT11 and A1SJ61QBT11. (Sold separately)	IB-66722 (13J873)
Control & Communication System Master/Local Module User's Manual type QJ61BT11N Describes the system configuration, performance specifications, functions, handling, wiring and troubleshooting of the QJ61BT11N. (Sold separately)	SH-080394E (13JR64)
Type A80BDE-J61BT11 Control & Communication Link System Master/Local Interface Board User's Manual (For SW4DNF-CCLINK-B) Describes the system configuration, performance specifications, handling, wiring and troubleshooting of the A80BDE-J61BT11. (Sold separately)	IB-0800175 (13JR28)
Type Q80BD-J61BT11N Control & Communication Link System Master/Local Interface Board User's Manual (For SW1DNC-CCBD2-B) Describes the system configuration, performance specifications, handling, wiring and troubleshooting of the A80BDE-J61BT11. (Sold separately)	SH-080527ENG (13JR77)

### Compliance with the EMC Directive and Low Voltage Directive

#### (1) For programmable controller system

To configure a system meeting the requirements of the EMC and Low Voltage Directives when incorporating the Mitsubishi programmable controller (EMC and Low Voltage Directives compliant) into other machinery or equipment, refer to the "EMC AND LOW VOLTAGE DIRECTIVES" chapter of the User's Manual for the CPU module used.

The CE mark, indicating compliance with the EMC and Low Voltage Directives, is printed on the rating plate of the programmable controller.

#### (2) For the product

For the compliance of this product with the EMC and Low Voltage Directives, refer to the "CC-Link module" section in the "EMC AND LOW VOLTAGE DIRECTIVES" chapter of the User's Manual for the CPU module used.

Generic Terms and Abbreviations

Unless otherwise specified, this manual uses the following generic terms and abbreviations.

Generic Term/Abbreviation	Description
AJ65SBT-CLB	Abbreviation for AJ65SBT-CLB CC-Link - CC-Link/LT bridge module.
GX Developer	Generic product name for the product types SWnD5C-GPPW-E, SWnD5C-GPPW-EA, SWnD5C-GPPW-EV and SWnD5C-GPPW-EVA. (n indicates any of Versions 0 to 7)
Master module	Station that controls data link system. One master station is required for each system.
Remote I/O module	Remote module that handles bit unit data only. (Performs input and output with external devices.)
Remote device module	Remote module that handles bit unit and word unit data only. (Performs input and output with external devices, and analog data conversion.)
Remote module	Generic term for remote I/O module and remote device module.
Remote I/O station	Remote station that handles bit unit data only. (Performs input and output with external devices.)
Remote device station	Remote station that handles bit unit and word unit data only. (Performs input and output with external devices, and analog data conversion.)
Remote station	Generic term for remote I/O station and remote device station.
Intelligent device station	Station that can perform transient transmission, such as the AJ65BT-R2N (including local stations).
Dedicated power supply	Module connected for power supply to CC-Link/LT system. At least one dedicated power supply or power supply adapter is required for a system.
Power supply adapter	
RX	Remote input (for CC-Link) Information input in bit unit from the remote station to the master station. (Represented as RX)
RY	Remote output (for CC-Link) Information output in bit unit from the master station to the remote station. (Represented as RY)
RWw	Remote register (Write area for CC-Link) Information output in 16-bit unit from the master station to the remote device station. (Represented as RWw)
RWr	Remote register (Read area for CC-Link) Information input in 16-bit unit from the remote device station to the master station. (Represented as RWr)

Product List

This product consists of the following.

Model name	Product Name	Quantity
AJ65SBT-CLB	AJ65SBT-CLB CC-Link - CC-Link/LT Bridge Module	1

1 OVERVIEW

1

This manual provides the specifications, part names, setting, etc. of the AJ65SBT-CLB CC-Link - CC-Link/LT bridge module (hereafter referred to as the AJ65SBT-CLB) that is designated to be used as a remote device station in a CC-Link system.

1.1 Overview

The AJ65SBT-CLB includes the bridge function to establish a connection between CC-Link and CC-Link/LT.

Using the AJ65SBT-CLB connects the remote I/O of CC-Link/LT to a CC-Link system. Any of the A series, QnA series and Q series can be used to configure a system, realizing a compact wire-saving system.

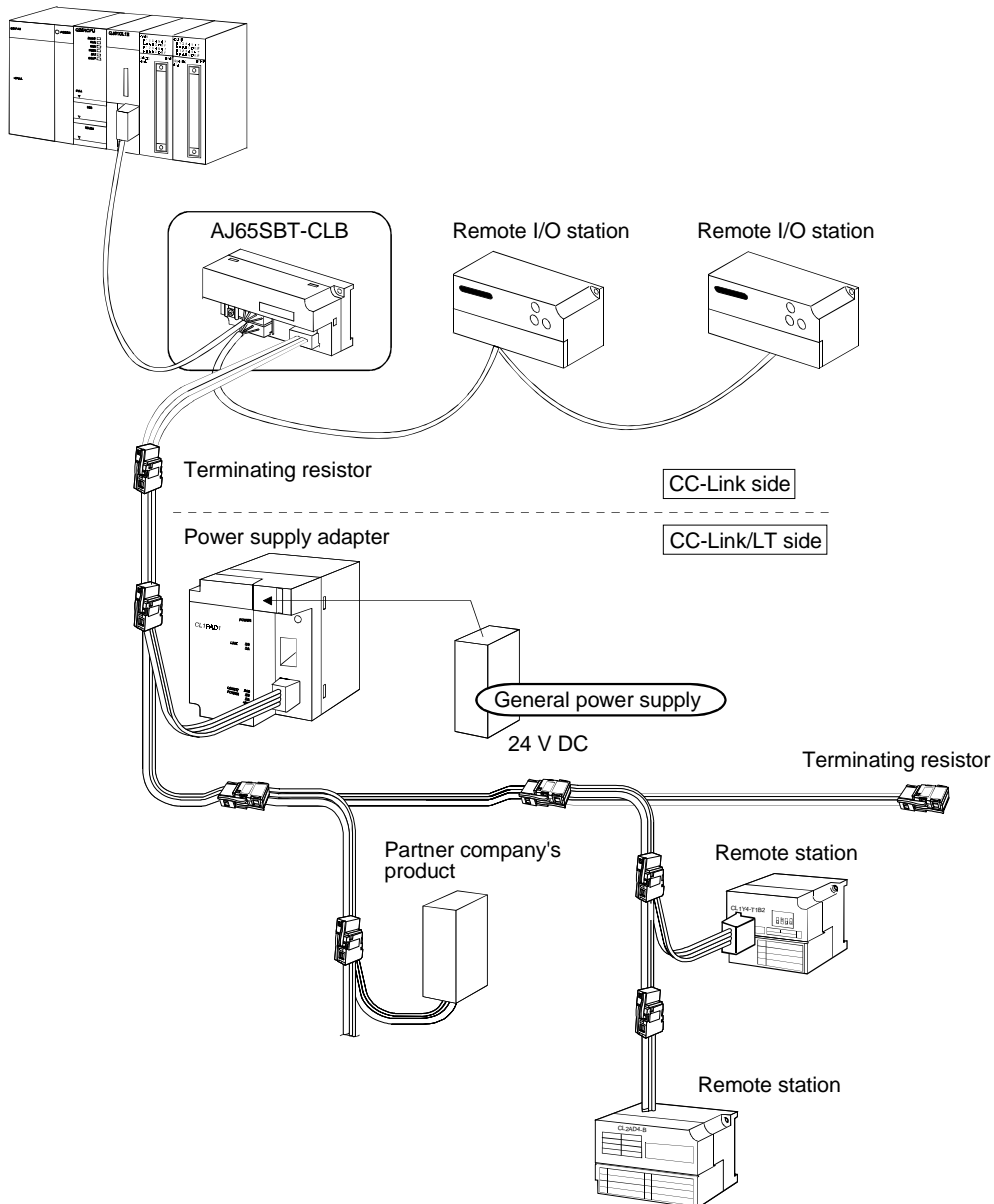

## 1.2 Features

The AJ65SBT-CLB has the following features.

(1) **Seamless connection of two networks**

The AJ65SBT-CLB is a bridge module that can connect CC-Link and CC-Link/LT seamlessly.

Using RX and RY (bit devices), one bridge module can control up to 224 points (448 points when both inputs and outputs are used).

(2) **Confirmation of communication status of CC-Link/LT remote stations**

The data link statuses and I/O errors of CC-Link/LT remote stations can be confirmed from the PLC CPU of the CC-Link master station.

(3) **Configuration of CC-Link/LT using A, QnA series**

A CC-Link/LT system can be configured using the MELSEC-A, QnA series via CC-Link.

(4) **Wire saving and easy installation**

The one-touch connectors ensure easy installation by using as the CC-Link side communication connectors.

(5) **Compact size**

The AJ65SBT-CLB has the same size as the AJ65SBTB1-8□ compact remote I/O module.

(Width 87.0 (3.43) × height 49.0 (1.93) × depth 40.0 (1.57) mm (inch))

Either of screws or DIN rail can be used to mount the module to a control panel.

## 2 SYSTEM CONFIGURATION

### 2.1 Overall Configuration

This section explains a system including the AJ65SBT-CLB.  
 For the transmission specifications, station-to-station distance, overall cable distance (maximum transmission distance), etc. of CC-Link, refer to the user's manual of the master module.  
 Refer to Section 3.3 for the wiring specifications.

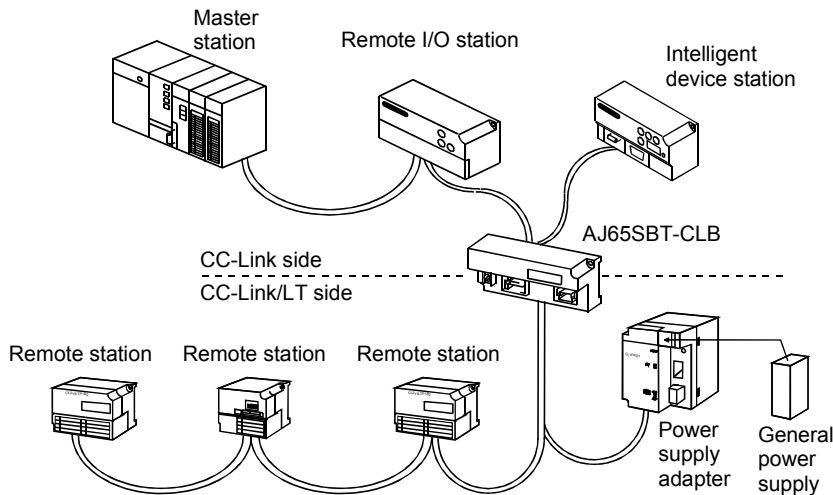
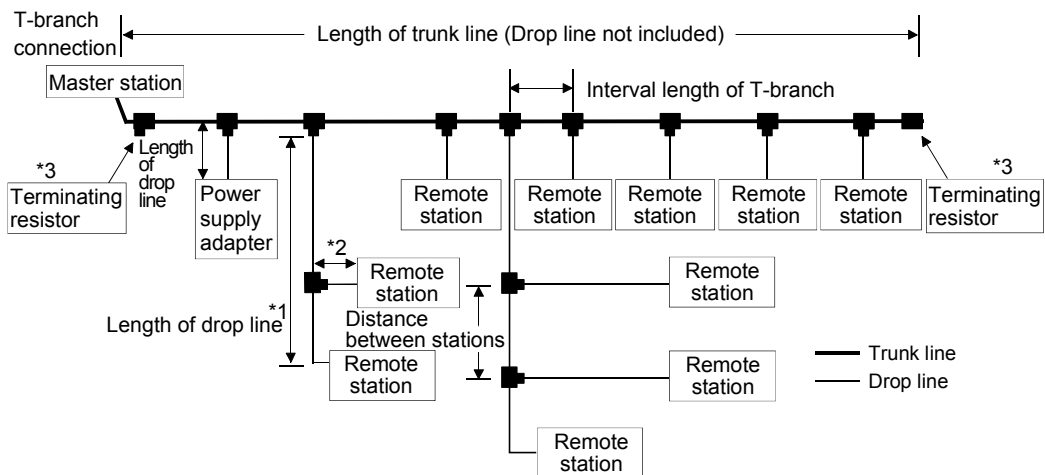

Table 2.1 Network Wiring Specifications

Item	Specifications			Remarks
	2.5 Mbps	625 kbps	156 kbps	
Transmission speed	2.5 Mbps	625 kbps	156 kbps	—
Station-to-station distance	Not limited			—
Max. no. of modules per drop line	8 modules			—
Length of trunk line	35 m	100 m	500 m	Cable length between terminating resistors. Length of drop lines not included
T-branch interval	Not limited			—
Max. length of drop line	4 m	16 m	60 m	Max. cable length for one branch line
Overall length of drop lines	15 m	50 m	200 m	Total length of all drop lines



\*1: The length of the drop line includes the length of \*2. (The max. length of drop line and overall length of drop lines include the length of \*2.)  
 \*2: Distance between stations.  
 \*3: Refer to Section 4.5.4 for the terminating resistor mounting method.

POINT
(1) The connection order of remote stations is not relevant to the station numbers.
(2) The remote station numbers are not necessarily consecutive. (Empty station number does not cause data link failure.)

## 2.2 Applicable System

2

This section explains the applicable master modules and the precautions for system configuration.

(1) The following table indicates the applicable master modules.

	Model Name
Q series	QJ61BT11N, QJ61BT11
QnA series	AJ61QBT11, A1SJ61QBT11
A series	AJ61BT11, A1SJ61BT11
FX series	FX <sub>2N</sub> -16CCL-M *
PCI board	Q80BD-J61BT11N, A80BD-J61BT11
Others	CC-Link partner maker's master module

\* The FX series can be used within the range of:  
 FX<sub>1N</sub>, FX<sub>1NC</sub> ≤ 128 points  
 FX<sub>2N</sub>, FX<sub>2NC</sub> ≤ 256 points  
 in the whole system.

### 2.2.1 Applicable software package

To carry out CC-Link / CC-link/LT diagnostics, GX Developer of Version 8.00A or later is required.

2.3 Precautions for System Configuration

(1) Arrangement of AJ65SBT-CLB

(a) CC-Link side

The AJ65SBT-CLB can be placed in any position as the remote device station of the CC-Link system.

(b) CC-Link/LT side

Since T-branch connection can be made, the AJ65SBT-CLB can apparently be placed midway through the trunk line. Note that the length of the trunk line is defined as the length between two terminating resistors.

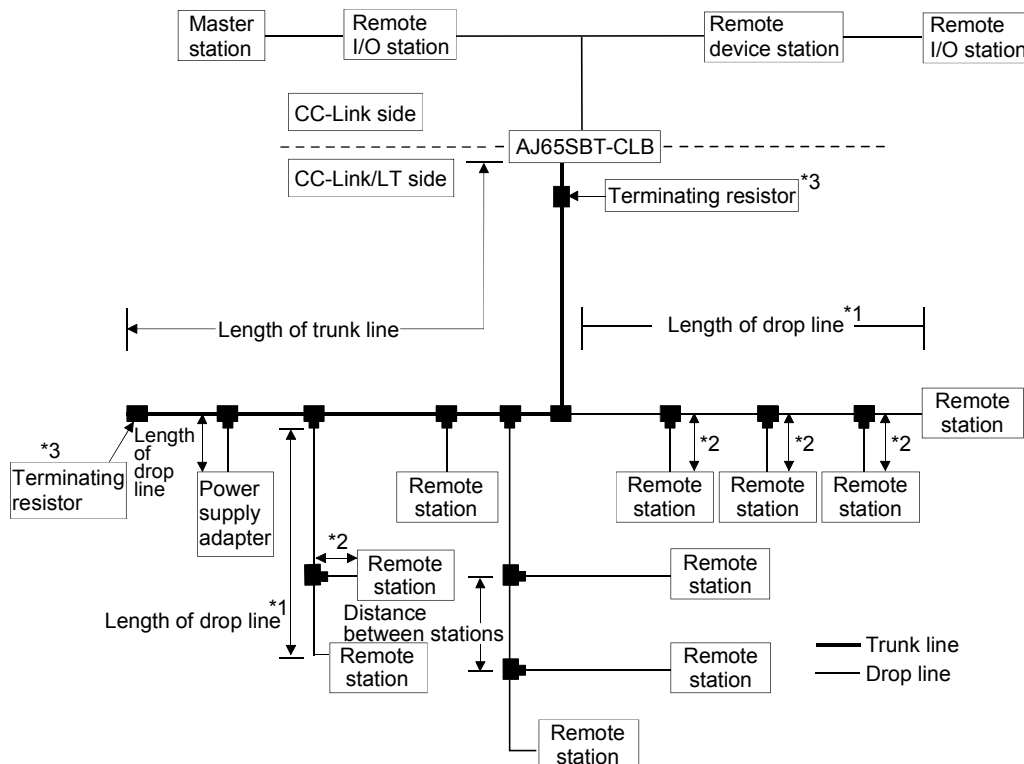

\*1 The length of drop line includes the length of \*2. (The max. length of drop line and overall length of drop lines include the length of \*2.)

\*3 Refer to Section 4.5.4 for the terminating resistor mounting method.

(2) Number of CC-Link/LT side drop line branch stages

In the CC-Link/LT system, branch the drop line up to two stages. The drop line cannot be branched to three or more stages.

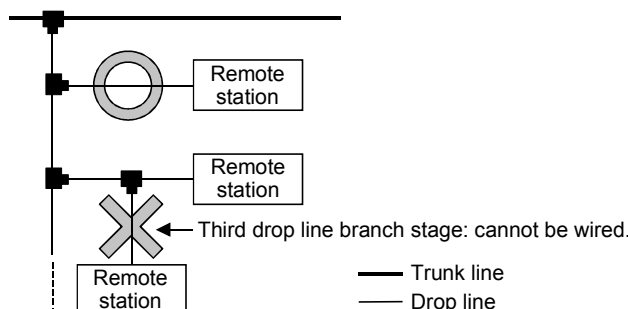



(3) Mounting condition for CC-Link/LT dedicated power supply or power supply adaptor

The mounting conditions for a dedicated power supply or power supply adapter for the CC-Link/LT vary depending on the devices to be connected and the wiring length.

Refer to the User's Manual of the dedicated power supply or power supply adapter for the conditions.

**POINT**

Always connect the dedicated power supply or power supply adapter to the trunk line. (Connection to branch lines is not allowed.)

(4) Prevention of incorrect input/output from remote I/O module of CC-Link/LT

To prevent incorrect input/output from remote I/O modules, design the system while paying full attention to the following.

(a) When power is ON or OFF

Power ON the remote I/O module (Power on the dedicated power supply or power supply adapter) before starting the data link.

Also, stop the data link before powering OFF the remote I/O module (Powering off the dedicated power supply or power supply adapter).

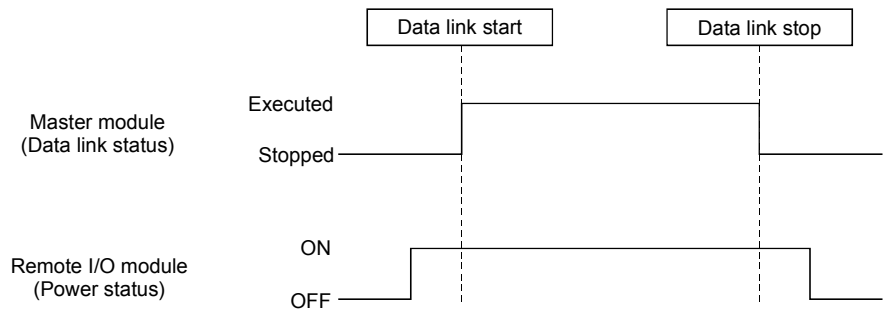

(b) Instantaneous power failure of remote I/O module

When instantaneous power failure occurs in the power source (24V DC) for the remote I/O module, incorrect data may be input.

1) Causes of incorrect input due to instantaneous power failure

The hardware of the remote I/O module converts the supplied power of 24V DC into 5V DC inside the module and uses it for its own operation. When instantaneous power failure occurs in the remote I/O module, the following,

(Time until 5V DC is turned OFF inside the remote I/O module)

>(Response time from ON to OFF of the input ), is established.

Therefore, when the devices are refreshed within the time shown as (1), data will be incorrectly input. (Especially, when the input response time is set to the high-speed response type)

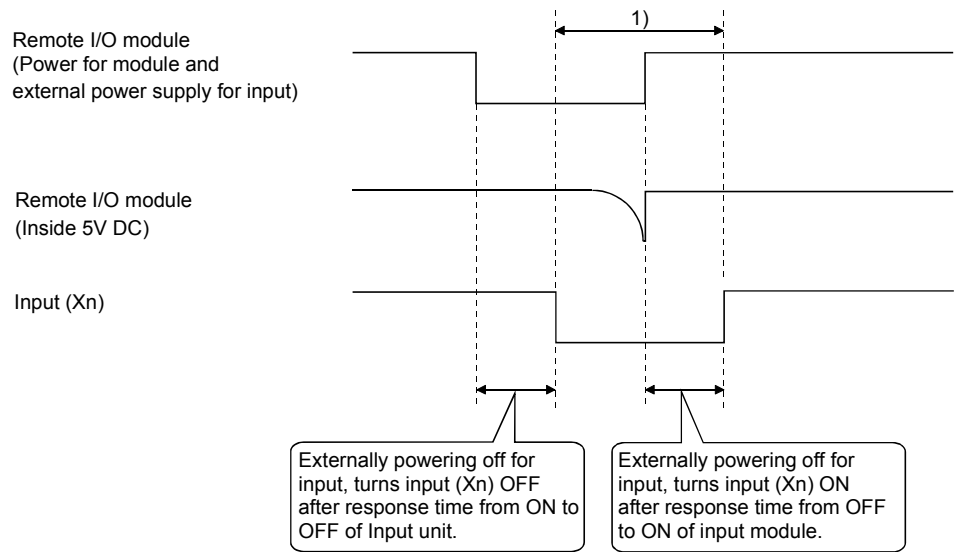

2) Preventive measure against incorrect input

Install wiring so that the power is supplied from the same power source to the power supply module, stabilized power supply and external power supply for AC input.

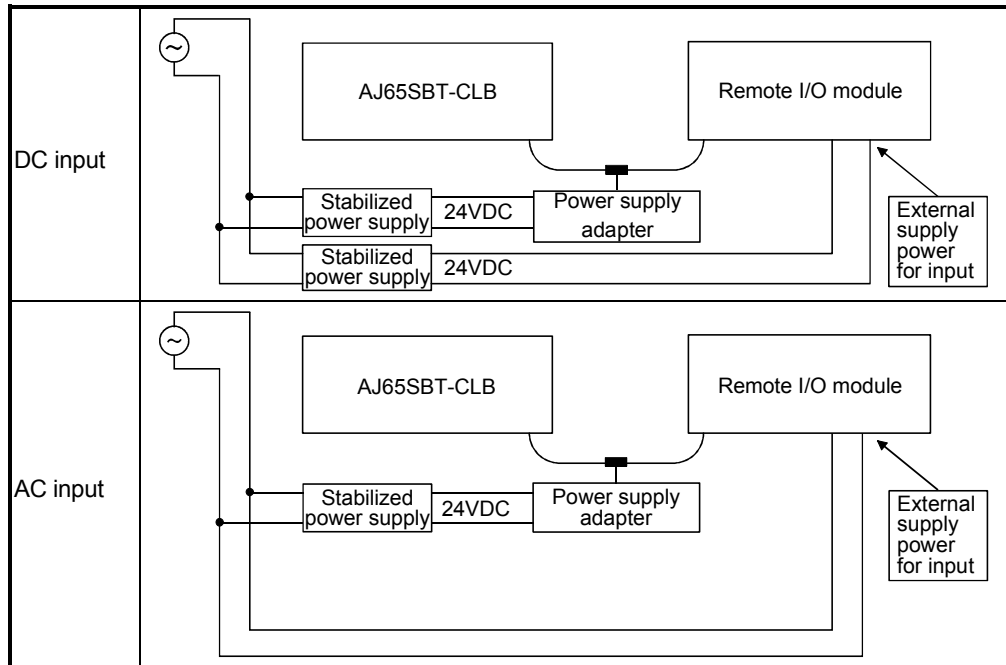

2.4 Parts Sold Separately

The plugs for AJ65SBT-CLB are sold separately.  
Please purchase them as necessary.

	Mitsubishi model name	Part model name (manufacturer)	Specifications			Color of the cover
			communication line 0.5 (AWG#20)	$\phi$ 2.2 to 3.0		
One-touch connector plug for communication *1, *2	A6CON-L5P	35505-6000-BOM GF (3M)	communication line 0.5 (AWG#20)	$\phi$ 2.2 to 3.0		Red
			shielded cable (drain wire) 0.5 (AWG#20)			
Online connector for communication *3	A6CON-LJ5P	35720-L200-B00 AK (3M)	—	—	—	—
One-touch connector plug with terminating resistor (including 1)	A6CON-TR11	—	One-touch connector plug with terminating resistor attached for communication (110 $\Omega$ )	—	—	—

- \*1 Mitsubishi's A6CON-□5P includes 10 plugs.
- \*2 Once insulation-displaced, the one-touch connector plugs cannot be reused.
- \*3 Mitsubishi's A6CON-□J5P includes 5 plugs.

**REMARK**

- As following table indicates, the optional plugs/connectors are compatible with the connectors for this module.

Connector for this Module	Optional Parts
One-touch connector for communication	<ul style="list-style-type: none"> <li>• One-touch connector plug for communication</li> <li>• Online connector for communication</li> <li>• One-touch connector plug with terminating resistor</li> </ul>

- Cables, connectors and terminating resistors on the CC-Link/LT side  
For inquiries about the cables, connectors and/or terminating resistors on the CC-Link/LT side, access the home page of the CC-Link Partner Association on the Internet at <http://www.cc-link.org/>.



## 3 SPECIFICATIONS

This chapter provides the specifications of the AJ65SBT-CLB.

## 3.1 General Specifications

Table 3.1 General specifications

Item	Specifications					
Operating ambient temperature	0 to 55°C					
Storage ambient temperature	-25 to 75°C					
Operating ambient humidity	5 to 95%RH, non-condensing					
Storage ambient humidity	5 to 95%RH, non-condensing					
Vibration resistance	Conforming to JIS B 3502, IEC 61131-2		Frequency	Acceleration	Amplitude	Sweep count  10 times each in X, Y, Z directions (for 80 min.)
		Under intermittent vibration	10 to 57Hz	—	0.075mm (0.003inch)	
			57 to 150Hz	9.8m/s <sup>2</sup>	—	
		Under continuous vibration	10 to 57Hz	—	0.035mm (0.001inch)	
57 to 150Hz	4.9m/s <sup>2</sup>		—			
Shock resistance	Conforming to JIS B 3502, IEC 61131-2 (147 m/s <sup>2</sup> , 3 times in each of 3 directions X, Y, Z)					
Operating ambience	No corrosive gases					
Operating altitude	2000m (6562ft.) max.					
Installation location	Inside control panel					
Overvoltage category *1	II max.					
Pollution degree *2	2 max.					

\*1 : This indicates the section of the power supply to which the equipment is assumed to be connected between the public electrical power distribution network and the machinery within premises. Category II applies to equipment for which electrical power is supplied from fixed facilities.

The surge voltage withstand level for up to the rated voltage of 300 V is 2500 V.

\*2 : This index indicates the degree to which conductive material is generated in terms of the environment where the equipment is used.

Pollution level 2 is when only non-conductive pollution occurs but temporary conductivity may be produced due to condensation.

\*3 : Do not use or store the programmable controller under pressure higher than the atmospheric pressure of altitude 0m.

Doing so can cause a malfunction.

When using the programmable controller under pressure, please contact your sales representative.

3.2 Performance Specifications

The following table provides the performance specifications of the AJ65SBT-CLB.

Table 3.2 Performance specifications

Item		Specifications			
CC-Link side	Station type	Remote device station			
	CC-Link Version	Ver.1.10			
	Number of occupied stations	2 stations	64 points each for RX and RY (16 points are used in the system) 8 points each for RWr and RWw		
		4 stations	128 points each for RX and RY (16 points are used in the system) 16 points each for RWr and RWw		
		8 stations (4 occupied stations × 2 modules)	256 points each for RX and RY (32 points are used in the system) 32 points each for RWr and RWw		
	AJ65SBT-CLB connection position	No restrictions			
External connection system	One-touch connector for communication [transmission circuit] (5-pin, insulation displacement type connector plug is sold separately) <Sold separately> Online connector for communication: A6CON-LJ5P				
CC-Link/LT side			4-point mode	8-point mode	16-point mode
	Control specifications	Maximum number of link points Number in parentheses assumes use of the same I/O addresses	224 points (448 points)		
		Number of link points per station Number in parentheses assumes use of the same I/O addresses	4 points (8 points)	8 points (16 points)	16 points (32 points)
	Communication specifications	Transmission speed	2.5Mbps/625kbps/156kbps		
		Communication system	BITR system (Broadcastpolling + Interval Timed Response)		
		Transmission path format	T-branch system		
		Error control system	CRC		
		Number of connected modules	56 modules		
		Remote station number	1 to 56		
		AJ65SBT-CLB connection position	Connected at the end of the trunk line		
RAS functions		Network diagnostics, internal loopback diagnostics, slave station separation, automatic return to system			
Connection cable*1	Dedicated flat cable (0.75mm <sup>2</sup> X4)*4, VCTF cable*3, high flexible cable*4				
Common	Module mounting screw	M4 × 0.7mm × 16mm or more screw Tightening torque range 78 to 108N · cm DIN rail can also be used for mounting.			
	Module mounting direction	Can be mounted in any of six orientations. (No restrictions on mounting directions)			
	24V DC power supply*2	Voltage	24V DC externally supplied (20.4V DC to 26.4V DC, ripples within 5%)		
		Current consumption	0.075A (When 24V DC)		
		Start-time current	0.165A (When 24V DC)		
	Level of protection	IP2X			
Weight	0.09kg				

\*1 Performance of the CC-Link/LT cannot be guaranteed for use of cables other than the dedicated flat cables, VCTF cables and high flexible cables.

\*2 Supplied by the dedicated power supply or power supply adaptor of CC-Link/LT.

\*3 For VCTF cable specifications, see Table 3.3.

\*4 Use the dedicated flat cables and high flexible cables accredited by the CC-Link Partner Association. (Refer to Section 2.4.)



Table 3.3 VCTF cable specifications (Extract from JIS C 3306)

Type	No. of cores	Conductor			Insulator thickness	Sheath thickness	Conductor resistance (20 °C)
		Nominal cross-sectional area	Composition No. of wires/wire diameter	Outside diameter			
Vinyl cabtyre, Round cord	4	0.75mm <sup>2</sup>	30/0.18mm	1.1mm	0.6mm	1.0mm	25.1 Ω/km

### 3.3 Network Wiring Specifications

#### 3.3.1 CC-Link network wiring specifications

For the network wiring specifications of CC-Link, refer to the user's manual of the master module.

#### 3.3.2 CC-Link/LT network wiring specifications

The following indicates the network wiring specifications of CC-Link/LT.

Item	Specifications			Remarks
	2.5 Mbps	625 kbps	156 kbps	
Transmission speed	2.5 Mbps	625 kbps	156 kbps	—
Distance between stations	Not limited			—
Max. no. of connectable modules per drop line	8 modules			—
Length of trunk line	35 m	100 m	500 m	Cable length between terminating resistors. Length of drop lines not included
T-branch interval	Not limited			—
Max. length of drop line	4 m	16 m	60 m	Max. cable length per branch line
Overall length of drop lines	15 m	50 m	200 m	Total length of all drop lines

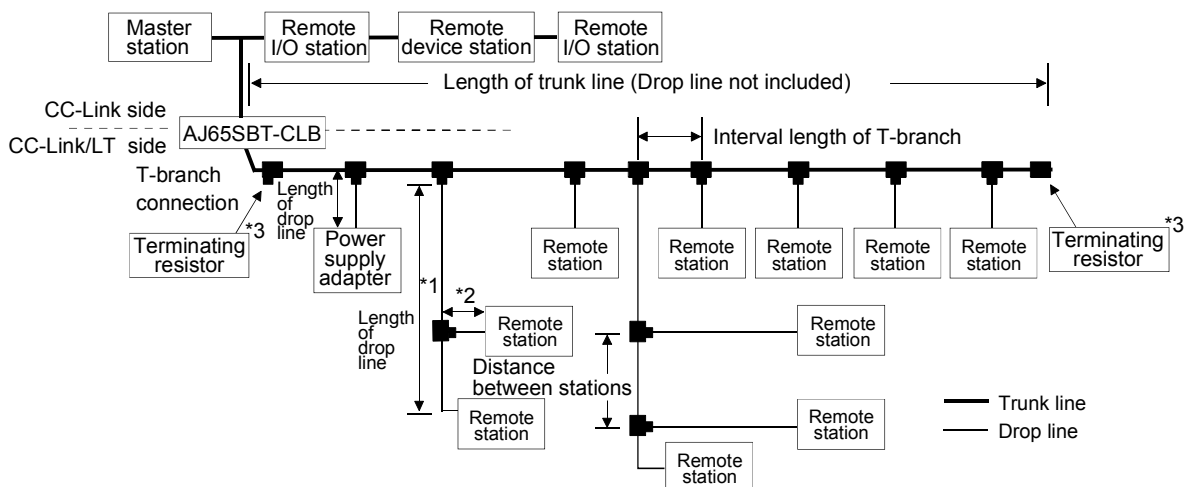

\*1 The length of drop line includes the length of \*2. (The max. length of drop line and overall length of drop lines include the length of \*2.)

\*3 Refer to Section 4.5.4 for the terminating resistor mounting method.





### 3.4 Concept of Remote Input/Output

This section explains the I/O signals for the AJ65SBT-CLB module.

Example: The following provides an example of setting the AJ65SBT-CLB to 2 occupied stations and 4-point mode.

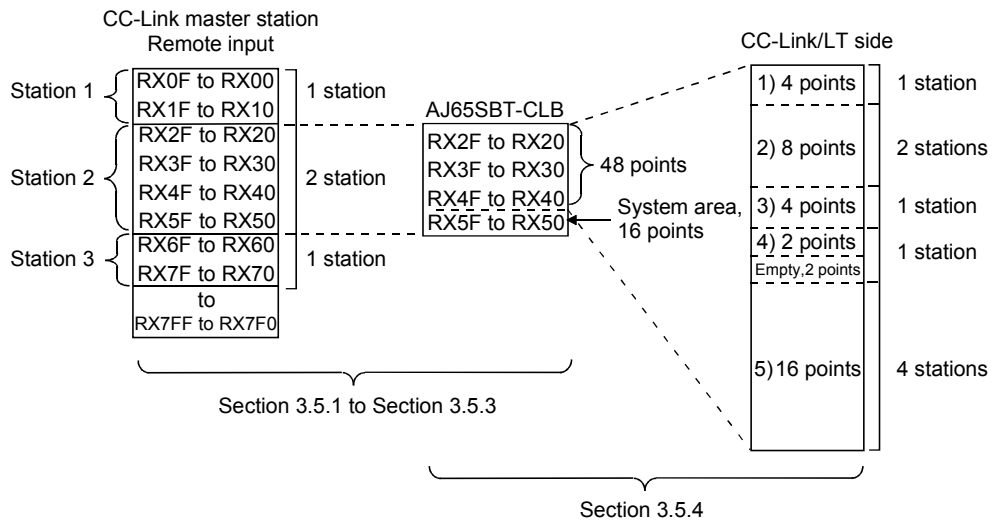
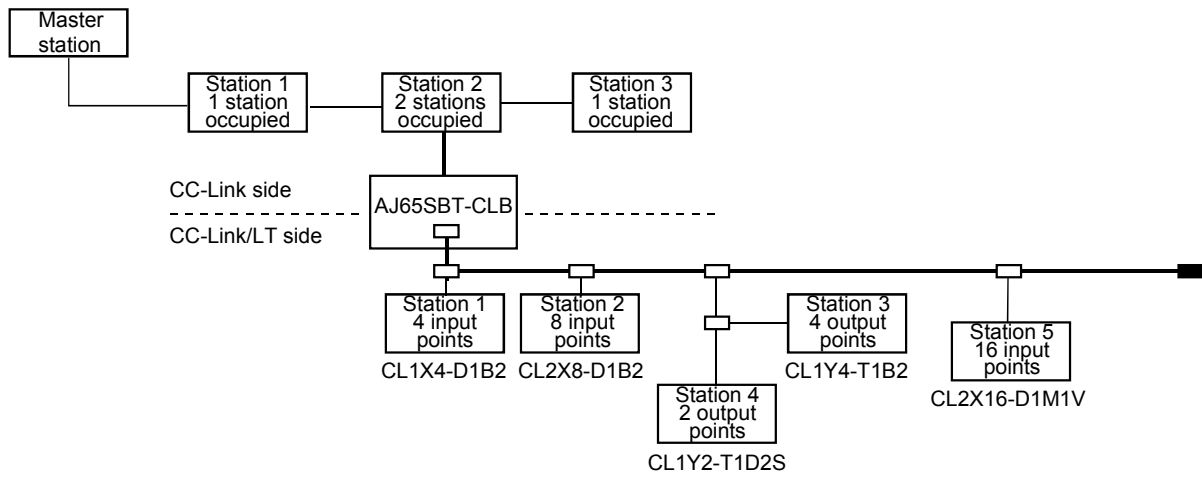

3.5 Remote I/O Signals for CC-Link Master Module

This section explains the I/O signals of the AJ65SBT-CLB for the CC-Link master module.

3.5.1 Remote I/O signal list when 2 stations are occupied

Out of 64 points, 16 points are used as a system area.

Signal Direction: AJ65SBT-CLB → master module		Signal Direction: Master module → AJ65SBT-CLB	
Remote input (RX)	Name	Remote output (RY)	Name
RXn0 to RX(n+2)F	Used by CC-Link/LT remote	RYn0 to RY(n+2)F	Used by CC-Link/LT remote
RX(n+3)0 to RX(n+3)9	Use prohibited	RY(n+3)0 to RY(n+3)F	Use prohibited
RX(n+3)A	Error status flag		
RX(n+3)B	Remote READY		
RX(n+3)C	Use prohibited		
RX(n+3)D			
RX(n+3)E			
RX(n+3)F			

<b>POINT</b>
<p>The prohibited devices are used by the system and therefore cannot be used by the user.</p> <p>If data is written to the buffer memory area corresponding to the prohibited device or to the device specified for auto refresh, the functions of the AJ65SBT-CLB cannot be guaranteed.</p>

3.5.2 Remote I/O signal list when 4 stations are occupied

Out of 128 points, 16 points are used as a system area.

Signal Direction: AJ65SBT-CLB → Master module		Signal Direction: Master module → AJ65SBT-CLB	
Remote input (RX)	Name	Remote output (RY)	Name
RXn0 to RX(n+6)F	Used by CC-Link/LT remote	RYn0 to RY(n+6)F	Used by CC-Link/LT remote
RX(n+7)0 to RX(n+7)9	Use prohibited	RY(n+7)0 to RY(n+7)F	Use prohibited
RX(n+7)A	Error status flag		
RX(n+7)B	Remote READY		
RX(n+7)C	Use prohibited		
RX(n+7)D			
RX(n+7)E			
RX(n+7)F			

<b>POINT</b>
<p>The prohibited devices are used by the system and therefore cannot be used by the user.</p> <p>If data is written to the buffer memory area corresponding to the prohibited device or to the device specified for auto refresh, the functions of the AJ65SBT-CLB cannot be guaranteed.</p>

3.5.3 Remote I/O signal list when 8 stations are occupied (4 occupied stations × 2 modules)

Out of 256 points, 32 points are used as a system area.

When 8 stations (4 occupied stations × 2 modules) are occupied, two 4-station occupying modules are placed in series.

Signal Direction: AJ65SBT-CLB → Master module		Signal Direction: Master module → AJ65SBT-CLB	
Remote input (RX)	Name	Remote output (RY)	Name
RXn0 to RX(n+6)F	Used by CC-Link/LT remote	RYn0 to RY(n+6)F	Used by CC-Link/LT remote
RX(n+7)0 to RX(n+7)9	Use prohibited	RY(n+7)0 to RY(n+7)F	Use prohibited
RX(n+7)A	Error status flag		
RX(n+7)B	Remote READY		
RX(n+7)C	Use prohibited		
RX(n+7)D			
RX(n+7)E			
RX(n+7)F			
RX(n+8)0 to RX(n+E)F	Used by CC-Link/LT remote	RY(n+8)0 to RY(n+E)F	Used by CC-Link/LT remote
RX(n+F)0 to RX(n+F)9	Use prohibited	RY(n+F)0 to RY(n+F)F	Use prohibited
RX(n+F)A	Error status flag		
RX(n+F)B	Remote READY		
RX(n+F)C	Use prohibited		
RX(n+F)D			
RX(n+F)E			
RX(n+F)F			

**POINT**

- The prohibited devices are used by the system and therefore cannot be used by the user.  
If data is written to the buffer memory area corresponding to the prohibited device or to the device specified for auto refresh, the functions of the AJ65SBT-CLB cannot be guaranteed.
- Set the station data as two modules that occupy four remote device stations.
- The same data is stored into "RXn+7A, RXn+7B" and "RXn+FA, RXn+FB".

3.5.4 Details of remote I/O signals

This section explains the assignment and functions of the CC-Link remote inputs/outputs.

(1) Remote I/O signal list for 4-point mode setting

(a) The following table lists the I/O signals for 2 occupied station setting

Remote input (RX) of CC-Link	Remote input (X) of CC-Link/LT															
	F	E	D	C	B	A	9	8	7	6	5	4	3	2	1	0
RXnF to RXn0	Station number 4				Station number 3				Station number 2				Station number 1			
to	to															
RX(n+2)F to RX(n+2)0	Station number 12				Station number 11				Station number 10				Station number 9			
RX(n+3)F to RX(n+3)0	Use prohibited															

Remote output (RY) of CC-Link	Remote output (Y) of CC-Link/LT															
	F	E	D	C	B	A	9	8	7	6	5	4	3	2	1	0
RYnF to RYn0	Station number 4				Station number 3				Station number 2				Station number 1			
to	to															
RY(n+2)F to RY(n+2)0	Station number 12				Station number 11				Station number 10				Station number 9			
RY(n+3)F to RY(n+3)0	Use prohibited															

(b) The following table lists the I/O signals for 4 occupied station setting

Remote input (RX) of CC-Link	Remote input (X) of CC-Link/LT															
	F	E	D	C	B	A	9	8	7	6	5	4	3	2	1	0
RXnF to RXn0	Station number 4				Station number 3				Station number 2				Station number 1			
to	to															
RX(n+6)F to RX(n+6)0	Station number 28				Station number 27				Station number 26				Station number 25			
RX(n+7)F to RX(n+7)0	Use prohibited															

Remote output (RY) of CC-Link	Remote output (Y) of CC-Link/LT															
	F	E	D	C	B	A	9	8	7	6	5	4	3	2	1	0
RYnF to RYn0	Station number 4				Station number 3				Station number 2				Station number 1			
to	to															
RY(n+6)F to RY(n+6)0	Station number 28				Station number 27				Station number 26				Station number 25			
RY(n+7)F to RY(n+7)0	Use prohibited															

(c) The following table lists the I/O signals for 8 occupied station (4 occupied stations × 2 modules) setting

Remote input (RX) of CC-Link	Remote input (X) of CC-Link/LT															
	F	E	D	C	B	A	9	8	7	6	5	4	3	2	1	0
RXnF to RXn0	Station number 4				Station number 3				Station number 2				Station number 1			
to	to															
RX(n+6)F to RX(n+6)0	Station number 28				Station number 27				Station number 26				Station number 25			
RX(n+7)F to RX(n+7)0	Use prohibited															
RX(n+8)F to RX(n+8)0	Station number 32				Station number 31				Station number 30				Station number 29			
to	to															
RX(n+E)F to RX(n+E)0	Station number 56				Station number 55				Station number 54				Station number 53			
RX(n+F)F to RX(n+F)0	Use prohibited															

Remote output (RY) of CC-Link	Remote output (Y) of CC-Link/LT															
	F	E	D	C	B	A	9	8	7	6	5	4	3	2	1	0
RYnF to RYn0	Station number 4				Station number 3				Station number 2				Station number 1			
to	to															
RY(n+6)F to RY(n+6)0	Station number 28				Station number 27				Station number 26				Station number 25			
RY(n+7)F to RY(n+7)0	Use prohibited															
RY(n+8)F to RY(n+8)0	Station number 32				Station number 31				Station number 30				Station number 29			
to	to															
RY(n+E)F to RY(n+E)0	Station number 56				Station number 55				Station number 54				Station number 53			
RY(n+F)F to RY(n+F)0	Use prohibited															

(2) Remote I/O signal list for 8-point mode setting

(a) The following table lists the I/O signals for 2 occupied station setting

Remote input (RX) of CC-Link	Remote input (X) of CC-Link/LT															
	F	E	D	C	B	A	9	8	7	6	5	4	3	2	1	0
RXnF to RXn0	Station number 2								Station number 1							
to	to															
RX(n+2)F to RX(n+2)0	Station number 6								Station number 5							
RX(n+3)F to RX(n+3)0	Use prohibited															

Remote output (RY) of CC-Link	Remote output (Y) of CC-Link/LT															
	F	E	D	C	B	A	9	8	7	6	5	4	3	2	1	0
RYnF to RYn0	Station number 2								Station number 1							
to	to															
RY(n+2)F to RY(n+2)0	Station number 6								Station number 5							
RY(n+3)F to RY(n+3)0	Use prohibited															

(b) The following table lists the I/O signals for 4 occupied station setting

Remote input (RX) of CC-Link	Remote input (X) of CC-Link/LT															
	F	E	D	C	B	A	9	8	7	6	5	4	3	2	1	0
RXnF to RXn0	Station number 2								Station number 1							
to	to															
RX(n+6)F to RX(n+6)0	Station number 14								Station number 13							
RX(n+7)F to RX(n+7)0	Use prohibited															

Remote output (RY) of CC-Link	Remote output (Y) of CC-Link/LT															
	F	E	D	C	B	A	9	8	7	6	5	4	3	2	1	0
RYnF to RYn0	Station number 2								Station number 1							
to	to															
RY(n+6)F to RY(n+6)0	Station number 14								Station number 13							
RY(n+7)F to RY(n+7)0	Use prohibited															



(c) The following table lists the I/O signals for 8 occupied station (4 occupied stations × 2 modules) setting

Remote input (RX) of CC-Link	Remote input (X) of CC-Link/LT															
	F	E	D	C	B	A	9	8	7	6	5	4	3	2	1	0
RXnF to RXn0	Station number 2								Station number 1							
to	to															
RX(n+6)F to RX(n+6)0	Station number 14								Station number 13							
RX(n+7)F to RX(n+7)0	Use prohibited															
RX(n+8)F to RX(n+8)0	Station number 16								Station number 15							
to	to															
RX(n+E)F to RX(n+E)0	Station number 28								Station number 27							
RX(n+F)F to RX(n+F)0	Use prohibited															

Remote output (RY) of CC-Link	Remote output (Y) of CC-Link/LT															
	F	E	D	C	B	A	9	8	7	6	5	4	3	2	1	0
RYnF to RYn0	Station number 2								Station number 1							
to	to															
RY(n+6)F to RY(n+6)0	Station number 14								Station number 13							
RY(n+7)F to RY(n+7)0	Use prohibited															
RY(n+8)F to RY(n+8)0	Station number 16								Station number 15							
to	to															
RY(n+E)F to RY(n+E)0	Station number 28								Station number 27							
RY(n+F)F to RY(n+F)0	Use prohibited															

(3) Remote I/O signal list for 16-point mode setting

(a) The following table lists the I/O signals for 2 occupied station setting

Remote input (RX) of CC-Link	Remote input (X) of CC-Link/LT															
	F	E	D	C	B	A	9	8	7	6	5	4	3	2	1	0
RXnF to RXn0	Station number 1															
to	to															
RX(n+2)F to RX(n+2)0	Station number 3															
RX(n+3)F to RX(n+3)0	Use prohibited															

Remote output (RY) of CC-Link	Remote output (Y) of CC-Link/LT															
	F	E	D	C	B	A	9	8	7	6	5	4	3	2	1	0
RYnF to RYn0	Station number 1															
to	to															
RY(n+2)F to RY(n+2)0	Station number 3															
RY(n+3)F to RY(n+3)0	Use prohibited															

(b) The following table lists the I/O signals for 4 occupied station setting

Remote input (RX) of CC-Link	Remote input (X) of CC-Link/LT															
	F	E	D	C	B	A	9	8	7	6	5	4	3	2	1	0
RXnF to RXn0	Station number 1															
to	to															
RX(n+6)F to RX(n+6)0	Station number 7															
RX(n+7)F to RX(n+7)0	Use prohibited															

Remote output (RY) of CC-Link	Remote output (Y) of CC-Link/LT															
	F	E	D	C	B	A	9	8	7	6	5	4	3	2	1	0
RYnF to RYn0	Station number 1															
to	to															
RY(n+6)F to RY(n+6)0	Station number 7															
RY(n+7)F to RY(n+7)0	Use prohibited															

(c) The following table lists the I/O signals for 8 occupied station (4 occupied stations × 2 modules) setting

Remote input (RX) of CC-Link	Remote input (X) of CC-Link/LT															
	F	E	D	C	B	A	9	8	7	6	5	4	3	2	1	0
RXnF□RXn0	Station number 1															
to	to															
RX(n□6)F□RX(n□6)0	Station number 7															
RX(n□7)F□RX(n□7)0	Use prohibited															
RX(n□8)F□RX(n□8)0	Station number 8															
to	to															
RX(n□E)F□RX(n□E)0	Station number 14															
RX(n□F)F□RX(n□F)0	Use prohibited															

Remote input (RY) of CC-Link	Remote input (Y) of CC-Link/LT															
	F	E	D	C	B	A	9	8	7	6	5	4	3	2	1	0
RYnF□RYn0	Station number 1															
to	to															
RY(n□6)F□RY(n□6)0	Station number 7															
RY(n□7)F□RY(n□7)0	Use prohibited															
RY(n□8)F□RY(n□8)0	Station number 8															
to	to															
RY(n□E)F□RY(n□E)0	Station number 14															
RY(n□F)F□RY(n□F)0	Use prohibited															

(4) Functions of remote I/O signals

Device No.	Signal Name	Description
RX(n+3)A *1	Error status flag	Turns on when a remote I/O error occurs on CC-Link/LT side or when all stations or remote stations become faulty. Automatically turns off upon recovery from the error.
RX(n+3)B *2	Remote READY	Turns on during normal operation. Turns off in the CC-Link/LT side self-loopback test mode or when a switch error occurs on a CC-Link/LT side.

- \*1: When 4 stations are occupied   RX(n+7)A  
       When 8 stations are occupied   RX(n+7)A, RX(n+F)A
- \*2: When 4 stations are occupied   RX(n+7)B  
       When 8 stations are occupied   RX(n+7)B, RX(n+F)B

### 3.6 Concept of the Number of Control Points (Point Mode Setting for CC-Link/LT and Number of Occupied Stations Setting for CC-Link)

This section explains the concept of the settings required for system configuration, i.e., point mode setting and number of occupied stations setting.

The point mode setting sets the number of points that can be controlled for each occupied remote station in the CC-Link/LT.

The point mode has three different modes: 4-point mode, 8-point mode, and 16-point mode. If the number of occupied stations is the same, the number of remote stations that can be controlled in the CC-Link/LT changes depending on the setting of the point mode. Note that, when connecting a remote device station to the CC-Link/LT system, set the 16-point mode in the point mode setting for the CC-Link/LT.

#### 3.6.1 Setting number of occupied stations

This section explains a simple setting method of the point mode setting and number of occupied stations setting.

As the point mode, use the 4-point mode. According to the number of I/O points of the remote station, refer to the following table and set the number of occupied stations.

Number of Remote Station I/O Points	Number of Occupied Stations Setting of AJ65SBT-CLB	Point Mode Setting of AJ65SBT-CLB
48 points or less	2 stations	4-point mode
49 to 112 points	4 stations	
113 to 224 points	8 stations (4 occupied stations × 2 modules)	

<b>POINT</b>
Since the default setting is the 8-point mode, change it to the 4-point mode.

#### 3.6.2 Setting point mode

This section explains the point mode setting and the application method for number of occupied stations setting.

- (1) If the number of occupied stations is set the same, the number of controllable remote stations changes depending on the point mode setting, as the following table shows.

Number of Occupied Stations Setting		2 Occupied Stations	4 Occupied Stations	8 Occupied Stations (4 occupied stations × 2 modules)
Point mode setting	4-point mode	12 stations	28 stations	56 stations
	8-point mode	6 stations	14 stations	28 stations
	16-point mode	3 stations	7 stations	14 stations

- (2) If the remote module is the same, the number of occupied stations changes due to the point mode.

For example, if a 16-point module is used, the occupied station number changes from 4 occupied stations to 2 occupied stations to 1 occupied station when the point mode changes from the 4-point mode to the 8-point mode to the 16-point mode.

(3) As the point mode, it is recommended to use the 4-point mode that has the least number of empty points.

Example: In the case of one 2-point remote station, five 4-point remote stations, one 8-point remote station and one 16-point remote station

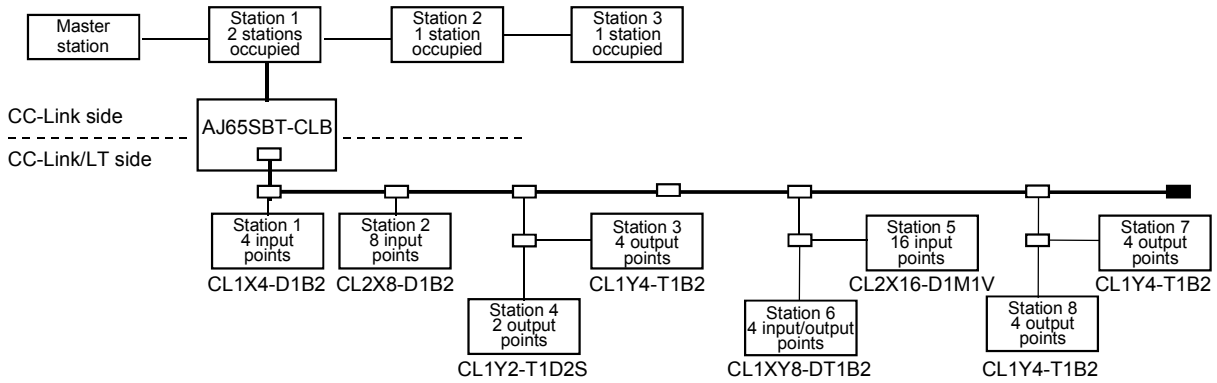

■ 4-point mode  
(4 points/station)  
Number of occupied stations: 2 stations  
(maximum 48 points)  
Total number of stations: 12 stations

■ 8-point mode  
(8 points/station)  
Number of occupied stations: 4 stations  
(maximum 112 points)  
Total number of stations: 9 stations

■ 16-point mode  
(16 points/station)  
Number of occupied stations: 4 stations  
(maximum 112 points)  
Total number of stations: 8 stations

■ 16-point mode (4 points/station)  
Number of occupied stations: 8 stations  
(4 occupied stations × 2 stations)  
(maximum 224 points)  
Total number of stations: 8 stations

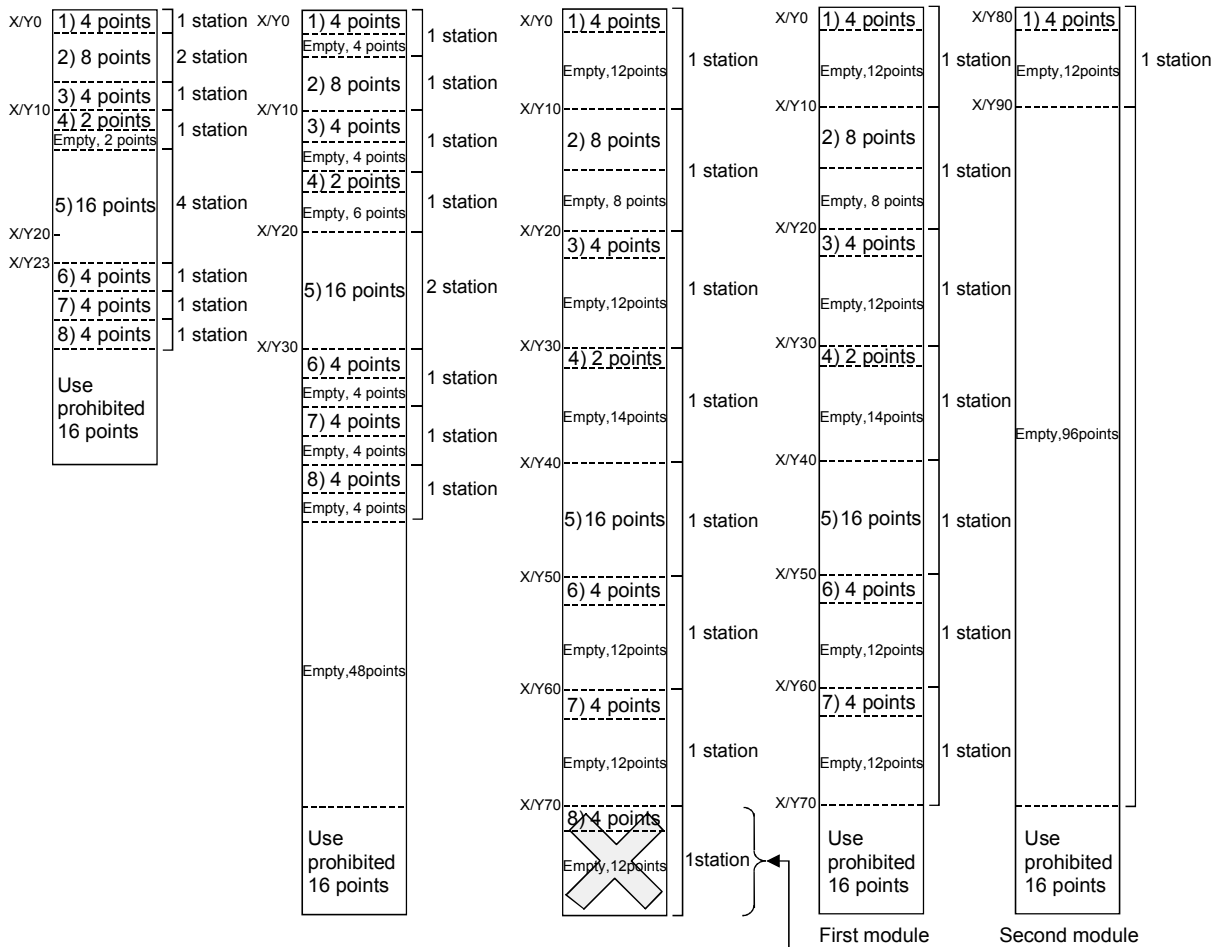

When 4 occupied stations and 16-point mode are selected in the above system, Station 8 cannot be set. (When the 16-point mode has been set for 4 occupied stations, only up to 7 stations can be set.) Set 8 occupied stations (4 occupied stations × 2 modules) as shown above, or change the point mode setting to the 4-point mode or 8-point mode.

- (4) The assignment of the I/O numbers is explained below using the assignment sheet in the Appendices. It is an example where the number of occupied stations is 2 and the point mode setting is the 4-point mode as shown in the configuration of the Section (3).

Station No.	Model Name	Input	Output	Station No.	Model Name	Input	Output
1	CL1X4-D1B2	X 00	Y 00	9	//	X 20	Y 20
		01	01			21	21
		02	02			22	22
		03	03			23	23
2	CL2X8-D1B2 (2 stations occupied)	X 04	Y 04	10	CL1X8-DT1B2	X 24	Y 24
		05	05			25	25
		06	06			26	26
		07	07			27	27
3	//	X 08	Y 08	11	CL1Y4-T1B2	X 28	Y 28
		09	09			29	29
		0A	0A			2A	2A
		0B	0B			2B	2B
4	CL1Y4-T1B2	X 0C	Y 0C	12	CL1Y4-T1B2	X 2C	Y 2C
		0D	0D			2D	2D
		0E	0E			2E	2E
		0F	0F			2F	2F
5	CL1Y2-T1D2S	X 10	Y 10	13	X	X 0	Y 0
		1	1			1	1
		2	2			2	2
		3	3			3	3
6	CL2X16-D1M1V (4 stations occupied)	X 14	Y 14	14	X	X 4	Y 4
		15	15			5	5
		16	16			6	6
		17	17			7	7
7	//	X 18	Y 18	15	X	X 8	Y 8
		19	19			9	9
		1A	1A			A	A
		1B	1B			B	B
8	//	X 1C	Y 1C	16	X	X C	Y C
		1D	1D			D	D
		1E	1E			E	E
		1F	1F			F	F

### 3.7 Remote Registers

The AJ65SBT-CLB has the remote registers to make data communication with the master module.

This section explains the assignment and data structure of the remote registers of the AJ65SBT-CLB.

#### 3.7.1 Assignment of remote registers

The following tables indicate the assignment of the remote registers.

##### (1) RWw

Address	Remote Register Definition	Initial value	Reference
RWwn	Last station number setting	0	Sec. 3.7.2
RWwn+1	Data link stop/restart instructions	0	Sec. 3.7.3
RWwn+2	Error status flag clear	0	Sec. 3.7.4
RWwn+3 to RWwn+F	Use prohibited	—	—

n: Address assigned to the master station in station number setting.

##### (2) RWr

###### (a) When 2 stations are occupied

Address	Remote Register Definition	Reference
RWrm	Data of operating statuses	Sec. 3.7.5
RWrm+1	Data of faulty station : Station number 1 to 12	Sec. 3.7.6
RWrm+2	Remote I/O error data :Station number 1 to 12	Sec. 3.7.7
RWrm+3	Data of remote station connection	Sec. 3.7.8
RWrm+4	Setting data	Sec. 3.7.9
RWrm+5 to RWrm+7	Use prohibited	—

n: Address assigned to the master station in station number setting.

###### (b) When 4 stations are occupied

Address	Remote Register Definition	Reference
RWrm	Data of operating states	Sec. 3.7.5
RWrm+1 RWrm+2	Data of faulty station : Station number 1 to 28	Sec. 3.7.6
RWrm+3 RWrm+4	Remote I/O error data :Station number 1 to 28	Sec. 3.7.7
RWrm+5 RWrm+6	Data of remote station connection	Sec. 3.7.8
RWrm+7	Setting data	Sec. 3.7.9
RWrm+8 to RWrm+F	Use prohibited	—

n: Address assigned to the master station in station number setting.

- (c) When 8 stations (4 occupied stations  $\times$  2 modules) are occupied

First module

Address	Remote Register Definition	Reference
RWr <sub>n</sub>	Data of operating statuses	Sec. 3.7.5
RWr <sub>n+1</sub> RWr <sub>n+2</sub>	Data of faulty station : Station number 1 to 32	Sec. 3.7.6
RWr <sub>n+3</sub> RWr <sub>n+4</sub>	Remote I/O error data : Station number 1 to 32	Sec. 3.7.7
RWr <sub>n+5</sub> RWr <sub>n+6</sub>	Data of remote station connection	Sec. 3.7.8
RWr <sub>n+7</sub>	Setting data	Sec. 3.7.9
RWr <sub>n+8</sub> to RWr <sub>n+F</sub>	Use prohibited	—

Second module

Address	Remote Register Definition	Reference
RWr <sub>(n+1)</sub>	Data of operating states	Sec. 3.7.5
RWr <sub>(n+1) +1</sub> RWr <sub>(n+1) +2</sub>	Data of faulty station : Station number 33 to 56	Sec. 3.7.6
RWr <sub>(n+1) +3</sub> RWr <sub>(n+1) +4</sub>	Remote I/O error data : Station number 33 to 56	Sec. 3.7.7
RWr <sub>(n+1) +5</sub> RWr <sub>(n+1) +6</sub>	Data of remote station connection	Sec. 3.7.8
RWr <sub>(n+1) +7</sub>	Setting data	Sec. 3.7.9
RWr <sub>(n+1) +8</sub> to RWr <sub>(n+1) +F</sub>	Use prohibited	—

n: Address assigned to the master station in station number setting.

#### POINT

The prohibited remote register areas are used by the system and therefore cannot be used by the user.

If data is written to the buffer memory area corresponding to the prohibited remote register area or to the device specified for auto refresh, the functions of the AJ65SBT-CLB cannot be guaranteed.



### 3.7.2 Last station number setting (common to 2, 4 and 8 occupied stations (4 occupied stations × 2 modules): Address RWwn)

The setting status of the last station number is stored.

Bit	Name	Description	Initial value
b0 to b7	Empty	Fixed at 0	—
b8 to b13	Last station number setting	<p>Set the last station number for a data link. This eliminates the processing of data link to the non-connected stations, reducing the link refresh time.</p> <p>If the value is set beyond the number of connectable stations (refer to Section 3.6.2), the setting will be ignored.</p> <p>&lt;Setting range&gt;</p> <p>2 occupied stations: Station 1 to 12            4 occupied stations: Station 1 to 28            8 occupied stations (4 occupied stations × 2 modules): Station 1 to 56</p> <p>If the value of 0 or more than 56 is set, a data link is performed with the number of stations within the setting range.</p>	0
b14, b15	Empty	Fixed at 0	—

### 3.7.3 Data link stop/restart instructions (common to 2, 4 and 8 occupied stations (4 occupied stations × 2 modules): Address RWwn+1)

Data link stop and restart are controlled. When a data link stop and a data link restart are requested simultaneously, the data link stop has higher priority.

Bit	Name	Description	Initial value
b0	Data link stop	0 : Data link stop not requested 1 : Data link stop requested	0
b1 to b14	Empty	Fixed at 0	—
b15	Data link restart	0 : Data link restart not requested 1 : Data link restart requested	0

### 3.7.4 Error status flag clear (common to 2, 4 and 8 occupied stations (4 occupied stations × 2 modules): Address RWwn+2)

Error of station outside control range is cleared.

Bit	Name	Description	Initial value
b0 to b2	Empty	Fixed at 0	—
b3	Error of station outside control range clear	0 : Clear not requested 1 : Clear requested	0
b4 to b15	Empty	Fixed at 0	—

### 3.7.5 Data of operating statuses (common to 2, 4 and 8 occupied stations (4 occupied stations × 2 modules): Address RWrn)

The CC-Link/LT side operating status is stored.

Bit	Name	Description
b0	Data link status	0: Data link stopped 1: Data link being executed
b1	Initial communication status	0: Initial communication not completed 1: Initial communication completed
b2 to b7	Empty	Fixed at 0
b8	Data link failure	0: Data link normal 1: One or more faulty station in data link identified
b9	All stations failed	0: One or more normal data link station identified 1: All stations are faulty
b10	Remote I/O error	0: No remote I/O error 1: One or more faulty remote I/O station
b11	Error of station outside control range	0: No error 1: Remote station(s) set to the station number higher than the last of refresh range
b12	Point mode setting error	0: Normal 1: Point mode switch set outside valid range
b13	Transmission speed setting error	0: Normal 1: Transmission rate setting switch set outside valid range
b14	Switching during operation	0: No switching 1: Switching identified
b15	Hardware failure	0: Normal 1: Failure identified by self-loopback test

3.7.6 Data of faulty station (2 occupied stations: Address RWrn+1, common to 4 and 8 occupied stations (4 occupied stations × 2 modules): Address RWrn+1, RWrn+2)

The data link statuses of the CC-Link/LT remote stations are stored.

- When 2 stations are occupied, the data of faulty stations in the CC-Link/LT is stored into RWrn+1.
- When 4 or 8 stations (4 occupied stations × 2 modules) are occupied, the data of faulty stations in the CC-Link/LT is stored into RWrn+1, RWrn+2.

Number of Occupied Stations		Number of Stations
When 2 stations are occupied		1 to 12 stations
When 4 stations are occupied		1 to 28 stations
When 8 stations (4 occupied stations × 2 modules) are occupied	First module	1 to 32 stations
	Second module	33 to 56 stations

(1) When 2 stations are occupied

Address	b15	b14	b13	b12	b11	b10	b9	b8	b7	b6	b5	b4	b3	b2	b1	b0
RWrn+1	—	—	—	—	Station 12	Station 11	Station 10	Station 9	Station 8	Station 7	Station 6	Station 5	Station 4	Station 3	Station 2	Station 1

0: Normal  
1: Data link error

(2) When 4 stations are occupied

Address	b15	b14	b13	b12	b11	b10	b9	b8	b7	b6	b5	b4	b3	b2	b1	b0
RWrn+1	Station 16	Station 15	Station 14	Station 13	Station 12	Station 11	Station 10	Station 9	Station 8	Station 7	Station 6	Station 5	Station 4	Station 3	Station 2	Station 1
RWrn+2	—	—	—	—	Station 28	Station 27	Station 26	Station 25	Station 24	Station 23	Station 22	Station 21	Station 20	Station 19	Station 18	Station 17

0: Normal  
1: Data link error

(3) When 8 stations (4 occupied stations × 2 modules) are occupied (first module: 1 to 32 stations, second module: 33 to 56 stations)

Address	b15	b14	b13	b12	b11	b10	b9	b8	b7	b6	b5	b4	b3	b2	b1	b0
RWrn+1	Station 16	Station 15	Station 14	Station 13	Station 12	Station 11	Station 10	Station 9	Station 8	Station 7	Station 6	Station 5	Station 4	Station 3	Station 2	Station 1
RWrn+2	Station 32	Station 31	Station 30	Station 29	Station 28	Station 27	Station 26	Station 25	Station 24	Station 23	Station 22	Station 21	Station 20	Station 19	Station 18	Station 17
RWr(n+1)+1	Station 48	Station 47	Station 46	Station 45	Station 44	Station 43	Station 42	Station 41	Station 40	Station 39	Station 38	Station 37	Station 36	Station 35	Station 34	Station 33
RWr(n+2)+2	—	—	—	—	—	—	—	—	Station 56	Station 55	Station 54	Station 53	Station 52	Station 51	Station 50	Station 49

0: Normal  
1: Data link error

3.7.7 Remote I/O error data (2 occupied stations: Address RWrn+2, common to 4 and 8 occupied stations (4 occupied stations × 2 modules): Address RWrn+3, RWrn+4)

The remote I/O error occurrence statuses of the CC-Link/LT remote stations during data link are stored.

For the error definition, refer to the manual of the corresponding CC-Link/LT remote station.

- When 2 stations are occupied, the remote I/O errors of CC-Link/LT are stored into RWrn+2.
- When 4 or 8 stations (4 occupied stations × 2 modules) are occupied, the remote I/O errors of CC-Link/LT are stored into RWrn+3, RWrn+4.

(1) When 2 stations are occupied

Address	b15	b14	b13	b12	b11	b10	b9	b8	b7	b6	b5	b4	b3	b2	b1	b0
RWrn+2	—	—	—	—	Station 12	Station 11	Station 10	Station 9	Station 8	Station 7	Station 6	Station 5	Station 4	Station 3	Station 2	Station 1

- 0: No remote I/O error occurred
- 1: Remote I/O error occurred

(2) When 4 stations are occupied

Address	b15	b14	b13	b12	b11	b10	b9	b8	b7	b6	b5	b4	b3	b2	b1	b0
RWrn+3	Station 16	Station 15	Station 14	Station 13	Station 12	Station 11	Station 10	Station 9	Station 8	Station 7	Station 6	Station 5	Station 4	Station 3	Station 2	Station 1
RWrn+4	—	—	—	—	Station 28	Station 27	Station 26	Station 25	Station 24	Station 23	Station 22	Station 21	Station 20	Station 19	Station 18	Station 17

- 0: No remote I/O error occurred
- 1: Remote I/O error occurred

(3) When 8 stations (4 occupied stations × 2 modules) are occupied (first module: 1 to 32 stations, second module: 33 to 56 stations)

Address	b15	b14	b13	b12	b11	b10	b9	b8	b7	b6	b5	b4	b3	b2	b1	b0
RWrn+3	Station 16	Station 15	Station 14	Station 13	Station 12	Station 11	Station 10	Station 9	Station 8	Station 7	Station 6	Station 5	Station 4	Station 3	Station 2	Station 1
RWrn+4	Station 32	Station 31	Station 30	Station 29	Station 28	Station 27	Station 26	Station 25	Station 24	Station 23	Station 22	Station 21	Station 20	Station 19	Station 18	Station 17
RWr(n+1)+3	Station 48	Station 47	Station 46	Station 45	Station 44	Station 43	Station 42	Station 41	Station 40	Station 39	Station 38	Station 37	Station 36	Station 35	Station 34	Station 33
RWr(n+1)+4	—	—	—	—	—	—	—	—	Station 56	Station 55	Station 54	Station 53	Station 52	Station 51	Station 50	Station 49

- 0: No remote I/O error occurred
- 1: Remote I/O error occurred

3.7.8 Data of remote station connection (2 occupied stations: Address RWrn+3, common to 4 and 8 occupied stations (4 occupied stations × 2 modules): Address RWrn+5, RWrn+6)

The CC-Link/LT remote stations connected on the line are detected, and the connection statuses of the remote stations are stored.

Note that if any remote station is disconnected from the system, the corresponding bit does not turn off (turn to 0) after the connections of the CC-Link/LT remote stations have been detected.

- When 2 stations are occupied, the data of remote station connection of CC-Link/LT is stored into RWrn+3.
- When 4 or 8 stations (4 occupied stations × 2 modules) are occupied, the data of remote station connection of CC-Link/LT is stored into RWrn+5, RWrn+6.

(1) When 2 stations are occupied

Address	b15	b14	b13	b12	b11	b10	b9	b8	b7	b6	b5	b4	b3	b2	b1	b0
RWrn+3	—	—	—	—	Station 12	Station 11	Station 10	Station 9	Station 8	Station 7	Station 6	Station 5	Station 4	Station 3	Station 2	Station 1

0: Remote station not connected

1: Remote station connected

(2) When 4 stations are occupied

Address	b15	b14	b13	b12	b11	b10	b9	b8	b7	b6	b5	b4	b3	b2	b1	b0
RWrn+5	Station 16	Station 15	Station 14	Station 13	Station 12	Station 11	Station 10	Station 9	Station 8	Station 7	Station 6	Station 5	Station 4	Station 3	Station 2	Station 1
RWrn+6	—	—	—	—	Station 28	Station 27	Station 26	Station 25	Station 24	Station 23	Station 22	Station 21	Station 20	Station 19	Station 18	Station 17

0: Remote station not connected

1: Remote station connected

(3) When 8 stations (4 occupied stations × 2 modules) are occupied (first module: 1 to 32 stations, second module: 33 to 56 stations)

Address	b15	b14	b13	b12	b11	b10	b9	b8	b7	b6	b5	b4	b3	b2	b1	b0
RWrn+5	Station 16	Station 15	Station 14	Station 13	Station 12	Station 11	Station 10	Station 9	Station 8	Station 7	Station 6	Station 5	Station 4	Station 3	Station 2	Station 1
RWrn+6	Station 32	Station 31	Station 30	Station 29	Station 28	Station 27	Station 26	Station 25	Station 24	Station 23	Station 22	Station 21	Station 20	Station 19	Station 18	Station 17
RWr(n+1)+5	Station 48	Station 47	Station 46	Station 45	Station 44	Station 43	Station 42	Station 41	Station 40	Station 39	Station 38	Station 37	Station 36	Station 35	Station 34	Station 33
RWr(n+1)+6	—	—	—	—	—	—	—	—	Station 56	Station 55	Station 54	Station 53	Station 52	Station 51	Station 50	Station 49

0: Remote station not connected

1: Remote station connected

### 3.7.9 Setting data (2 occupied stations: Address RW<sub>n</sub>+4, common to 4 and 8 occupied stations (4 occupied stations × 2 modules): Address RW<sub>n</sub>+7)

The setting statuses of the switches for occupied station number setting, transmission speed setting, point mode setting, test mode and data link last station number are stored.

- When 2 stations are occupied, the setting data of CC-Link/LT are stored into RW<sub>n</sub>+4.
- When 4 or 8 stations (4 occupied stations × 2 modules) are occupied, the setting data of CC-Link/LT are stored into RW<sub>n</sub>+7.

Bit	Name	Description
b0 to b1	Number of occupied stations	Setting statuses of the CC-Link side switches SW1, SW2 for operation setting 00: 2 occupied stations    01: 4 occupied stations, 10: 8 occupied stations (4 occupied stations × 2 modules) 11: Setting prohibited
b2 to b3	Transmission speed setting	Setting statuses of the CC-Link side switches SW8, SW9, SW10 for operation setting 00: 156kbps                    01: 625kbps 10: 2.5Mbps                    11: Setting prohibited
b4 to b5	Point mode setting	Setting statuses of the CC-Link side switches SW4, SW5 for operation setting 00: 8-point mode            01: 4-point mode, 10: 16-point mode            11: Setting prohibited
b6	Test mode	Setting status of the CC-Link side switch SW3 for operation setting 0: Under usual conditions 1: At self-loopback test execution time
b7	Not used	—
b8 to b13	Data link last station number	The last station number of the remote station that can perform a data link is stored.
b14 to b15	Not used	—

0: Switch OFF

1: Switch ON

POINT
<ul style="list-style-type: none"> <li>• The values of this remote register change depending on the occupied station number setting, point mode setting and last station number setting.</li> <li>• If any CC-Link/LT remote station connected has a station number setting greater than the value of the data link last station number, an error of station outside control range occurs.</li> </ul>

3.8 Data Link Processing Time

The CC-Link side data link and CC-Link/LT side data link operate asynchronously.

3.8.1 CC-Link link scan time

Refer to the user's manual of the master module.

3.8.2 CC-Link/LT link scan time

This section explains the CC-Link/LT link scan time.

[Link scan time (LS)]

$$LS = a + (b \times N) \times c \text{ [\mu s]}$$

a: Constant

b: Constant

c: Constant

N: Last station number

Transmission speed		2.5 Mbps	625 kbps	156 kbps
a		22	88	353
b	4-point mode	46	41	37
	8-point mode	56	51	47
	16-point mode	76	71	67
c		0.4	1.6	6.4

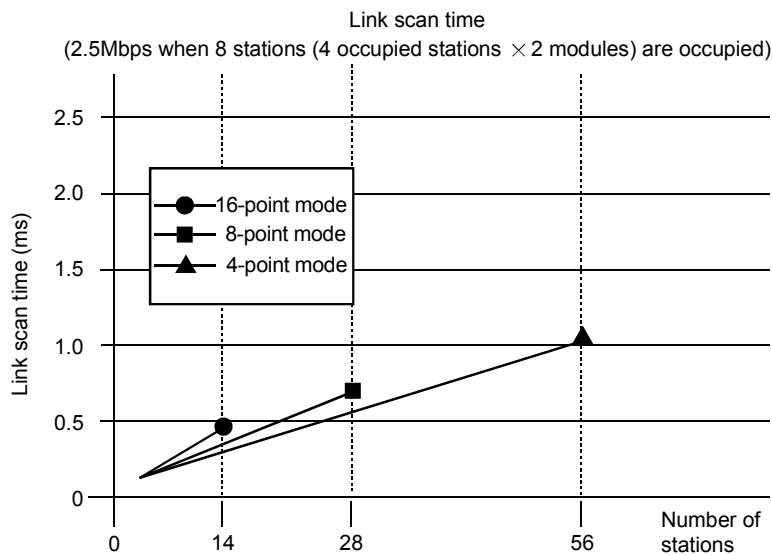

### 3.9 Transmission Delay Time

Transmission delay time is indicated below.

- For input  
Indicates the time from when a signal is input to the remote station until the device (X) of the CPU turns on (off).
- For output  
Indicates the time from when the device (Y) of the CPU turns on (on) until the output of the remote station turns on (off).

The transmission delay time can be calculated by the following expression.

Transmission delay time = "CC-Link side transmission delay time" + "CC-Link/LT side transmission delay time"

#### (1) CC-Link side transmission delay time

This is the time taken until a signal is transmitted between the master station and remote I/O station, which is indicated in the user's manual of the master module. Note that the response time of the remote I/O station should be ignored.

#### (2) CC-Link/LT side transmission delay time

##### (a) AJ65SBT-CLB ← remote station (input)

[Calculation expression]

LS + remote station input response time [ms]

LS : Link scan time (refer to Section 3.8)

##### (b) AJ65SBT-CLB → remote station (output)

[Calculation expression]

LS × 2 + remote station input response time [ms]

LS : Link scan time (refer to Section 3.8)

(Example) When the CC-Link master station sequence program scan time is 10ms, the CC-Link link scan time is 2.5ms, the CC-Link/LT remote I/O station input response time is 1.5ms, the CC-Link/LT transmission speed is 2.5Mbps, the number of stations is 28, and the point mode setting is the 4-point mode

##### 1) For input

CC-Link side :  $10 + 2.5 \times 2 = 15$  [ms]

CC-Link/LT side :  $22 + (46 \times 28) \times 0.4 = 0.54$  [ms]

$15 + 0.54 = 15.54$  [ms]

##### 2) For output

CC-Link side :  $10 + 2.5 \times 3 = 17.5$  [ms]

CC-Link/LT side :  $(22 + (46 \times 28) \times 0.4) \times 2 = 1.08$  [ms]

$17.5 + 1.08 = 18.58$  [ms]





4 PROCEDURE UP TO DATA LINK

This chapter provides the procedure from AJ65SBT-CLB mounting to data link start.

4.1 Procedure Up to Data Link

The following flowchart indicates the procedure to start the data link of the system using the AJ65SBT-CLB.

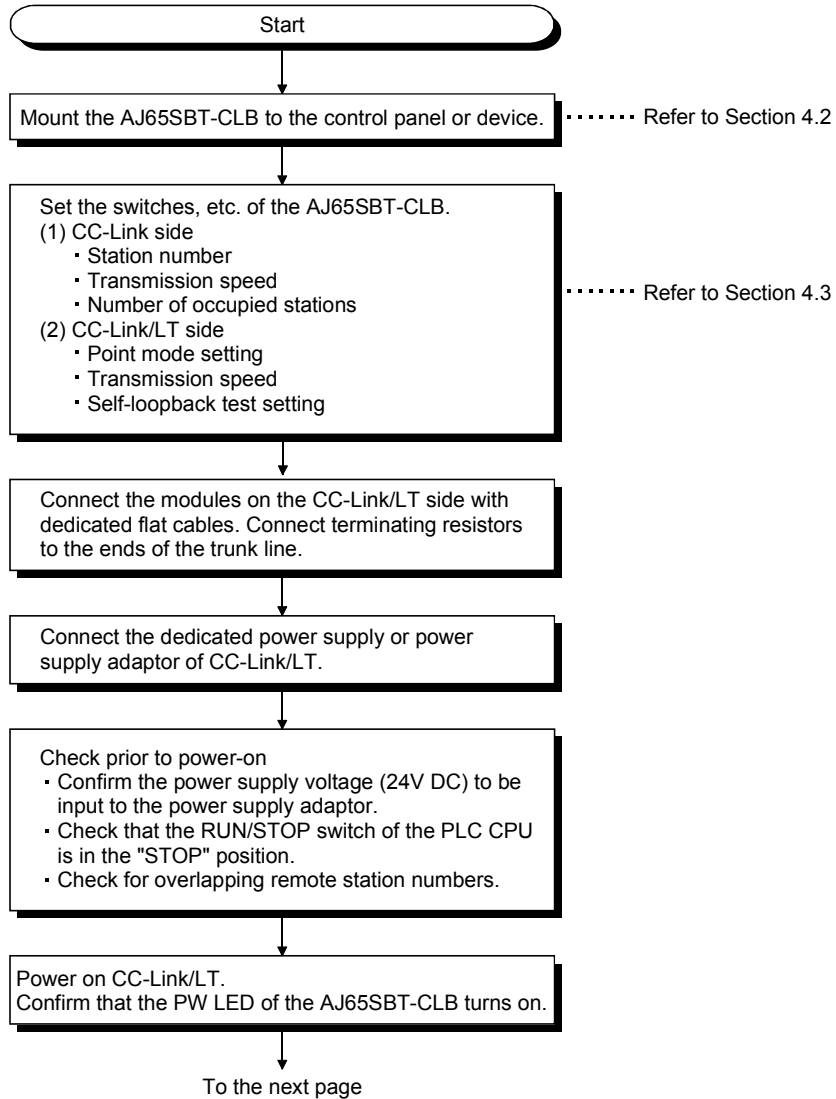

4

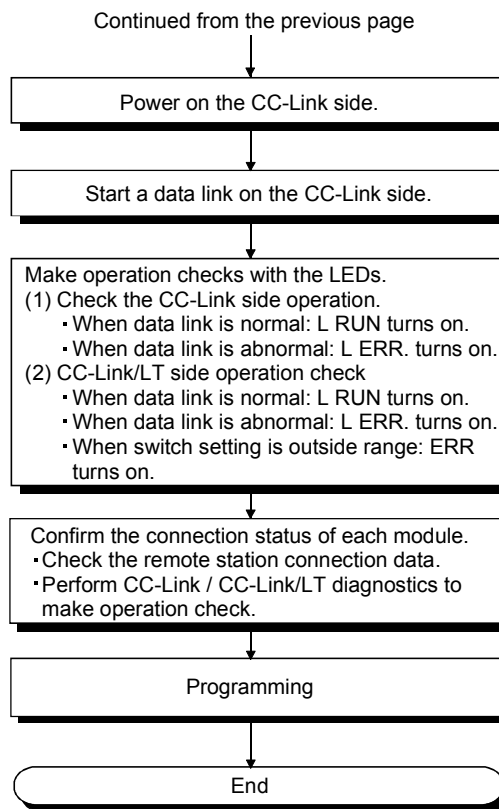
**POINT**

- (1) If the station number of a CC-Link/LT remote station is duplicated, the station may malfunction (false input/output).
- (2) Depending on the combination of the point mode setting and the number of I/O points for the CC-Link/LT remote station used, multiple station numbers may be assigned.  
Carefully check if the station number of the remote station of 8 or more I/O points is not duplicated with the number of the next station.
- (3) When any of the operation setting switches of the AJ65SBT-CLB or the CC-Link/LT remote station has been changed with the system power ON, be sure to turn OFF and then ON the power of the entire CC-Link/LT system.

4.2 Mounting and Installation

4.2.1 Handling precautions

This section explains the precautions for handling the AJ65SBT-CLB.

 <p><b>CAUTION</b></p>	<ul style="list-style-type: none"> <li>▪ Do not touch the terminals while the module is energized. Doing so may cause malfunctions.</li> <li>▪ Be careful not to let foreign matter such as dust or wire chips get inside the module. This may cause a fire, failure or malfunctions.</li> <li>▪ Do not disassemble or modify the module. Doing so may cause a failure, malfunction, injury or fire.</li> <li>▪ Do not touch the conductive and electronic parts of the module directly. Doing so may cause a malfunction or failure of the module.</li> <li>▪ Since the case of the module is made of resin, do not drop it or give it a shock. Doing so may damage the module.</li> <li>▪ Tighten the terminal screws within the specified torque range. Loose tightening may cause a short circuit or malfunction. Overtightening may cause a short circuit or malfunction due to damage to the screws or module.</li> <li>▪ When disposing of this product, handle it as industrial waste.</li> <li>▪ Use the module in the environment specified in this manual. Failure to do so may cause an electric shock, fire, malfunction, or damage to or deterioration of the product.</li> <li>▪ Securely fix the module with DIN rails or mounting screws, and securely tighten it within the specified torque range of the mounting screws. Loose tightening may cause a drop or malfunction. Overtightening may cause a drop or malfunction due to damage to the screws or module.</li> <li>▪ Be sure to shut off all phases of the external power supply used by the system before mounting or dismounting the product to or from the panel. Failure to do so may cause a failure or malfunctions of the module.</li> <li>▪ Before handling the module, always touch grounded metal, etc. to discharge static electricity from the human body. Failure to do so can cause the module to fail or malfunction.</li> </ul>
---	--

(1) Tighten the module mounting screws within the following ranges.

Screw Location	Tightening Torque Range
Module mounting screw (M4 screw)	78 to 108N · cm
FG terminal block terminal screw (M3 screw)	42 to 58N · cm

(2) A protective film is attached on the module's surface for the purpose of scratch prevention during transportation. Prior to use, be sure to remove it.

(3) Mount a DIN rail while paying full attention to the following points.

(a) Applicable DIN rail model name (compliant to IEC 60715)

TH35-7.5Fe

TH35-7.5A1

(b) DIN rail mounting screw interval

The pitch of 200mm or less should be ensured for screwing.

(4) When mounting the AJ65SBT-CLB to a DIN rail, push the centerline of the DIN rail hook at the module bottom with your finger until it clicks.

4.3 Part Names and Settings

This section explains the part names, LED displays, and setting methods of switch, etc for the AJ65SBT-CLB.

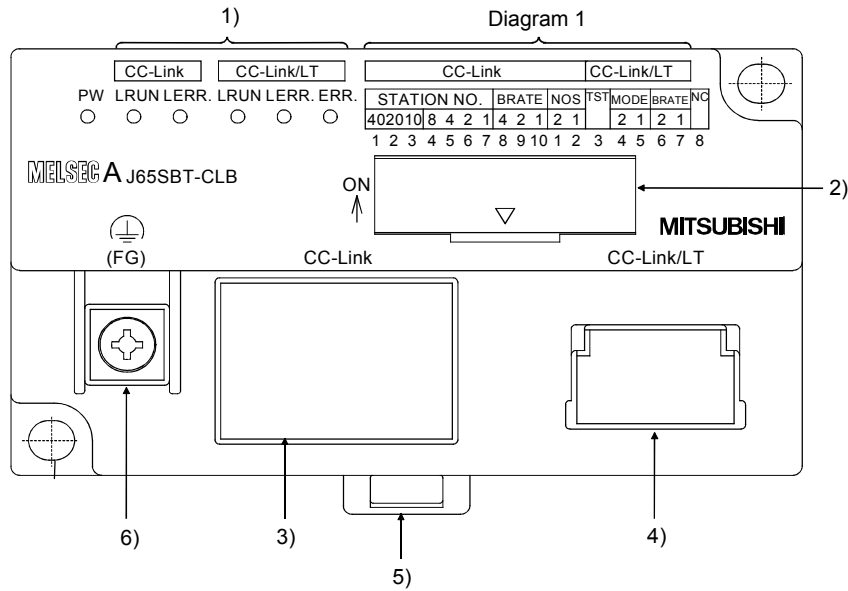

Number	Name	Description		
1)	LED display	Shows the module status as the LED on/off.		
		LED name	Description	
			CC-Link side	CC-Link/LT side
		PW	On: Module normal Off: Module fault or not supplied with power	
	L RUN	On: Data link communication normal Off: Data link communication off (time-out)	<During normal operation> On: Data link being executed Off: Data link stopped <In self-loopback test mode> On: Self-loopback test completed. Off: Self-loopback test failed	

Number	Name	Description	
1)	LED display	Shows the module status as the LED on/off.	
		LED name	Description
		L ERR.	On: CC-Link side switch setting error Data link communication fault error Flicker: CC-Link side switch setting is changed during operation. Off: No error <During normal operation> On: Data link error station (detected) Station outside control range detected Flicker: Data link error stations (all stations) Off: No error <In self-loopback test mode> On: Self-loopback test failed Off: Self-loopback test completed
ERR.	— Setting error detection On: CC-Link/LT side switch setting error Flicker: CC-Link/LT side switch setting is changed during operation. Off: No error		

Diagram 1

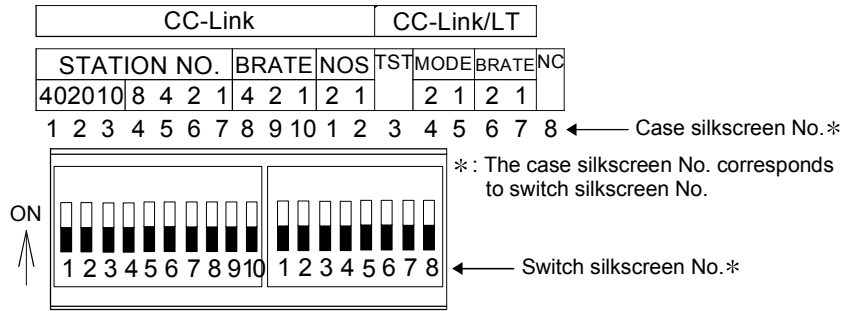

Number	Name	Description																		
2)	Self-loopback test setting switch (CC-Link/LT side) TST	OFF: Normal operation mode (factory-set) ON: Self-loopback test mode																		
	Point mode setting switches (CC-Link/LT side) MODE	<table border="1"> <thead> <tr> <th rowspan="2">Setting Value</th> <th colspan="2">Setting Switches</th> <th rowspan="2">Points</th> </tr> <tr> <th>2</th> <th>1</th> </tr> </thead> <tbody> <tr> <td>0 (factory-set)</td> <td>OFF</td> <td>OFF</td> <td>8 points</td> </tr> <tr> <td>1</td> <td>OFF</td> <td>ON</td> <td>4 points</td> </tr> <tr> <td>2</td> <td>ON</td> <td>OFF</td> <td>16 points</td> </tr> </tbody> </table> <p>Setting a value other than the above will result in a setting error. (The "L ERR." LED on the CC-Link/LT side is lit.)</p>	Setting Value	Setting Switches		Points	2	1	0 (factory-set)	OFF	OFF	8 points	1	OFF	ON	4 points	2	ON	OFF	16 points
	Setting Value	Setting Switches		Points																
2		1																		
0 (factory-set)	OFF	OFF	8 points																	
1	OFF	ON	4 points																	
2	ON	OFF	16 points																	
Transmission speed setting switches (CC-Link/LT side) B RATE	<table border="1"> <thead> <tr> <th rowspan="2">Setting Value</th> <th colspan="2">Setting Switches</th> <th rowspan="2">Transmission Speed</th> </tr> <tr> <th>2</th> <th>1</th> </tr> </thead> <tbody> <tr> <td>0 (factory-set)</td> <td>OFF</td> <td>OFF</td> <td>156 kbps</td> </tr> <tr> <td>1</td> <td>OFF</td> <td>ON</td> <td>625 kbps</td> </tr> <tr> <td>2</td> <td>ON</td> <td>OFF</td> <td>2.5 Mbps</td> </tr> </tbody> </table> <p>Setting a value other than the above will result in a setting error. (The "L ERR." LED on the CC-Link/LT side is lit.)</p>	Setting Value	Setting Switches		Transmission Speed	2	1	0 (factory-set)	OFF	OFF	156 kbps	1	OFF	ON	625 kbps	2	ON	OFF	2.5 Mbps	
Setting Value	Setting Switches		Transmission Speed																	
	2	1																		
0 (factory-set)	OFF	OFF	156 kbps																	
1	OFF	ON	625 kbps																	
2	ON	OFF	2.5 Mbps																	
3)	One-touch connector for communication	A one-touch connector for communication line connection. Connect two optional one-touch connector plugs for communication to the two connector.																		
4)	CC-Link/LT Interface connector	Connector for CC-Link/LT communication line connection.																		
5)	DIN rail hook	Used to mount the module to the DIN rail.																		
6)	FG terminal	Ground terminal																		

#### 4.4 Facing Direction of the Module Installation

The AJ65SBT-CLB can be mounted in any of six orientations with a DIN rail or module mounting screws. (There are no restrictions on the mounting orientations.)

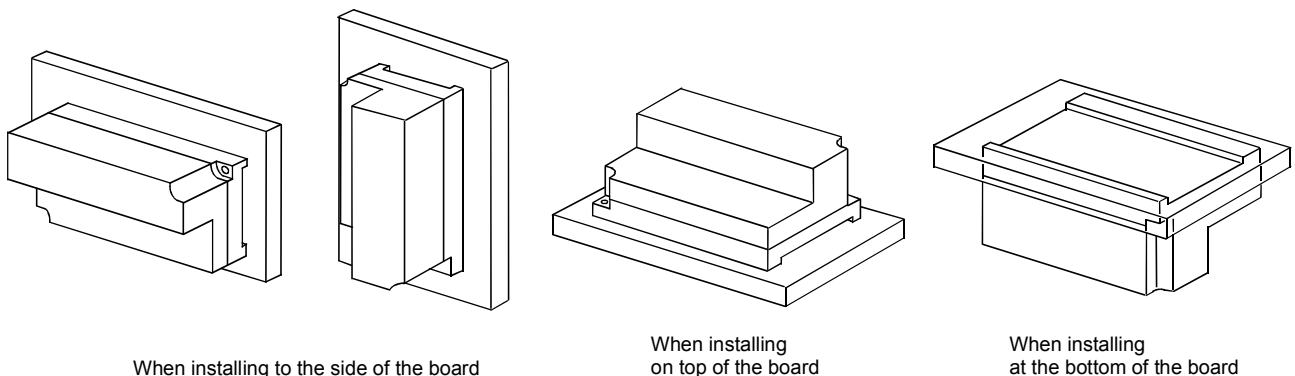



4.5 Connecting Modules by CC-Link/LT Side Cables

This section explains the connection method using the cables designed for CC-Link/LT:

- (1) The cables can be connected regardless of the order of the station number.
- (2) Be sure to set the QJ61CL12 at the end of the trunk line. The terminating resistor close to the QJ61CL12 should be connected within 20 cm from the QJ61CL12.
- (3) Connect terminating resistors to the both ends of the trunk line of CC-Link/LT.

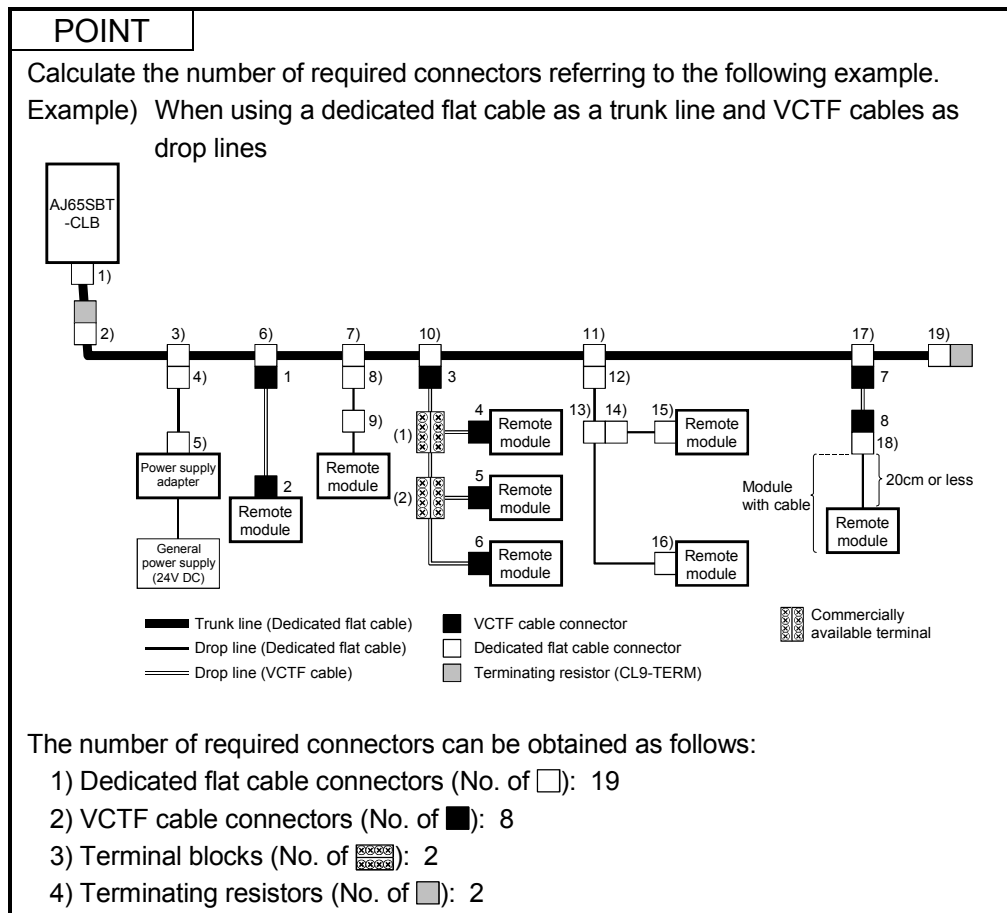

### 4.5.1 How to connect dedicated flat cable connector

This section explains the connection method of the connector for the dedicated flat cable.

#### (1) Components

The components are as follows:

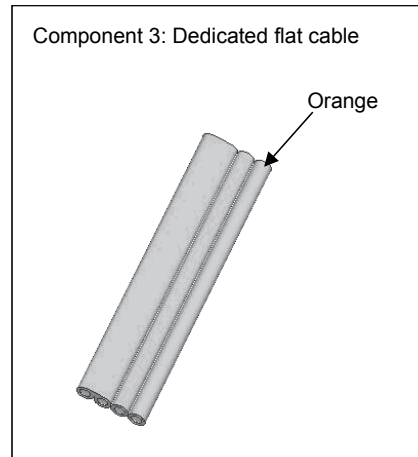
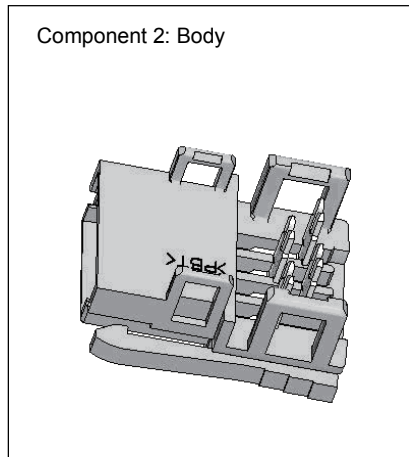
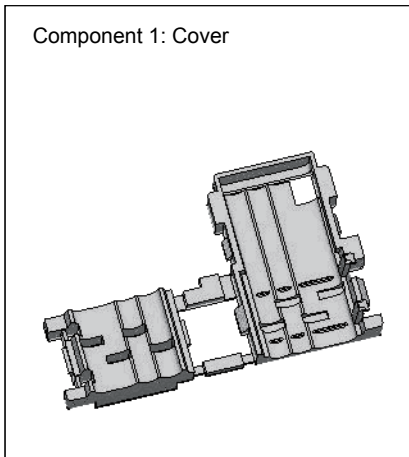

(2) Operating procedure

The operating procedure is illustrated below.

(a) Terminal Processing

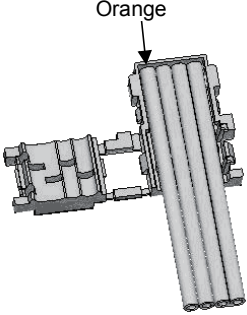
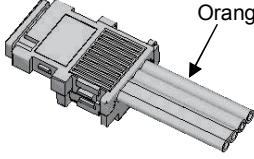
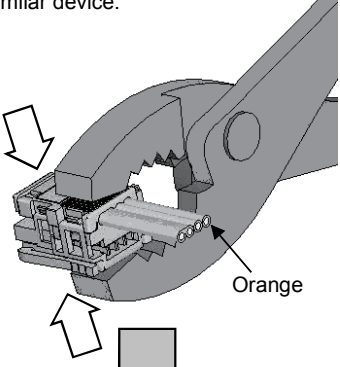
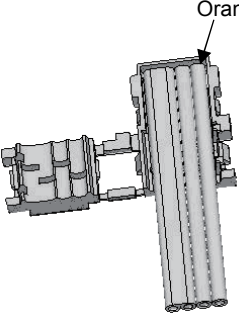
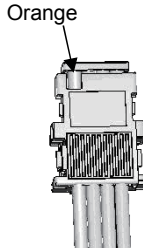
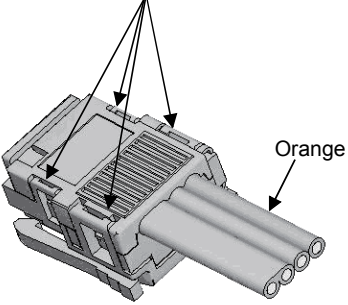
<p>1) Correctly place the dedicated flat cable in the cover. (Check that the position of the orange part is correct.)</p> 	<p>2) Close the cover so that the flat cable will be held between both sides of the cover.</p> 	<p>3) Assemble the cover with the body and pressure-weld them using pliers or similar device.</p> 
<p>Note 1) This setting position is wrong.</p> 	<p>Note 2) If the orange part is seen through the guide hole in the front cover, the wiring is not correct. Open the cover and perform the previous step again.</p> 	<p>4) Check that all of four latches are engaged. Pressure-welding is completed.</p> 

(b) T-Branch Processing

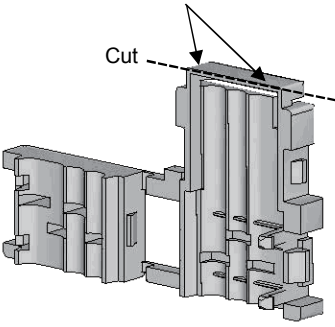
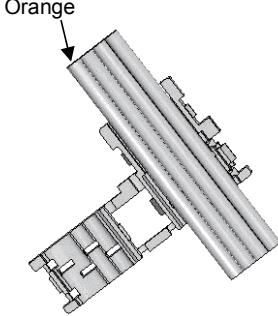
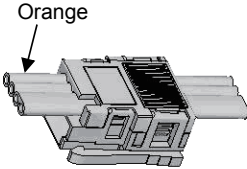
<p>5) Cut 2 portions of the edge of the cover with nippers and remove the edge.</p> 	<p>6) Set the cover at the point where T-branch is to be set.</p> 	<p>7) Execute pressure-welding as instructed in step 3 to 4.</p> 
---	---	--

4.5.2 How to connect VCTF or high flexible cable connector

This section describes how to connect the VCTF cable connector or high flexible cable connector.

(1) Components

The components are shown below.

**Component 1: Cover**  
 For VCTF cable connection: Green  
 For high flexible cable connection: Yellow green

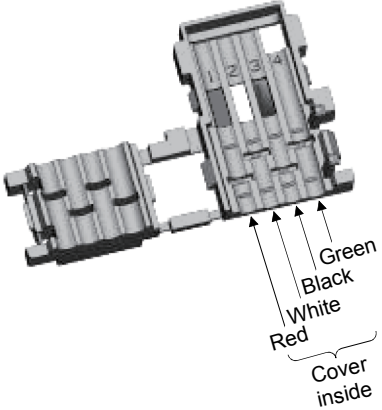

**Component 2: Body (Aqua)**

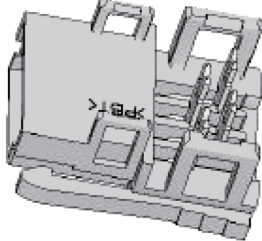

**Component 3: VCTF cable/High flexible cable**

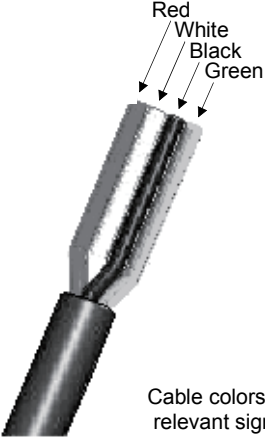

Cable colors and relevant signals

Signal name	Cable color
+24V	Red
DA	White
DB	Black
24G	Green

(2) Operating steps

The operating steps are shown below.

(a) Processing Cable End

1) Place each wire of the VCTF cable or high flexible cable so that its wire color matches the color inside the cover.

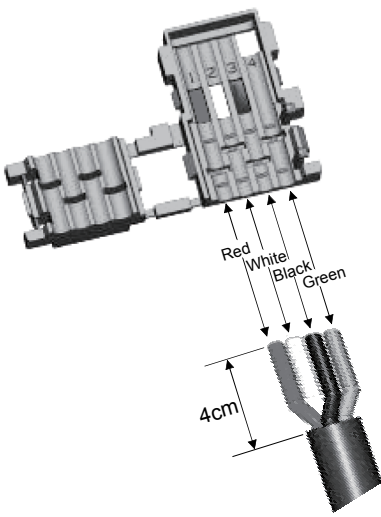

2) Close the cover so that the wires are properly fitted. When the wiring is correct, the green cable can be viewed through the hole. If a red, white or black cable is viewed through the hole, open the cover and correct the wiring. Incorrect wiring may cause failure of the module.

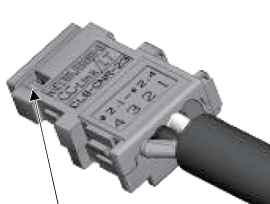

Green: Correct wiring  
Red, white or black: Incorrect wiring

3) Assemble the cover with the body and press-fit them with pliers.

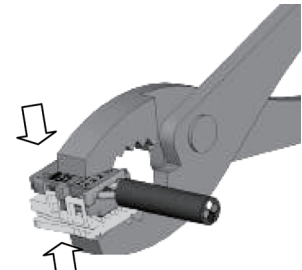

4) Verify that 4 latches are engaged. Press-fitting is complete.

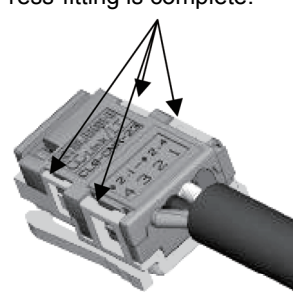

(b) T-Branch Processing (VCTF cable/High flexible cable)

5)-1 When using a terminal block for T-branching  
When connecting VCTF cables or high flexible cables to the terminal block, cable colors must be matched for each terminal.

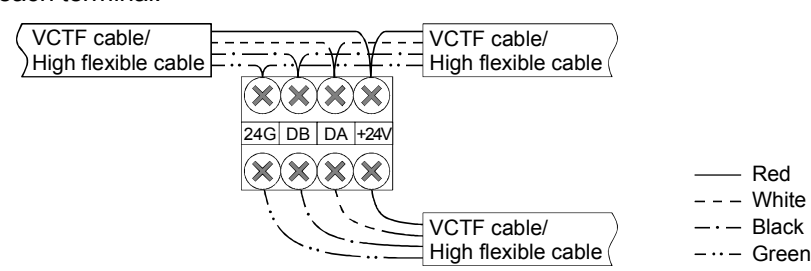

Note) When connecting a dedicated flat cable to the terminal block (e.g. in a case where a VCTF cable is used for the trunk line and dedicated flat cables for drop lines), each of "+24V", "DA", "DB" and "24G" printed on the dedicated flat cable must match the color of the VCTF or high flexible cable as shown in the right table.  
Split the dedicated flat cable into discrete "+24V", "DA", "DB" and "24G" cables.

Dedicated flat cable	VCTF cable/High flexible cable
+24V	Red
DA	White
DB	Black
24G	Green

5)-2 When using a connector for T-branching

After removing the sheath 7cm or more, make a T-branch wiring with a connector in the same way as the T-branch method for the dedicated flat cable.

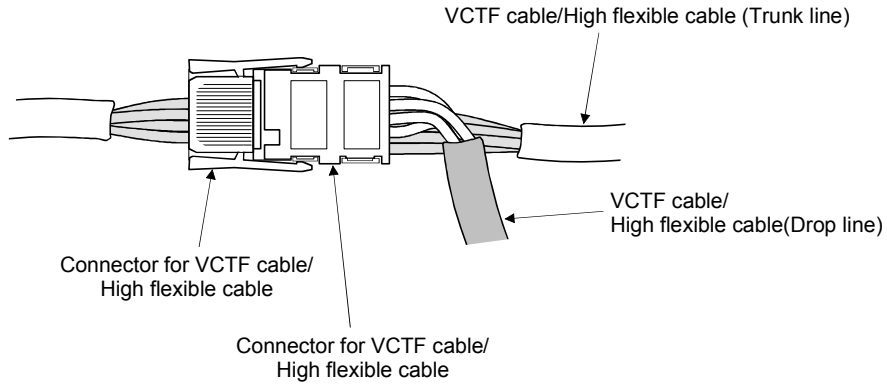

(c) T-Branching procedure (Trunk line: Dedicated flat cable, Drop line: VCTF cable/High flexible cable)

6) Make a T-branch wiring with the connector in the same way as the T-branch method for the dedicated flat cable.

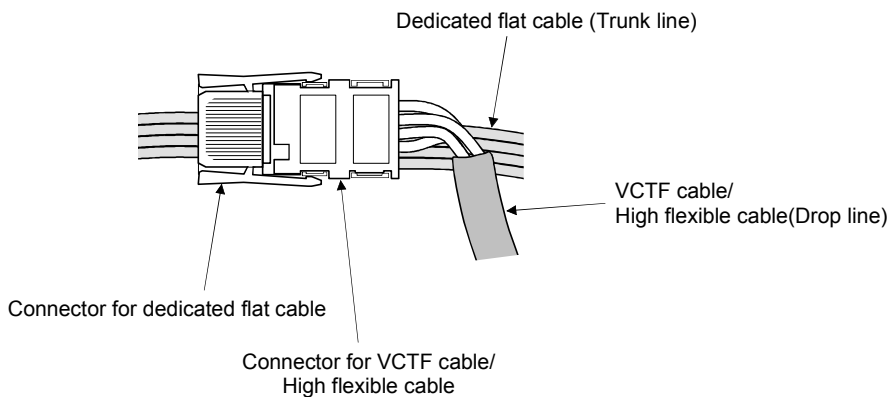

(d) Processing procedure for VCTF cable/High flexible cable connector (Connecting terminating resistor)

7) Cut off the 2 portions of the covers edge with nippers and remove the edge.

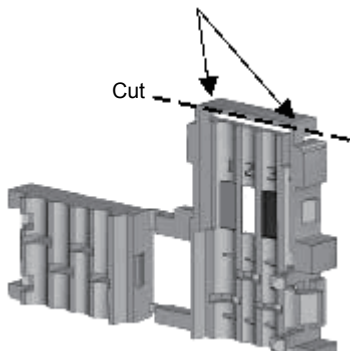

8) Place the cover at the point where the terminating resistor is to be connected.

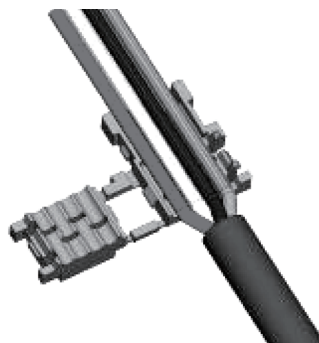

9) Follow the step (a) 3) and 4) and execute press-fitting.

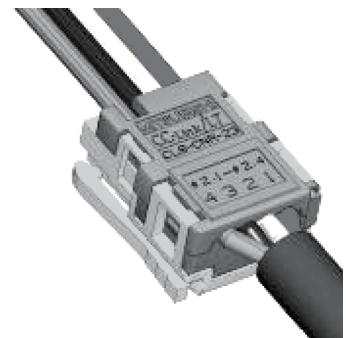

(3) Precautions for use of high flexible cables

Wire the high flexible cable in a way to prevent from applying load to the high flexible cable connection even when the cable moves.

4.5.3 Mixture of different kinds of cables

This section describes mixture of different kinds of cables.

(1) Trunk line

Mixture of different kinds of cables is not allowed.

(2) Drop line

(a) Mixture of different kinds of cables is allowed.

(b) Using more than one kind of cables for the same drop line is not allowed.

(See Fig. 4.1.)

When using a module with cable (e.g. CL1Y2-T1D2S), however, dissimilar cables can be connected if the dedicated flat cable of the module is 20cm long or less. (See Fig. 4.2.)

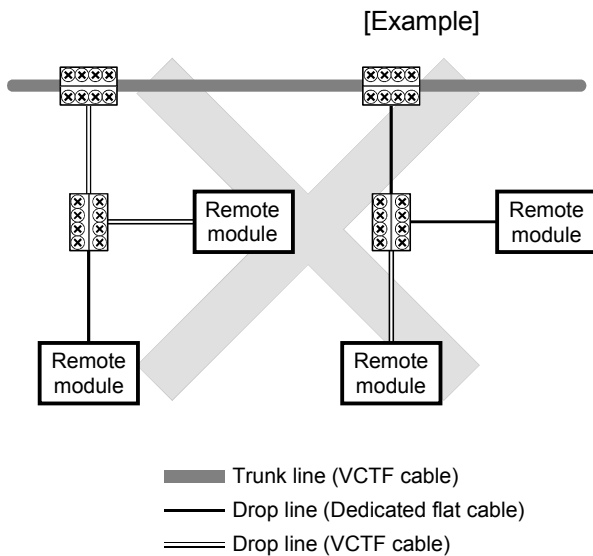

Fig. 4.1

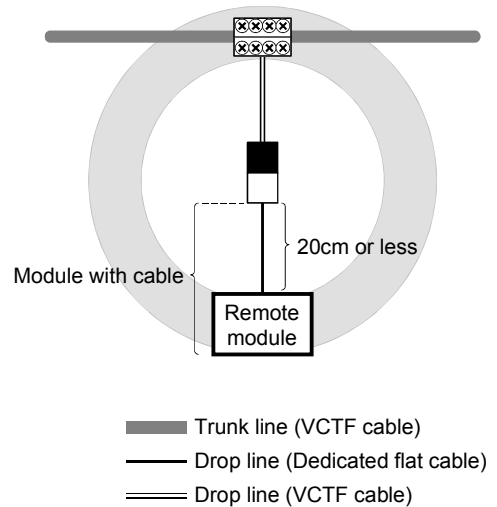
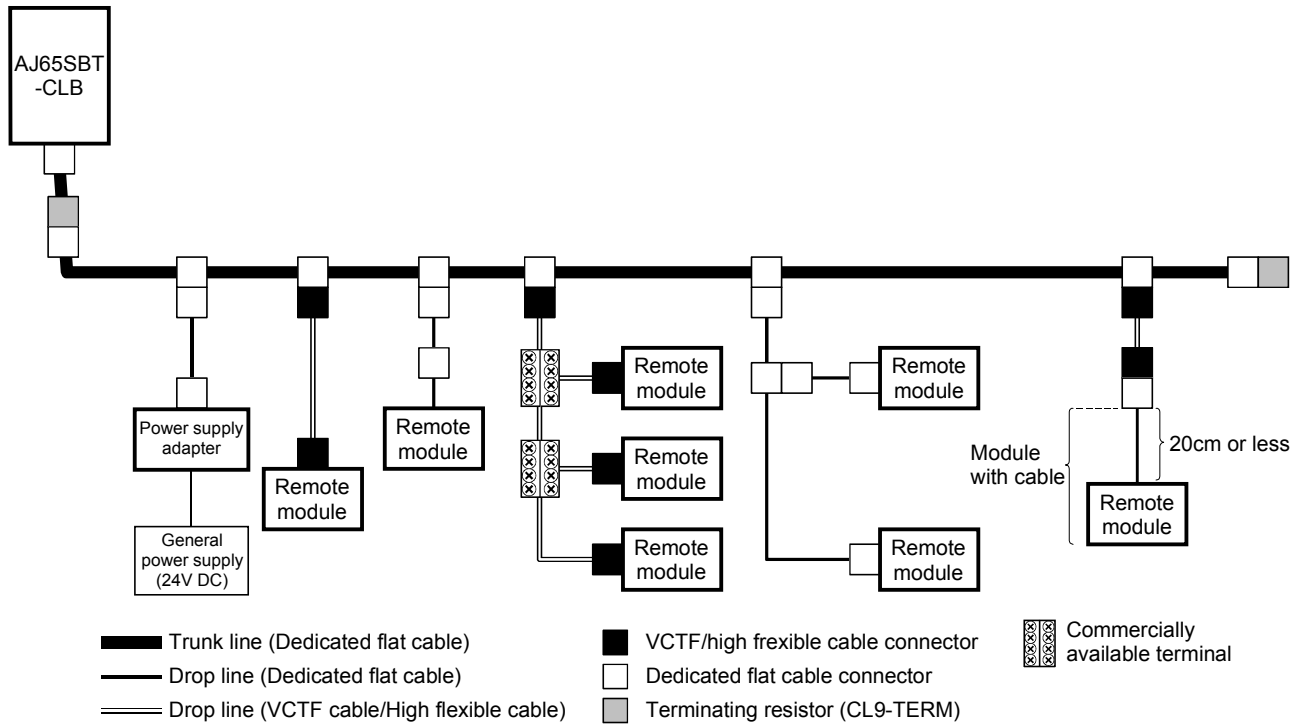
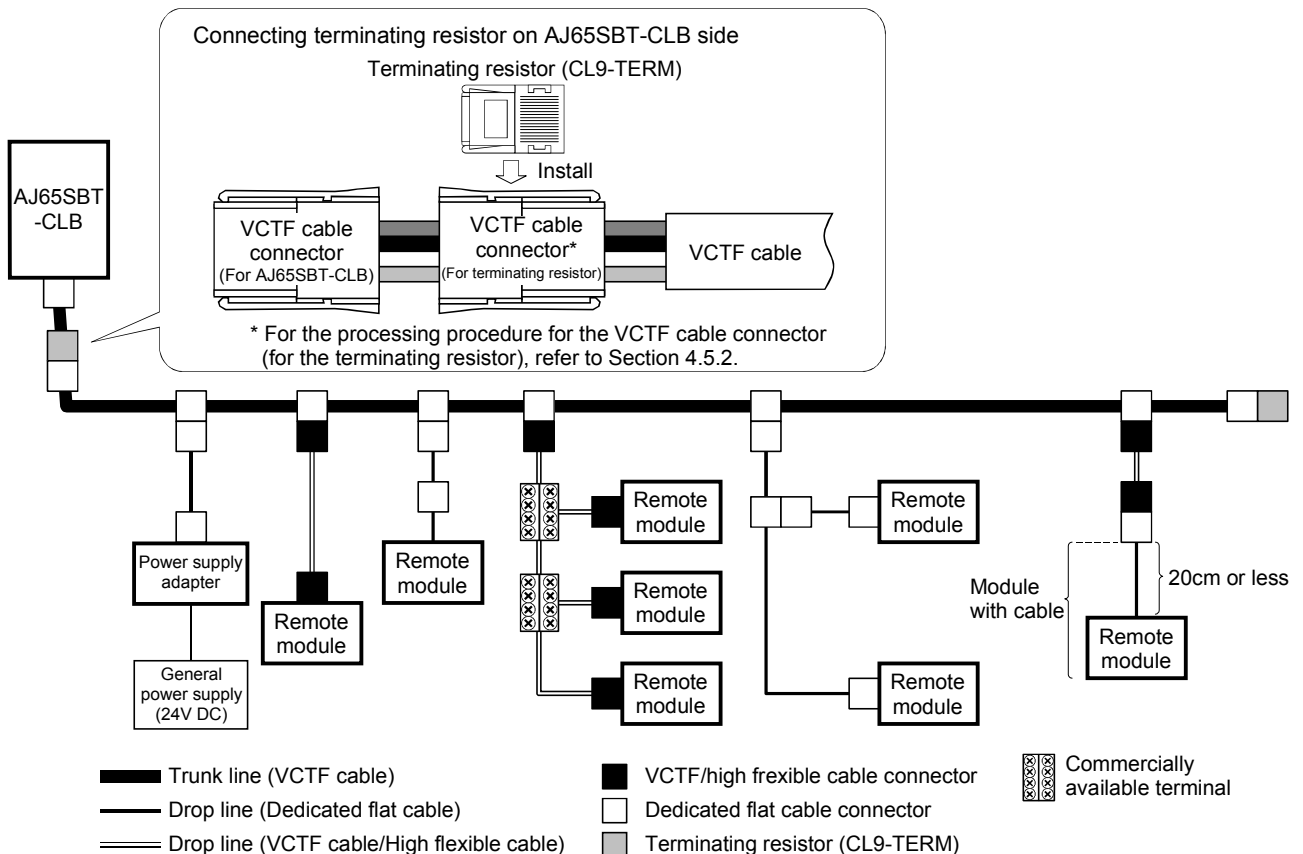

Fig. 4.2

(3) System configuration example for using dedicated flat cable as trunk line



(4) System configuration example for using VCTF cable as trunk line





(5) System configuration example for using high flexible cable as trunk line

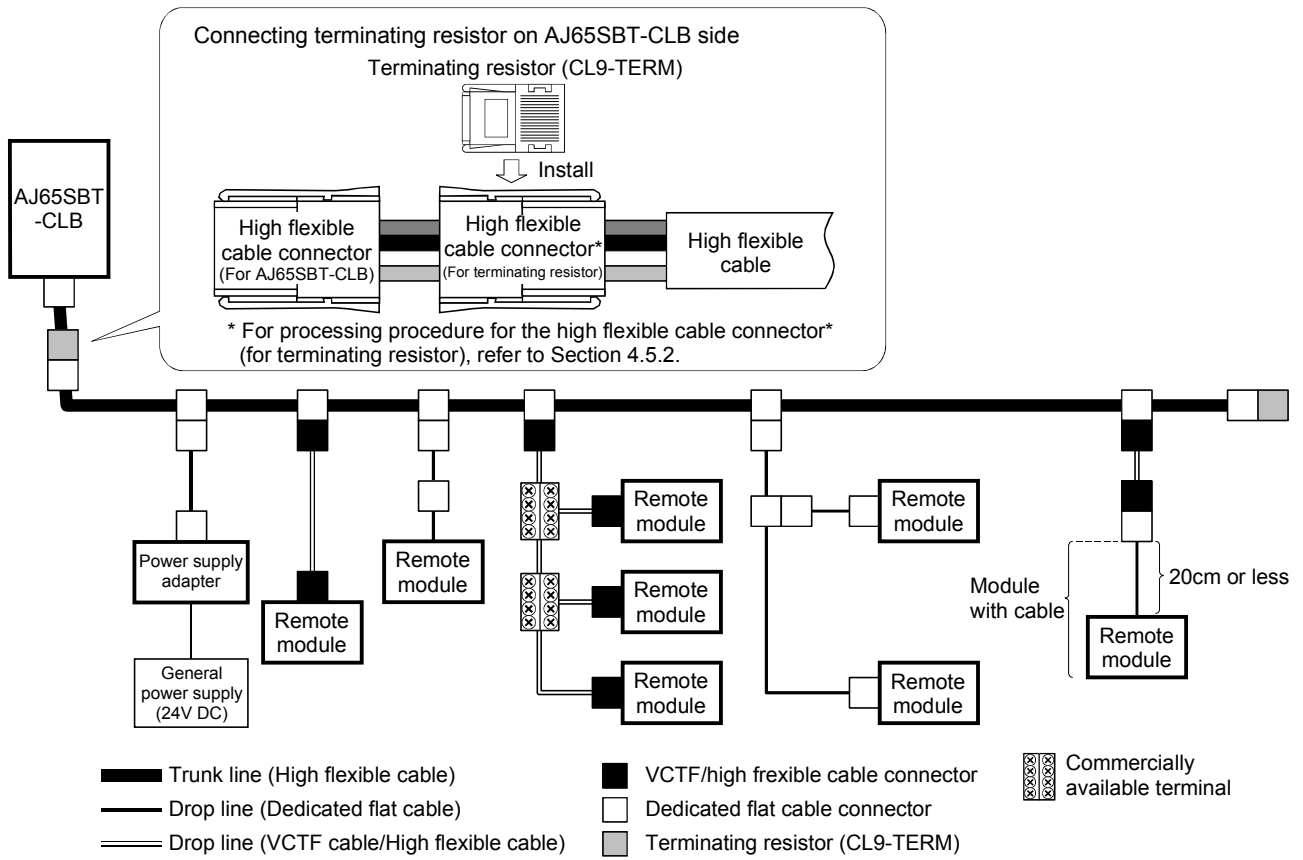

## 4.5.4 Mounting terminating resistors

Use the CL9-TERM (Gray) for the terminating resistor.

For the system configuration using the dedicated flat cables only, the CL9-RYVK (Black) can be also used. Note that the same type must be used for both ends of the trunk line.

(1) Mounting terminating resistor to AJ65SBT-CLB side

Mount the terminating resistor to the AJ65SBT-CLB side as shown below.

Note that it should be placed within 20 cm from the AJ65SBT-CLB.

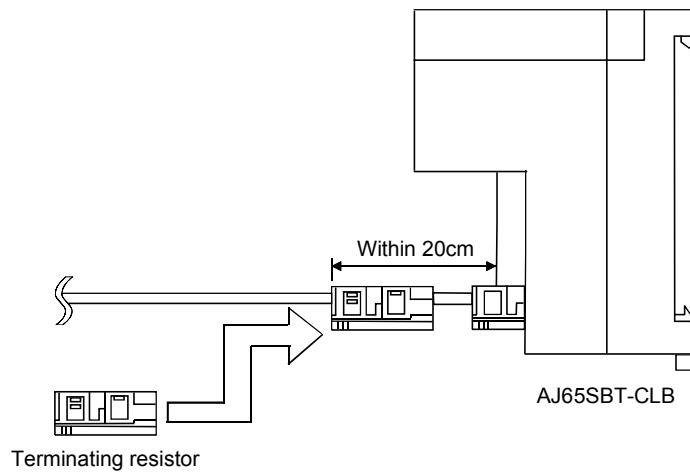

(2) Mounting terminating resistor to another end of trunk line

Mount the terminating resistor to the opposite end to the AJ65SBT-CLB side as shown below.

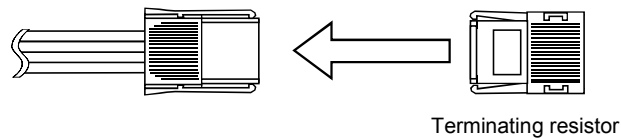

#### 4.6 CC-Link Side Connection

This section explains the wiring the CC-Link dedicated cables that connect the AJ65SBT-CLB and master module.

4.6.1 Connection of the CC-Link dedicated cables

Connect the CC-Link dedicated cable between the AJ65SBT-CLB and master module as shown below.

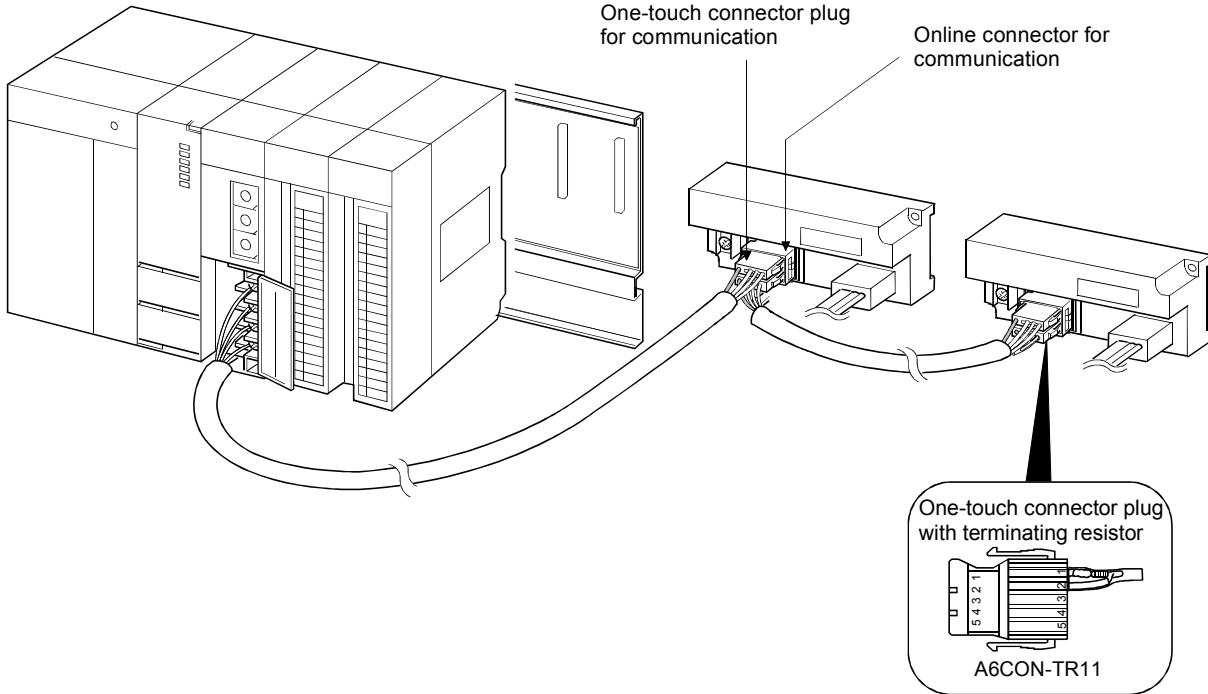

[CC-Link dedicated cable wiring diagram]

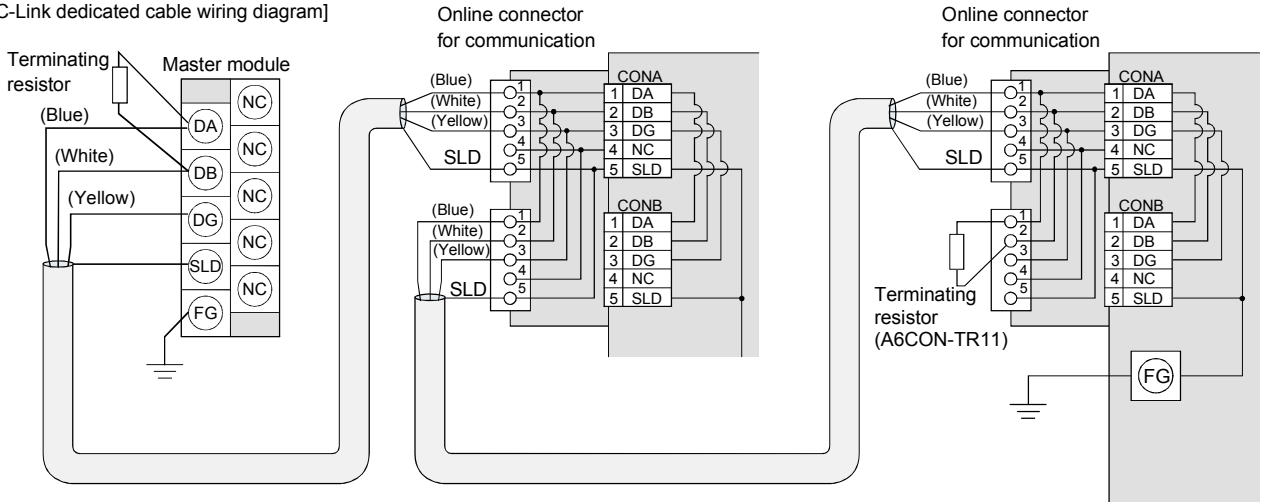

Ver.1.10 Compatible CC-Link dedicated cable (FANC-110SBH,CS-110,FA-CBL200PSBH)

**POINT**

- For this module, use the Ver. 1.10-compatible CC-Link dedicated cable (FANC-110SBH,CS-110,FA-CBL200PSBH).You cannot use the Ver. 1.10-compatible CC-Link dedicated cables, CC-Link dedicated cables or CC-Link dedicated, high-performance cables of other than the above models.
- The shield wire of the CC-Link dedicated cable should be connected to "SLD" in each module, and both ends should be grounded through "FG". "SLD" and "FG" are connected inside the module.

4.7 Wiring the One-Touch Connector Plug

This section describes wiring the one-touch connector plug.

Refer to section 2.4 for more information on the models and specifications of the one-touch connector plugs which comply to the AJ65SBT-CLB.

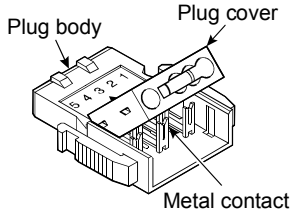

Cut the shield wire, aluminum tape and braid.

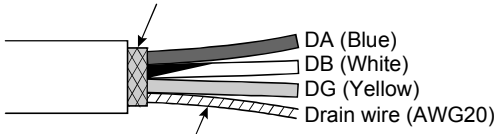

Stretch the drain wire and twist it from the base. (3cm in length, 7 times or more)

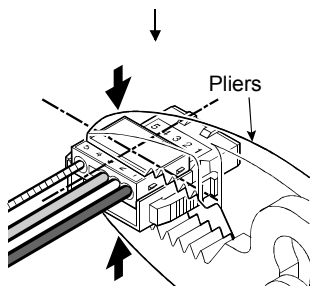
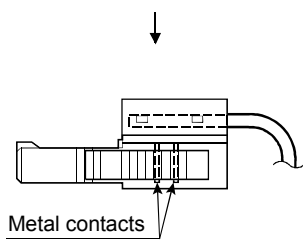
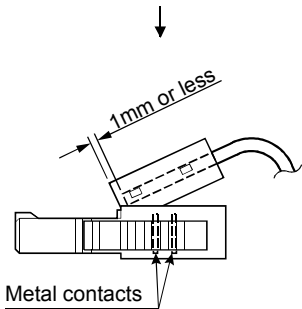

(To the next page)

- 1) Check the connector.  
Check that the plug cover is attached to the plug body.

Note: Do not push the plug cover into the plug body.  
Once pressed, the plug cannot be used any more.

- 2) Processing for communication cable  
Strip the cable 3cm or more and perform the processing indicated at left.  
If the electric wire lengths are not even, trim their ends with a nipper to the same length so as to insert them neatly into a connector.

- 3) Insert the cable.  
Lift the end of the plug cover and insert the cable until it almost reaches the plug body (within 1mm from the other end of the plug cover).  
Insufficient cable insertion may cause improper press fitting.

Note: When inserting the cable, prevent the cable from sticking out from the plug cover end.

- 4) Set the plug cover.  
After inserting the cable, put down the plug cover so that its face is horizontal to the plug surface, allowing the metal contacts to be fitted into the plug cover.

- 5) Press the center part of the plug cover.  
Using pliers, press the center part of the plug cover vertically and strongly.

For the one-touch connectors, use adjustable pliers so that their jaws can be widely opened.

(From the previous page)

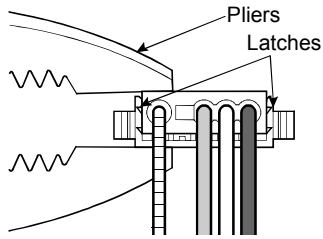

- 6) Press both ends of the plug cover  
After pressing the center part of the plug cover, press both ends of the plug cover where latches are located. Verify that the latches engage with the plug body.

[Correct example]

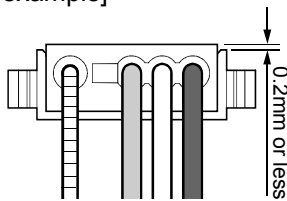

- 7) Check the press-fit condition (viewing from the wiring side). Viewing from the wiring side, check that the plug surface is flush with the plug cover. The difference between the plug cover and the plug surface must be 0.2mm or less.

[Wrong example]

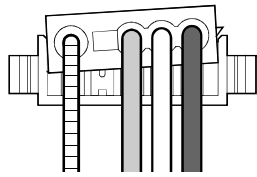

Note: The condition where the plug cover is tilted as shown in [Wrong example] or protrudes from the plug surface 0.2mm or more is an improper press-fit condition.  
Press the plug cover securely with pliers until it looks like [Correct example] condition illustrated on the left.

[Correct example]

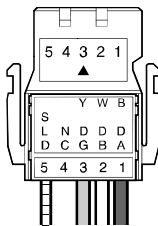

- 8) Check the press-fit condition (viewing from the top). Viewing from the top, check that there is no clearance between the plug body and plug cover.

Note: Clearance may occur between the plug body and plug cover when the latches do not engage securely as shown in [Wrong example]. Press the plug cover firmly with pliers until it looks like [Correct example] condition illustrated on the left.

[Wrong example]

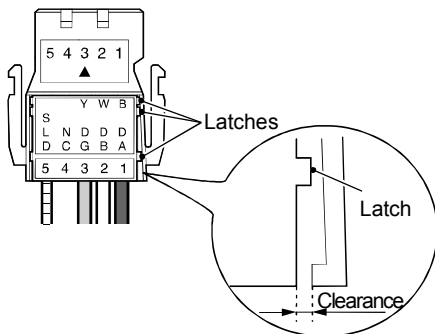

(Wiring completed)

## 4.8 Wiring Check

Check the wiring of the CC-Link/LT remote I/O stations and external devices.

[Wiring check example]

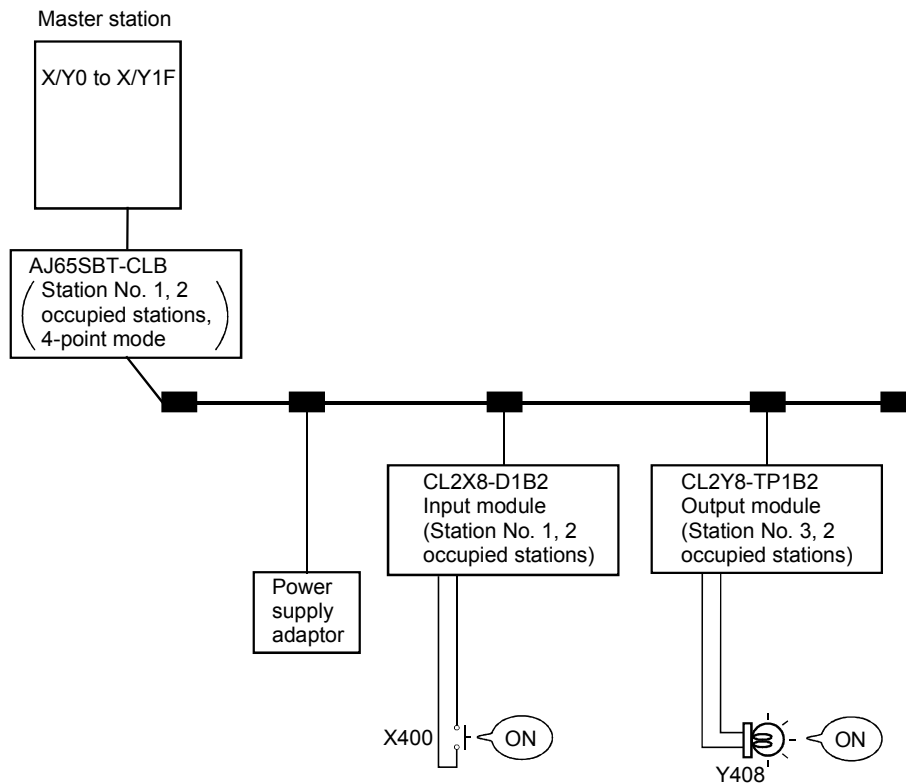

(1) When making auto refresh

After network parameter setting, set "Remote input (RX) refresh device" to "X400" and "Remote output (RY) refresh device" to "Y400".

(a) Checking the wiring of the input module and external device

- 1) Turn on the switch, which corresponds to "X400", of the external device connected to the input module of Station No. 1.
- 2) Using GX Developer, choose "Online" - "Monitor" - "Device batch", set "X400" in the "Device" field, and click Monitor Start.
- 3) When X400 is on, the connection of the input module and external device is normal.

(b) Checking the wiring of the output module and external device

- 1) Using GX Developer, choose "Online" - "Debug" - "Device test", set "Y408" in the "Device" field of "Bit device", and click "Forced ON".
- 2) If the connection of the output module and external device is normal, the lamp of the external device corresponding to "Y408" turns on.

**(2) When making refresh with FROM/TO instruction**

After network parameter setting, refresh RX/RV to X400/Y400 using the FROM/TO instruction.

**(a) Data link start**

The operation in this section is not required when the network parameters have been set using GX Developer or dedicated instruction.

- 1) Using GX Developer, choose "Online" - "Debug" - "Device test, set "Y0" in the "Device" field of "Bit device", and click Forced ON.
- 2) Using GX Developer, choose "Online" - "Debug" - "Device test, set "Y6" in the "Device" field of "Bit device", and click "Forced ON".
- 3) Using GX Developer, choose "Online" - "Monitor" - "Device batch", set "X6" in the "Device" field, and click Monitor Start.
- 4) When X6 is on, a data link start has been completed normally.
- 5) Using GX Developer, choose "Online" - "Debug" - "Device test, set "Y6" in the "Device" field of "Bit device", and click "Forced ON".

**(b) Checking the wiring of the input module and external device**

- 1) Turn on the switch, which corresponds to "X400", of the external device connected to the input module of Station No. 1.
- 2) Using GX Developer, choose "Online" - "Monitor" - "Device batch", set "X400" in the "Device" field, and click Monitor Start.
- 3) When X400 is on, the connection of the input module and external device is normal.

**(c) Checking the wiring of the output module and external device**

- 1) Using GX Developer, choose "Online" - "Debug" - "Device test, set "Y408" in the "Device" field of "Bit device", and click "Forced ON".
- 2) When the connection of the output module and external device is normal, the lamp of the external device corresponding to "Y408" turns on.

**4.9 Maintenance and Inspection**

There are no special inspection items for the AJ65SBT-CLB module, but follow the inspection items described in the programmable controller CPU User's Manual so that the system always works in the best condition.



## 5 PROGRAMMING

This chapter explains the programming of the AJ65SBT-CLB.

When applying any of the program examples introduced in this chapter to the actual system, verify the applicability and confirm that no problems will occur in the system control.

Refer to the user's manual of the master module for details of that module, to Section 3.7 for the remote registers, and to the AnSHCPU/AnACPU/AnUCPU/QCPU-A (A Mode) Programming Manual (Dedicated Instructions) for details of the dedicated instructions.

### 5.1 Conditions of Program Examples

The program examples in this chapter are based on the following conditions.

#### (1) System configuration

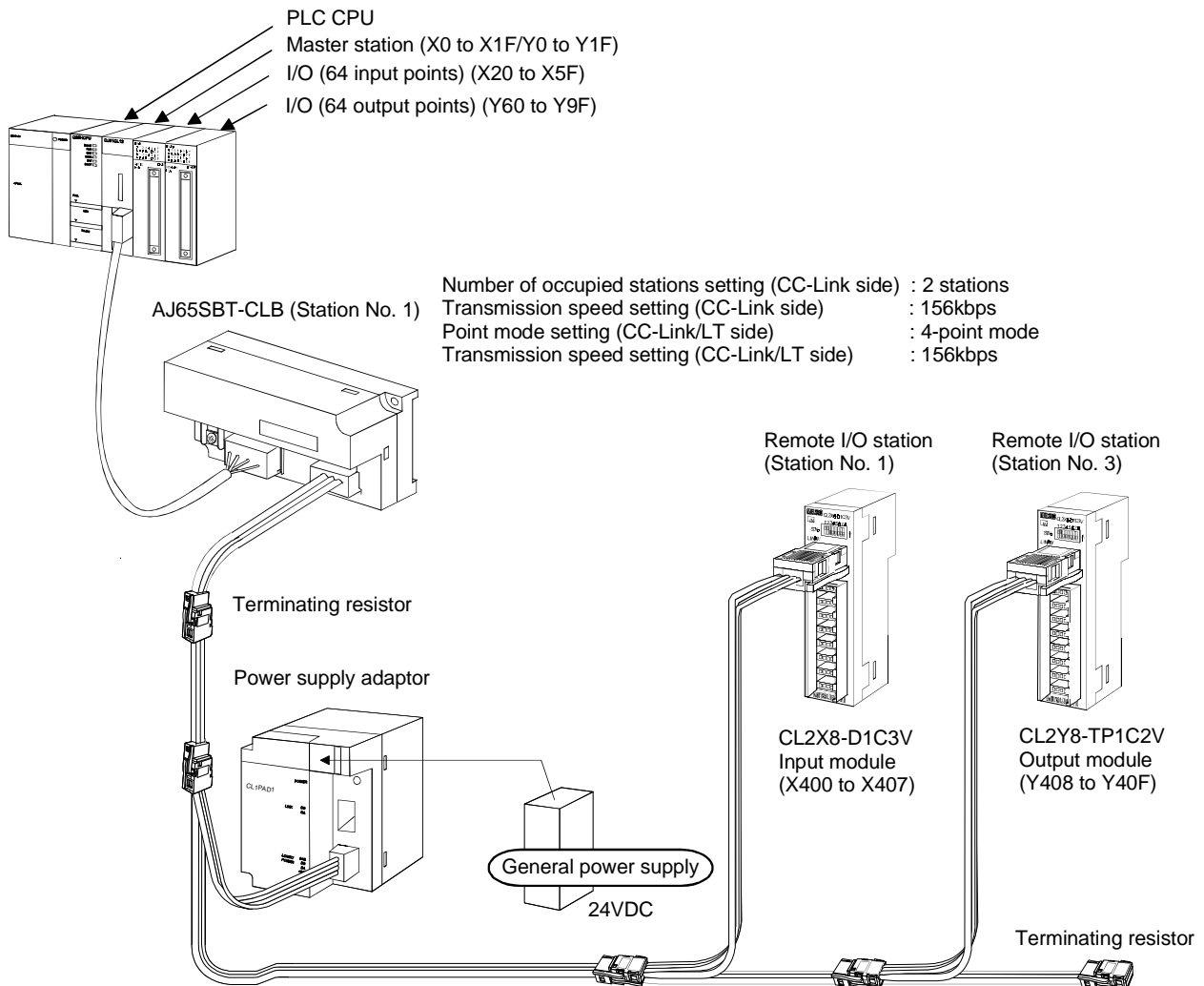

(2) Relation between PLC CPU, CC-Link master station, AJ65SBT-CLB and CC-Link/LT remote I/O stations

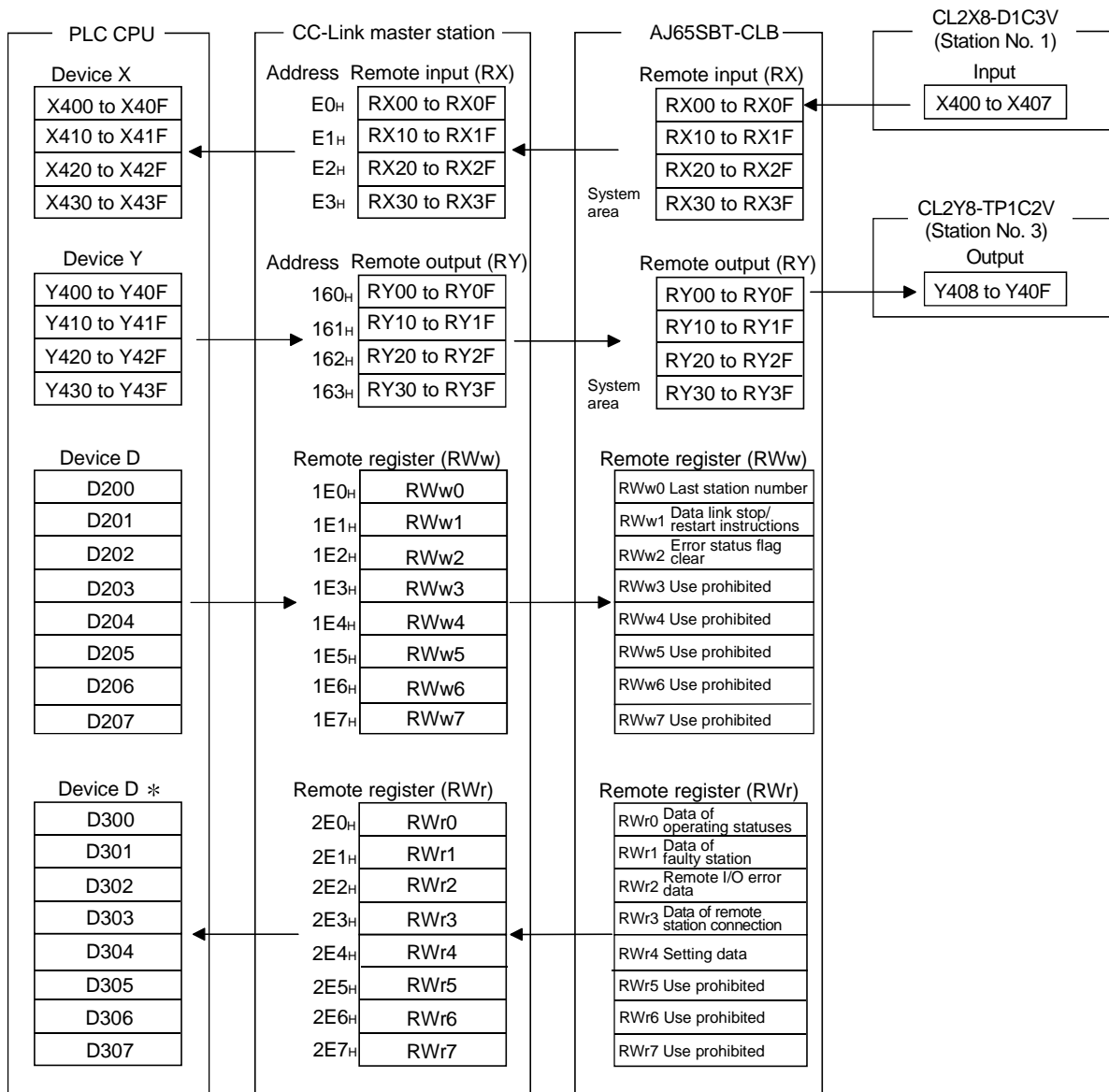

\* In the program example created with the RRPA instruction (auto refresh parameter setting) on the ACPU/QCPU (A mode), RWr0 - RWr7 are assigned to D456 to D463.

**POINT**

Depending on the CPU module, the devices used in the program examples of this chapter may be unusable. For the valid ranges of the devices, refer to the users' manual of the CPU module.  
 For example, when the A1SCPU is used, devices of X100, Y100 and later cannot be used. Use the devices such as B and M.

5

### (3) Devices used by the user

The devices used by the user are indicated below.

Data link stop instruction signal .....	X21
Data link restart instruction signal .....	X22
CC-Link side data link error confirmation signal .....	Y90
CC-Link/LT side remote station connection error confirmation signal ....	Y91
CC-Link/LT side data link error confirmation signal .....	Y92
CC-Link/LT side all station fault confirmation signal .....	Y93
CC-Link/LT side remote I/O error confirmation signal .....	Y94
CC-Link side data link status read flag.....	M0
RLPA instruction execution flag .....	M10
RLPA instruction normally completed flag .....	M11
RLPA instruction abnormally completed flag .....	M12
RRPA instruction execution flag.....	M13
Network parameter setting flag .....	M20
CC-Link side data link normal flag.....	M100
Control start flag.....	M101
Operation status data read flag .....	M200 to M215
Data link stop instruction flag.....	M300
Data link restart instruction flag .....	M315

5.2 Program Example for Use of QCPU (Q Mode)

The network parameters and auto refresh parameters are set using GX Developer.

(1) Parameter setting

(a) Network parameter setting

Start I/O No	1	0000
Operational setting	Operational settings	
Type	Master station	▼
Master station data link type	PLC parameter auto start	▼
Mode	Online (Remote net mode)	▼
All connect count		1
Remote input(RX)		
Remote output(RY)		
Remote register(RW/r)		
Remote register(RW/w)		
Special relay(SB)		
Special register(SW)		
Retry count		3
Automatic reconnection station count		1
Stand by master station No.		
PLC down select	Stop	▼
Scan mode setting	Asynchronous	▼
Delay information setting		0
Station information setting	Station information	
Remote device station initial setting	Initial settings	
Interrupt setting	Interrupt settings	

Station No.	Station type	Exclusive station count	Reserve/invalid station select	Intelligent buffer select(word)		
				Send	Receive	Automatic
1/1	Remote device station ▼	Exclusive station 2 ▼	No setting ▼			

(b) Automatic refresh parameter setting

Start I/O No	1	0000
Operational setting	Operational settings	
Type	Master station	▼
Master station data link type	PLC parameter auto start	▼
Mode	Online (Remote net mode)	▼
All connect count		1
Remote input(RX)		X400
Remote output(RY)		Y400
Remote register(RW/r)		D300
Remote register(RW/w)		D200
Special relay(SB)		SB0
Special register(SW)		SW0
Retry count		3
Automatic reconnection station count		1
Stand by master station No.		
PLC down select	Stop	▼
Scan mode setting	Asynchronous	▼
Delay information setting		0
Station information setting	Station information	
Remote device station initial setting	Initial settings	
Interrupt setting	Interrupt settings	

(2) Program example

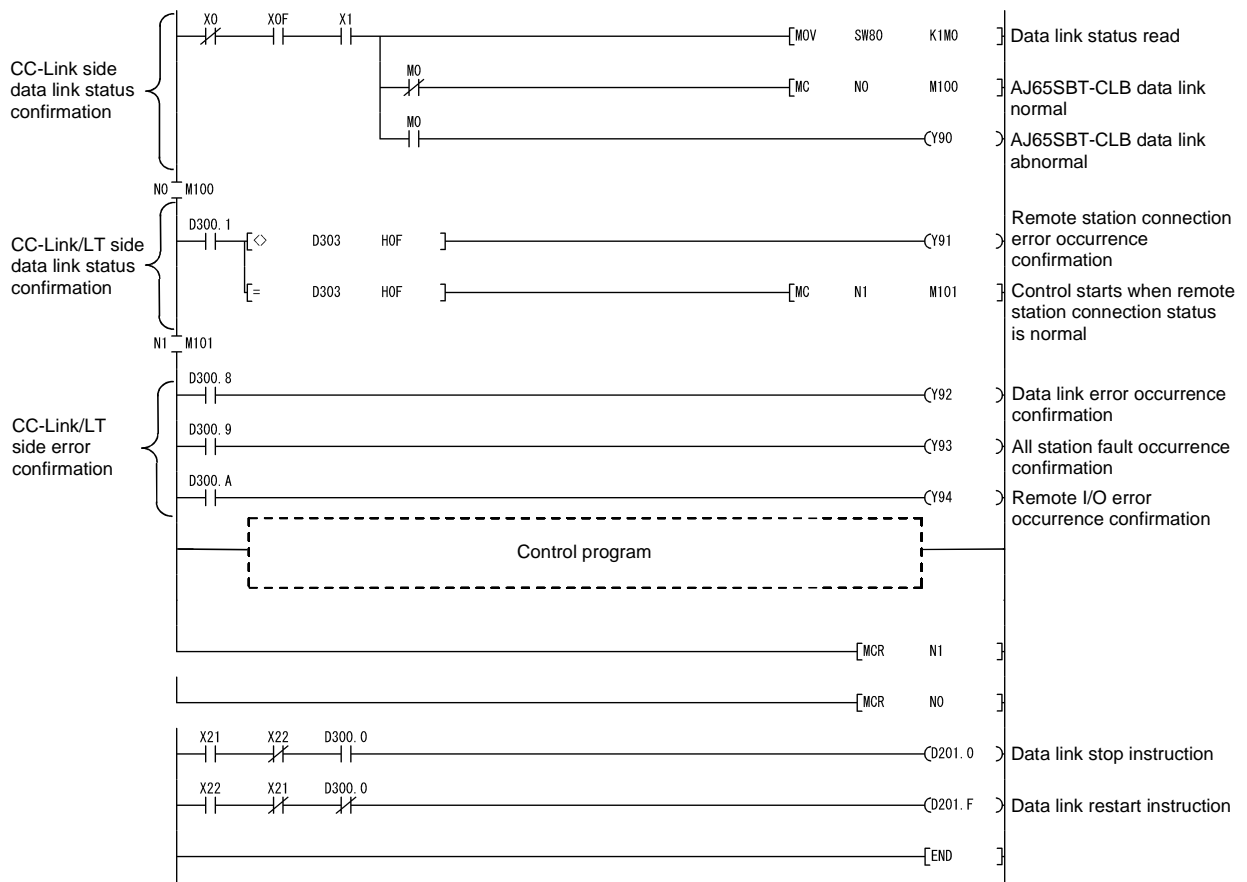

5.3 Program Example for Use of QnACPU

The network parameters and auto refresh parameters are set using GX Developer.

(1) Parameter setting

(a) Network parameter setting

	1
Start I/O No.	0000
Type	Master station ▼
All connect count	1
Remote input(RX)	
Remote output(RY)	
Remote register(RWr)	
Remote register(RWw)	
Special relay(SB)	
Special register(SW)	
Retry count	3
Automatic reconnection station count	1
Wait master station No.	0
PLC down select	Stop ▼
Scan mode setting	Asynchronously ▼
Delay information setting	0
Station information setting	Station information

StationNo.	Station type	Exclusive station count	Reserve/invalid station select	Intelligent buffer select(word) ▲		
1/1	Remote device station ▼	Exclusive station 2 ▼	No setting ▼	Send	Receive	Automatic ▼

(b) Automatic refresh parameter setting

	1
Start I/O No.	0000
Type	Master station ▼
All connect count	1
Remote input(RX)	X400
Remote output(RY)	Y400
Remote register(RWr)	D300
Remote register(RWw)	D200
Special relay(SB)	B0
Special register(SW)	w0
Retry count	3
Automatic reconnection station count	1
Wait master station No.	0
PLC down select	Stop ▼
Scan mode setting	Asynchronously ▼
Delay information setting	0
Station information setting	Station information

(2) Program example

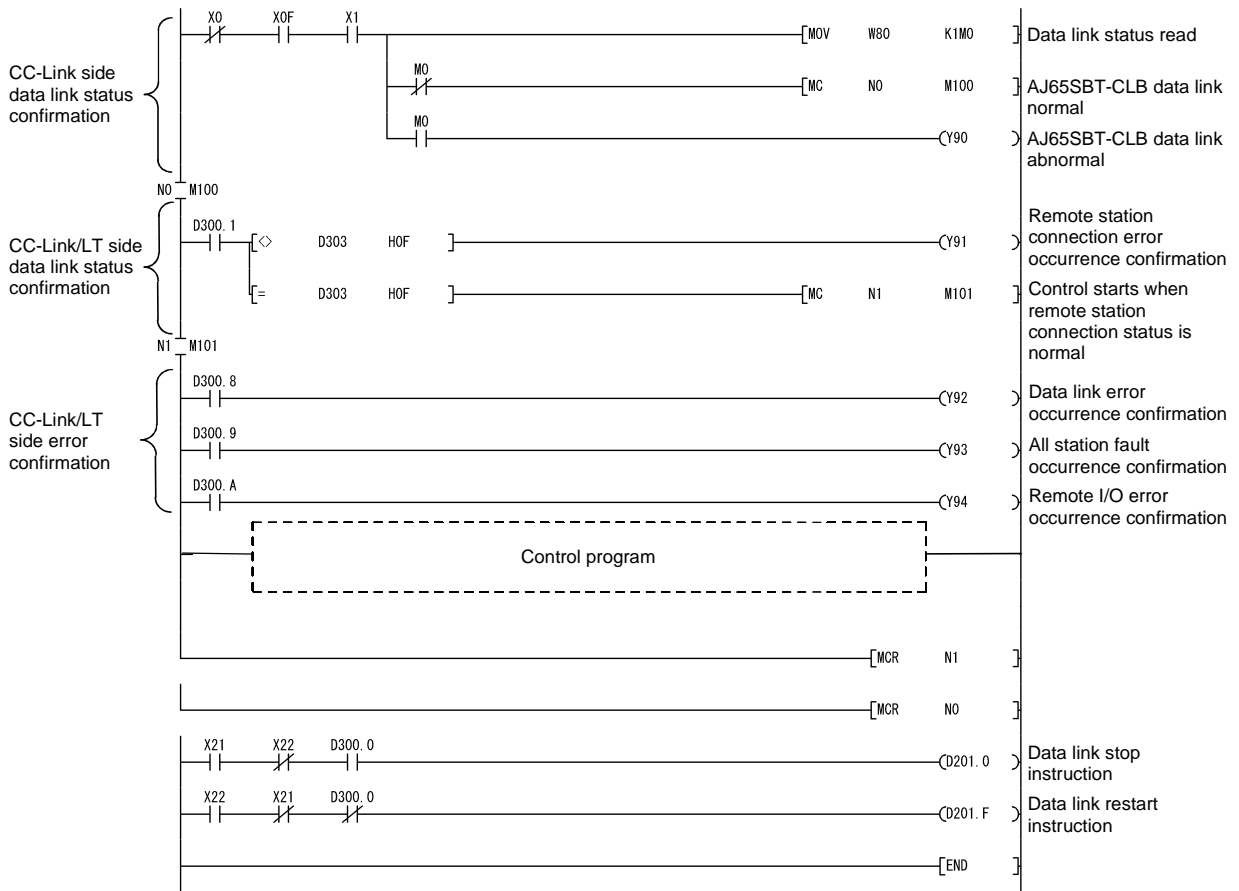

5.4 Program Example for Use of ACPU/QCPU (A Mode) (Dedicated Instructions)

The network parameters and auto refresh parameters are set using a sequence program.

(1) Program example

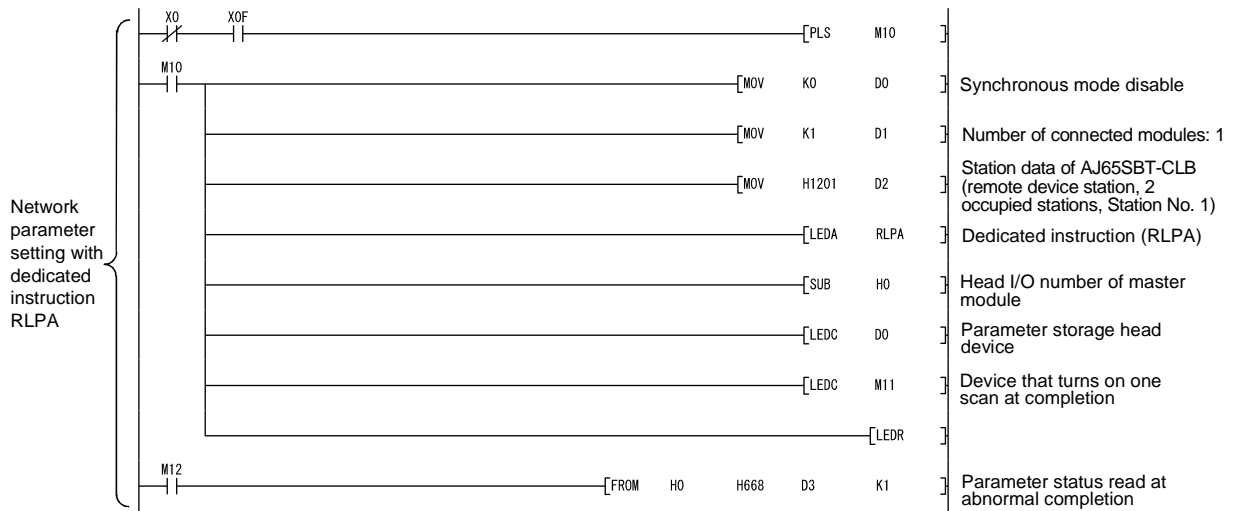



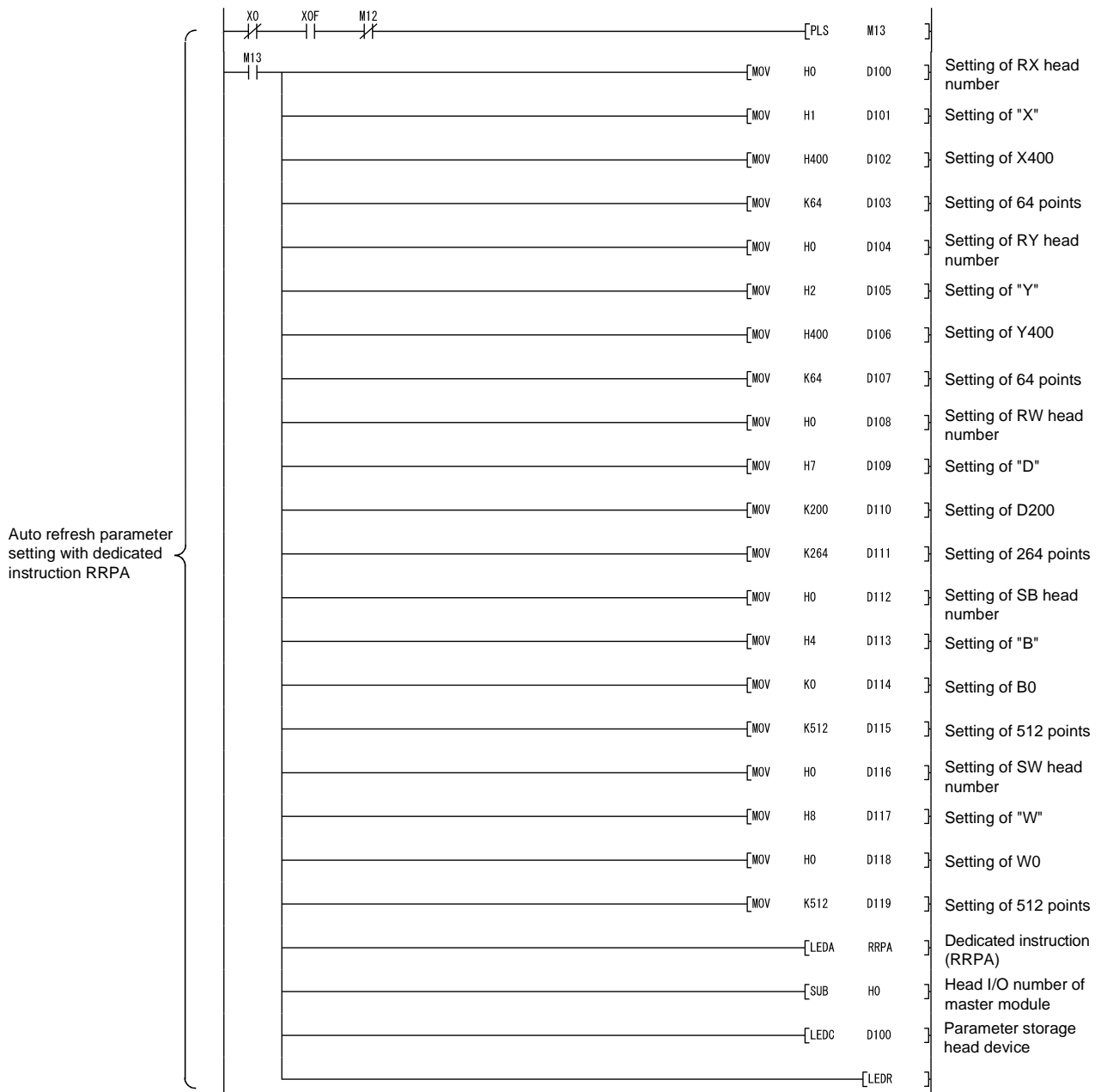

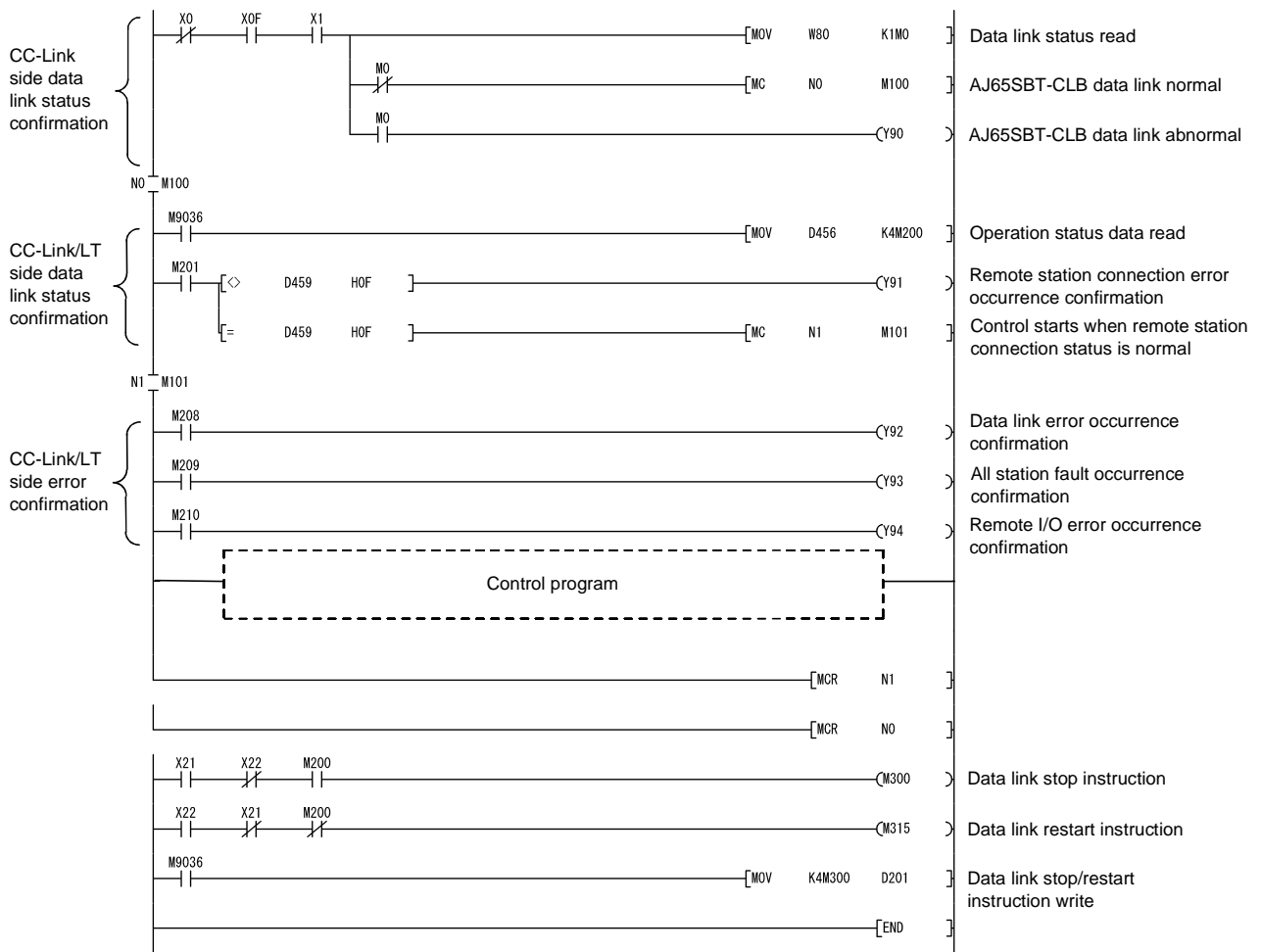

5.5 Program Example for Use of ACPU/QCPU (A Mode) (FROM/TO Instructions)

The network parameters are set using a sequence program.

(1) Program example

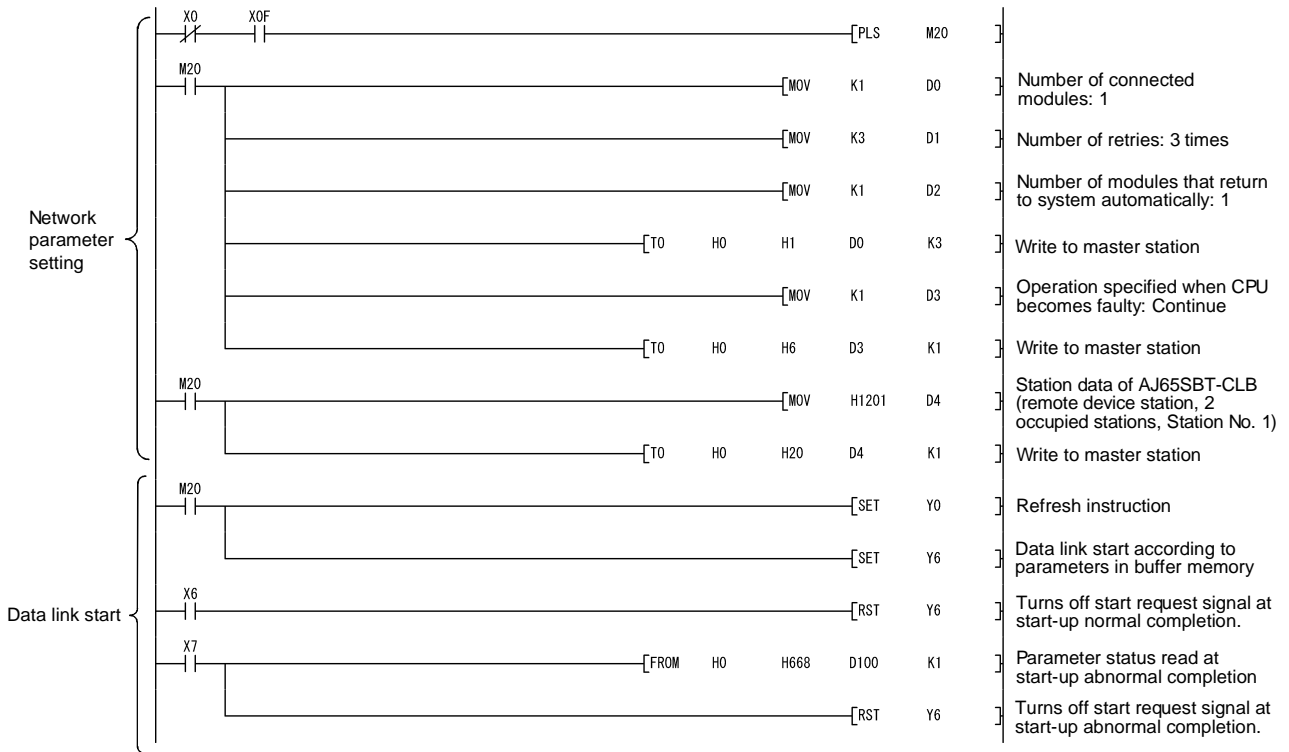

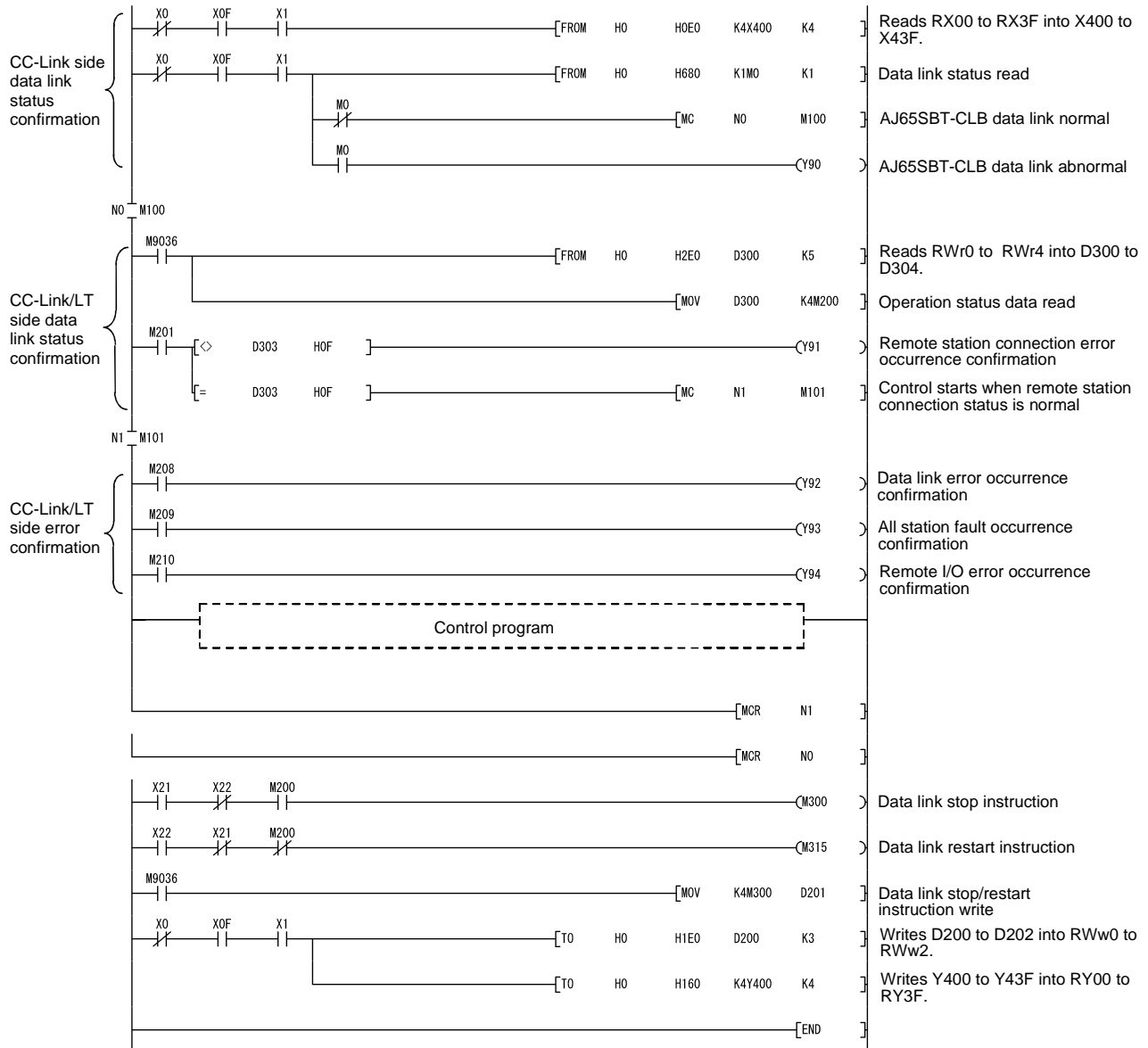

## 6 TROUBLESHOOTING

This chapter explains troubleshooting.

### 6.1 Station Status at Error Occurrence

The following table indicates the station status at error occurrence.

Error Condition	CC-Link Master Station		CC-Link/LT Remote I/O Station	
	Input RX	Output RY	Input	Output
When a communication error occurs between the CC-Link master station and AJ65SBT-CLB	Clear/hold *1	Continue	Continue	Clear/hold *2
When a communication error occurs between the AJ65SBT-CLB and CC-Link/LT remote I/O station	Clear	Continue	Continue	Clear/hold *2

\*1: Depending on the switch setting of the CC-Link master station.

\*2: Depending on the switch setting of the CC-Link/LT remote I/O station.

6.2 Troubleshooting Flow

This section explains error definitions by phenomenon.

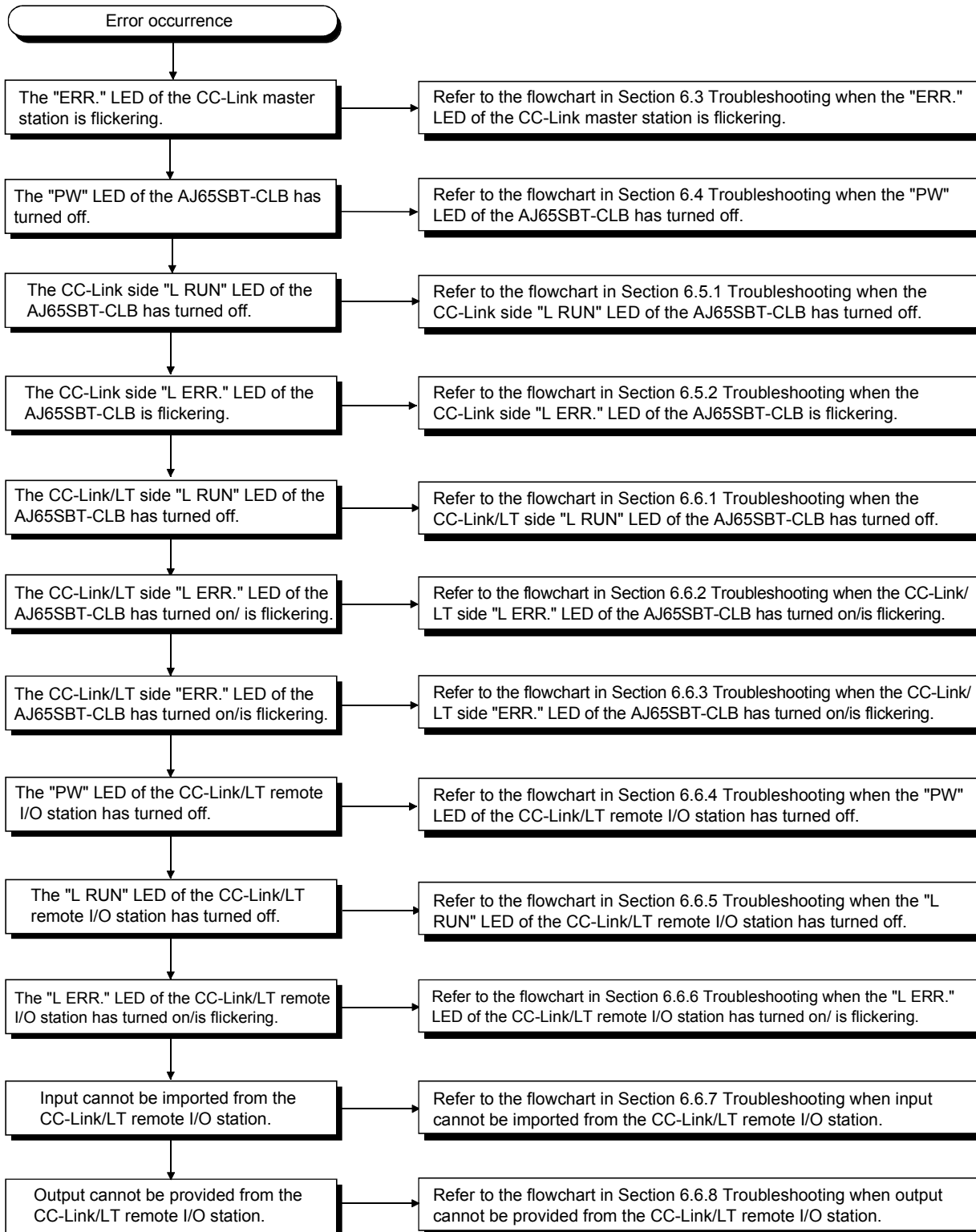

6.3 Troubleshooting when the "ERR" LED on the Master Station is Flashing

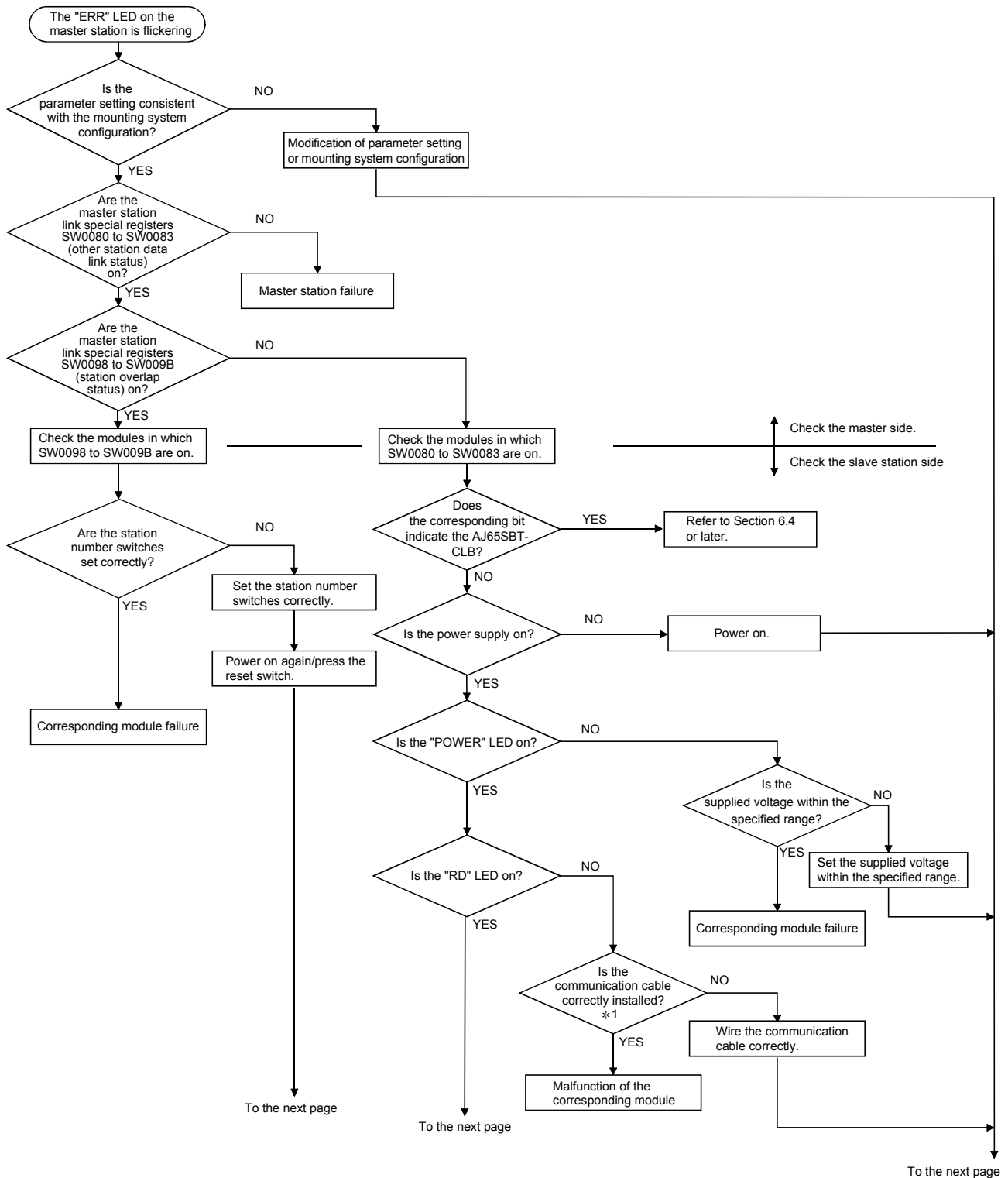

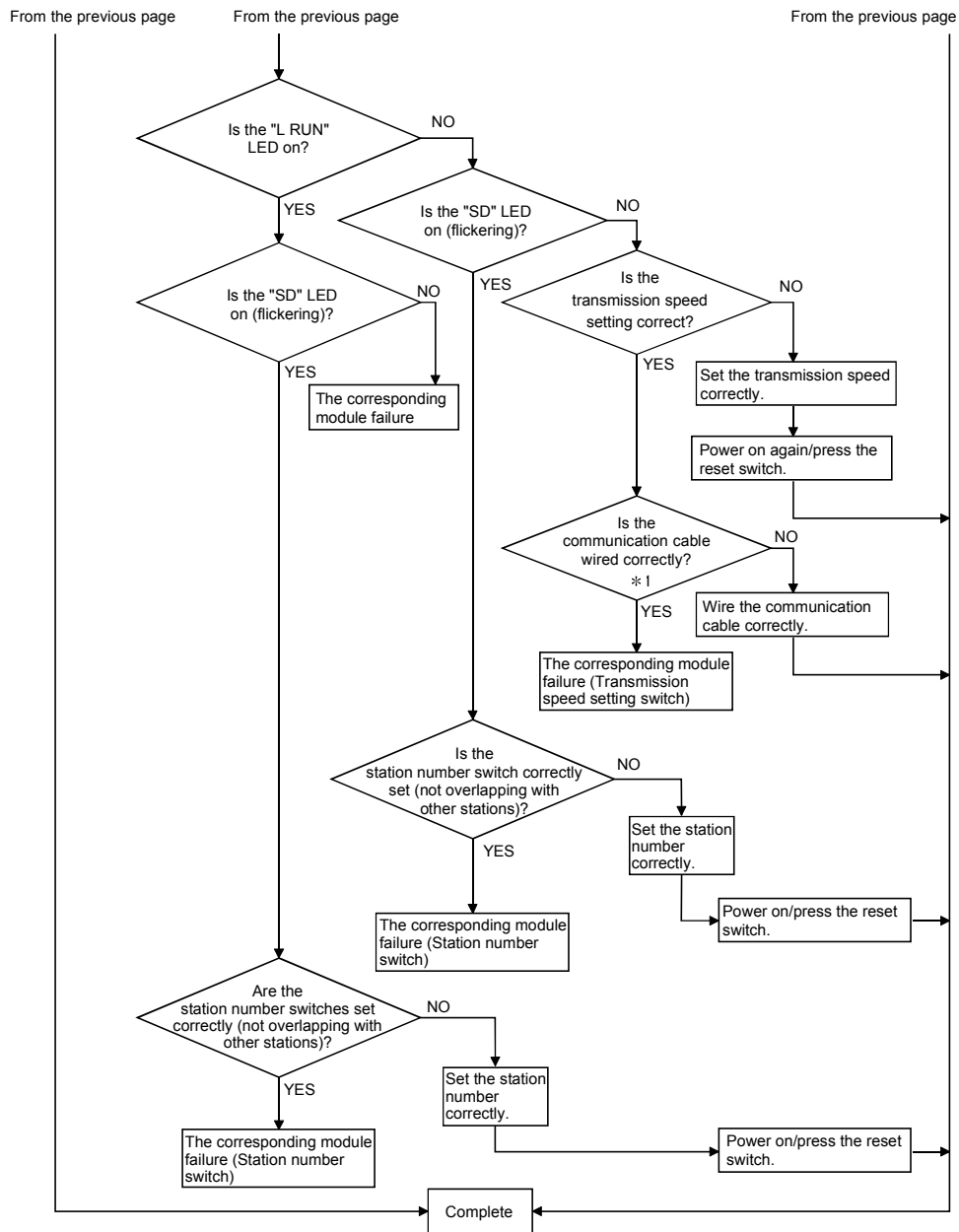

\*1 : Check for a short, reversed connection, wire breakage, terminating resistor, FG connection, overall distance and station-to-station distance.



6.4 Troubleshooting when the "PW" LED of the AJ65SBT-CLB has Turned Off

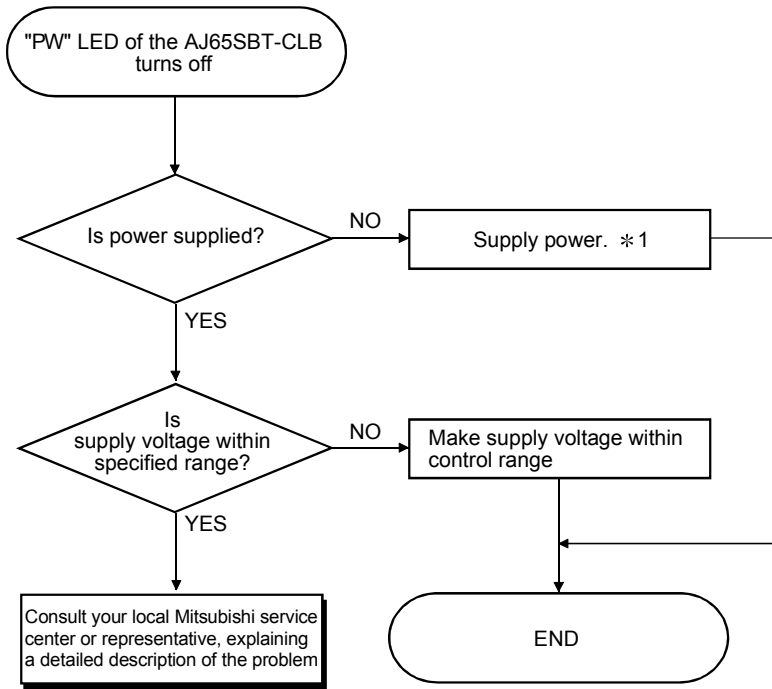

\* 1: Check for short circuit, inverse connection, cable break or excessive pressure to a cable.

\* 2: Measure the voltage using the check terminals of the terminating resistors.

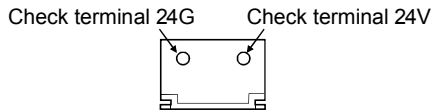

6.5 CC-Link Side Troubleshooting

6.5.1 Troubleshooting when the CC-Link side "L RUN" LED of the AJ65SBT-CLB has turned off

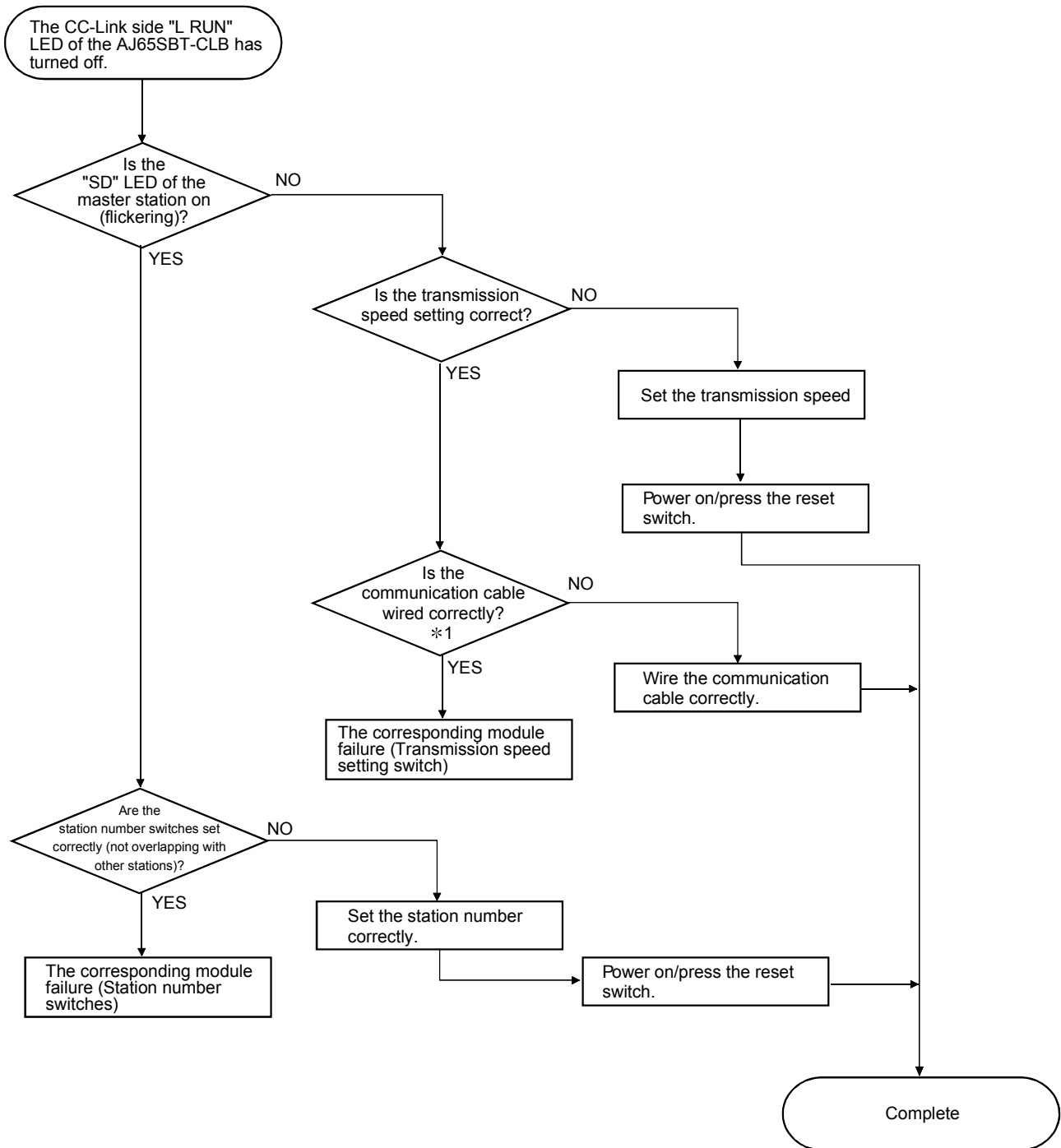

\*1 : Check for a short, reversed connection, wire breakage, terminating resistors, FG connection, overall distance and station-to-station distance.

6.5.2 Troubleshooting when the CC-Link side "L ERR." LED of the AJ65SBT-CLB is flickering

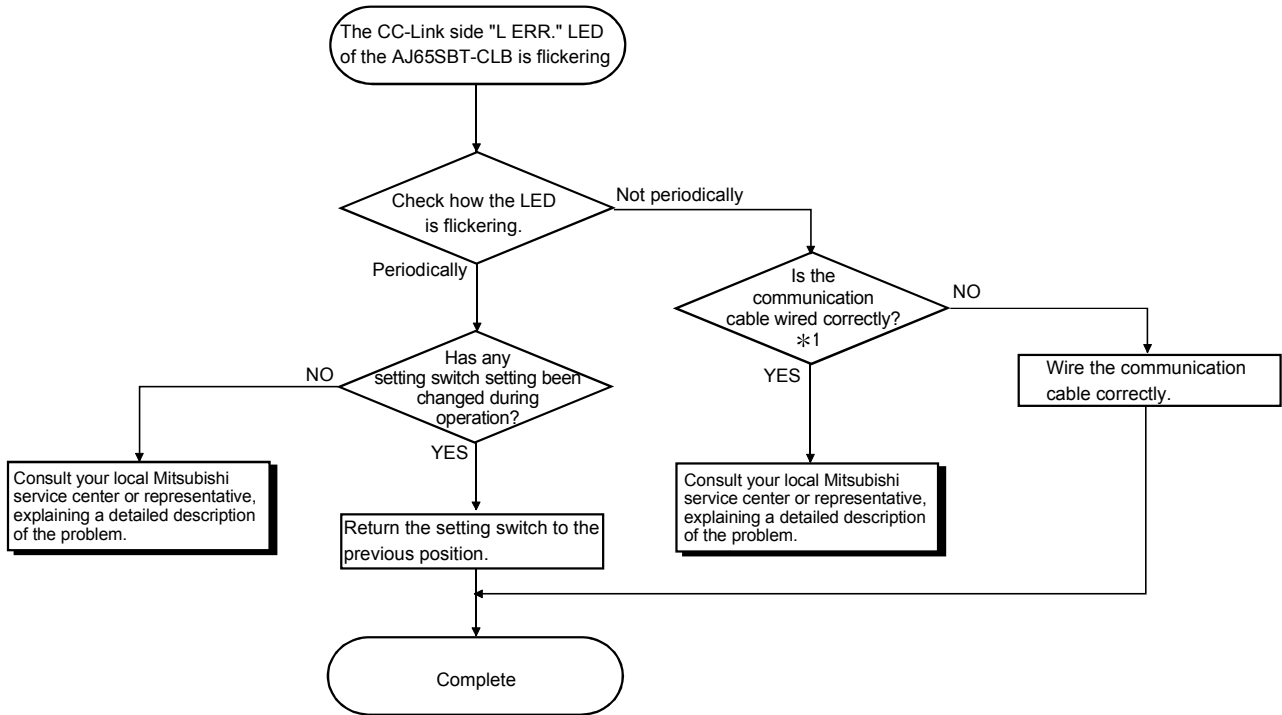

1 : Check for a short, reversed connection, wire breakage, terminating resistors, FG connection, overall distance and station-to-station distance.

## 6.6 CC-Link/LT Side Troubleshooting

## 6.6.1 Troubleshooting when the CC-Link/LT side "L RUN" LED of the AJ65SBT-CLB has turned off

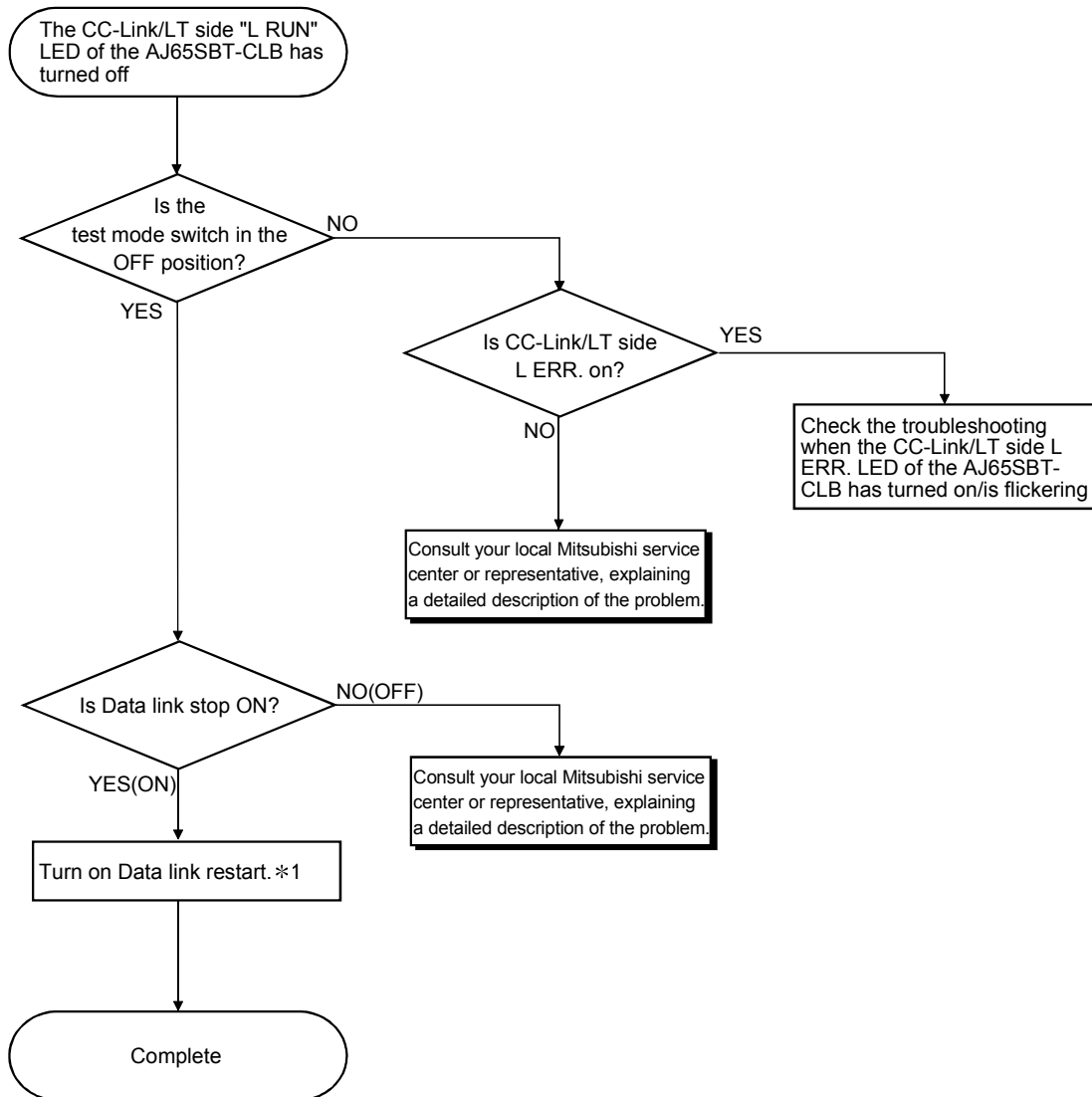

\* 1 : When Data link restart and stop are turned on simultaneously, Data link stop has higher priority.

6.6.2 Troubleshooting when the CC-Link/LT side "L ERR." LED of the AJ65SBT-CLB has turned on/is flickering

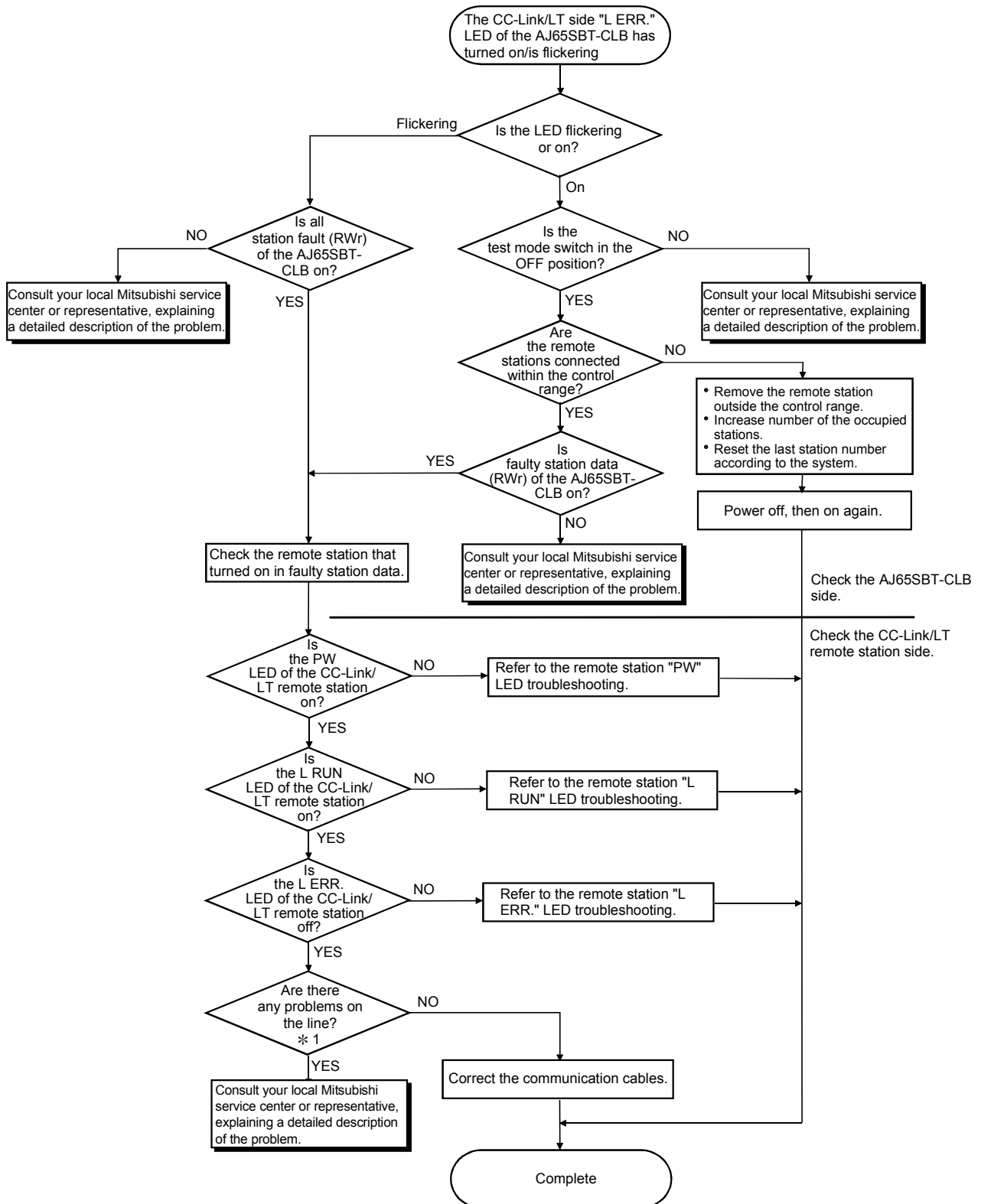

\*1: Check for a short, reversed connection, wire breakage, mixed cables, terminating resistors, overall distance, drop line distance (overall drop line length, maximum drop line length) and peripheral environment.

6.6.3 Troubleshooting when the CC-Link/LT side "ERR." LED of the AJ65SBT-CLB has turned on/is flickering

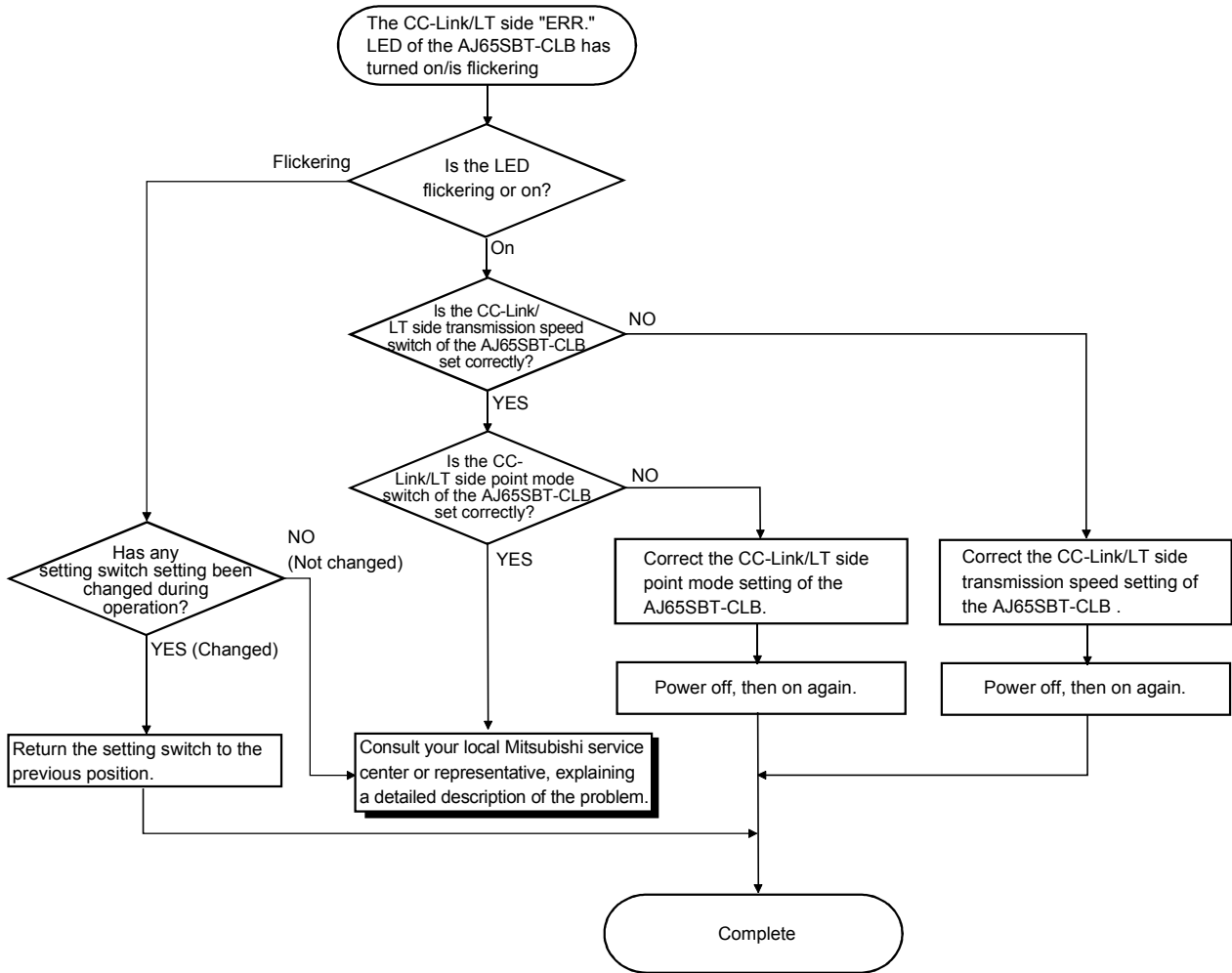

6.6.4 Troubleshooting when the "PW" LED of the CC-Link/LT remote I/O station has turned off

For troubleshooting of the remote device station, refer to the user's manual for your remote device station.

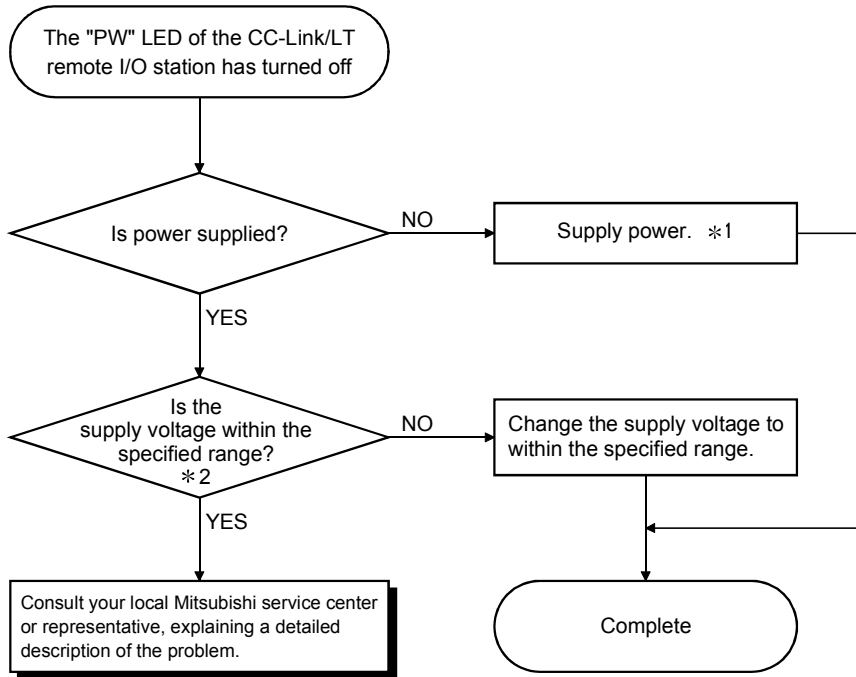

\* 1 : Check for a short, reversed connection, wire breakage and insulation displacement status.

\* 2 : Measure the voltage using the check terminals of the terminating resistors.

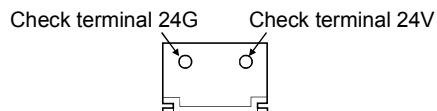

### 6.6.5 Troubleshooting when the "L RUN" LED of the CC-Link/LT remote I/O station has turned off

For troubleshooting of the remote device station, refer to the user's manual for your remote device station.

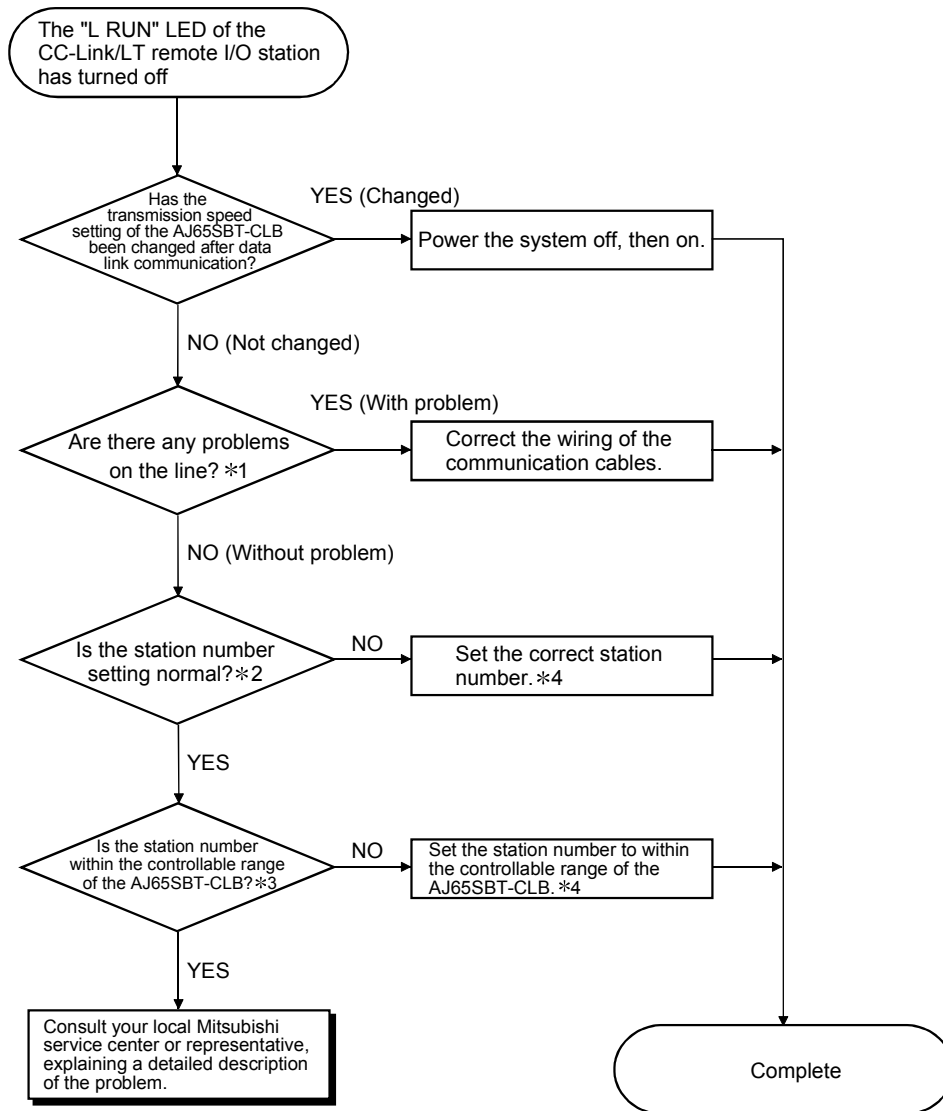

\*1 : Check for a short, reversed connection, wire breakage, insulation displacement status, terminating resistors, overall distance, drop line distance (overall drop line length, maximum drop line length) and peripheral environment (noise, etc.).

\*2 : Note the following.

- Any of 0 to 9 should be in the units digit.
- The switch should not be mistaken for the output hold setting switch or response speed setting switch.

\*3 : All station numbers occupied by the host module should be within the controllable range of the AJ65SBT-CLB. (Refer to Section 3.6.2)

\*4 : When the station number setting of the remote I/O station has been changed, power the whole system off, then on.



### 6.6.6 Troubleshooting when the "L ERR." LED of the CC-Link/LT remote I/O station has turned on/is flickering

For troubleshooting of the remote device station, refer to the user's manual for your remote device station.

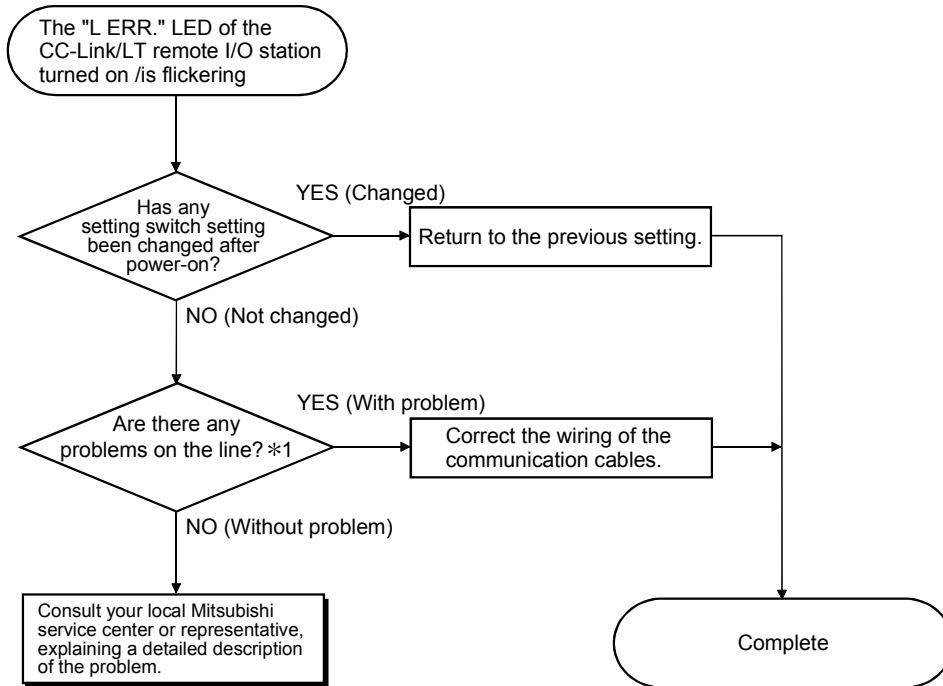

\*1 : Check for a short, reversed connection, wire breakage, insulation displacement status, terminating resistors, overall distance, drop line distance (overall drop line length, maximum drop line length) and peripheral environment (noise, etc.).

6.6.7 Troubleshooting when input cannot be imported from the CC-Link/LT remote I/O station

For troubleshooting of the remote device station, refer to the user's manual for your remote device station.

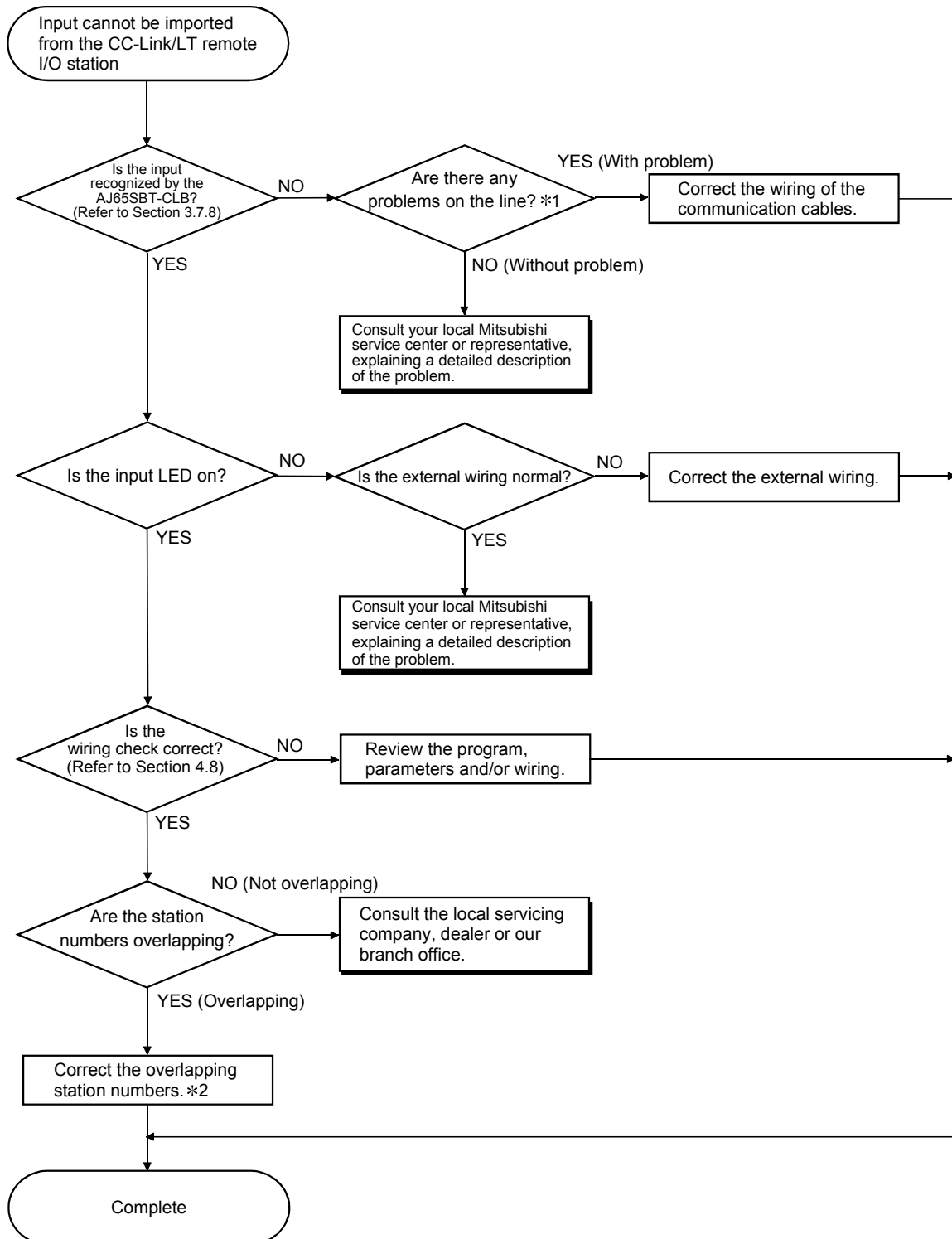

\*1 : Check for a short, reversed connection, wire breakage, insulation displacement status, terminating resistors, overall distance, drop line distance (overall drop line length, maximum drop line length) and peripheral environment (noise, etc.).  
 \*2 : When the station number setting of the remote I/O station has been changed, power the whole system off, then on.

6.6.8 Troubleshooting when output cannot be provided from the CC-Link/LT remote I/O station

For troubleshooting of the remote device station, refer to the user's manual for your remote device station.

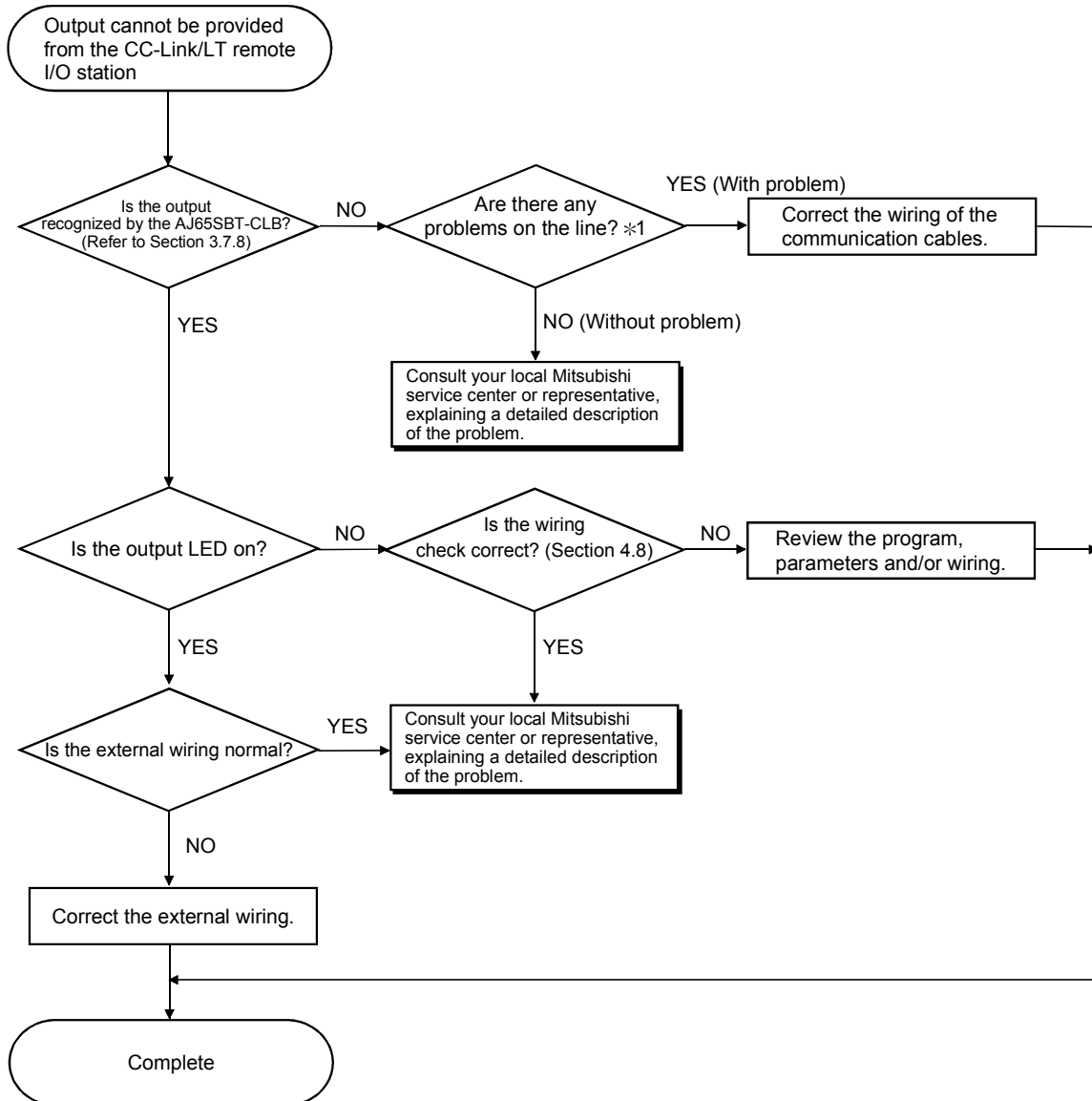

\*1 : Check for a short, reversed connection, wire breakage, insulation displacement status, terminating resistors, overall distance, drop line distance (overall drop line length, maximum drop line length) and peripheral environment (noise, etc.).

## 6.7 CC-Link / CC-Link/LT Diagnostics Using GX Developer

After connecting all the modules with connection cables, check the status of each module to see if data link can be performed.

Data link can also be performed when the master module is mounted on the remote I/O station of MELSECNET/H.

## (1) Line Monitor [Host station]

The data link status, etc. of the AJ65SBT-CLB are monitored.

## (a) Operation procedure

Choose [Diagnostics] → [CC-Link / CC-link/LT diagnostics].

- 1) In "Module Setting" box, select "CC-Link"
- 2) In the "Module No." or "I/O Address" box, specify the master module connected with the AJ65SBT-CLB for which Line Monitor will be executed.
- 3) Check the "CC-Link Bridge" check box. At this time, the station number of the AJ65SBT-CLB is searched for.
- 4) In the "Station" box, select the station number of the AJ65SBT-CLB for which Line Monitor will be executed.
- 5) Click the **Start Monitoring** button.

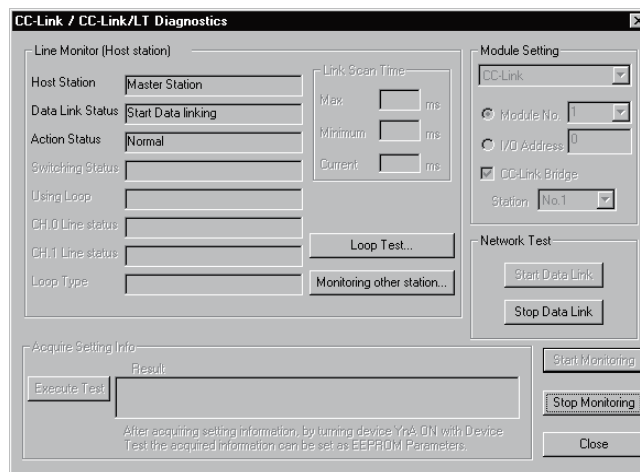

## (b) Monitor items

## 1) Host Station

Shows that the station being monitored is the AJ65SBT-CLB. (The AJ65SBT-CLB is displayed as the master station.)

## 2) Data Link Status

Shows the data link status of the AJ65SBT-CLB.

Start Data linking: Data link start status

Stop Data linking: Data link stop status

Initial comm. incomplete: Initial communication incomplete status

3) Action Status

Shows the operating status of the AJ65SBT-CLB.

- Normal: Data links of all stations are normal.
- Data linking error: There are one or more data link error stations.
- All the station abnormality: All remote stations are abnormal.
- Remote I/O error: There are one or more remote I/O error stations.
- Station out of control range: A remote station is connected after the last refresh station.
- SW changed during operation: Any switch position was changed during operation.
- Hardware error: An error occurred during a self-loopback test (refer to Section 6.8).

(2) Monitoring Other Station

The data link statuses, etc. of the CC-Link/LT remote stations connected to the AJ65SBT-CLB are monitored.

(a) Operation procedure

Choose [Diagnostics] → [CC-Link / CC-link/LT diagnostics].

- 1) In "Module Setting" box, select "CC-Link"
- 2) In the "Module No." or "I/O Address" box, specify the master module connected with the AJ65SBT-CLB for which Monitoring Other Station will be executed.
- 3) Check the "CC-Link Bridge" check box. At this time, the station number of the AJ65SBT-CLB is searched for.
- 4) In the "Station" box, select the station number of the AJ65SBT-CLB for which Monitoring Other Station will be executed.
- 5) Click the **Start Monitoring** button.
- 6) Click the **Monitoring other station** button.

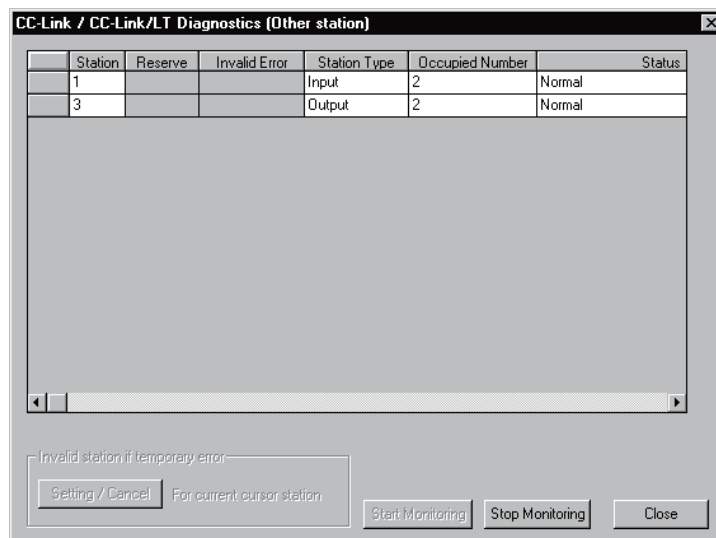

## (b) Monitor items

- 1) Station  
Shows the head station number of each station.
- 2) Station Type  
Shows the station type.  
"Input": Remote I/O station input type  
"Output": Remote I/O station output type  
"I/O": Remote I/O station input/output type  
"Device": Remote device station
- 3) Occupied Number  
Shows the number of occupied stations.
- 4) Status  
Shows the link statuses of the modules.

## (3) Loop Test

The operation statuses of the connected CC-Link/LT remote stations are checked.

A normal station is shown "blue" and an abnormal station "red".

## (a) Operation procedure

Choose [Diagnostics] → [CC-Link / CC-link/LT diagnostics].

- 1) In "Module Setting" box, select "CC-Link"
- 2) In the "Module No." or "I/O Address" box, specify the master module connected with the AJ65SBT-CLB on which Loop Test will be executed.
- 3) Check the "CC-Link Bridge" check box. At this time, the station number of the AJ65SBT-CLB is searched for.
- 4) In the "Station" box, select the station number of the AJ65SBT-CLB on which Loop Test will be executed.
- 5) Click the **Start Monitoring** button.
- 6) Click the **Loop Test** button.
- 7) Click the **Execute Test** button.

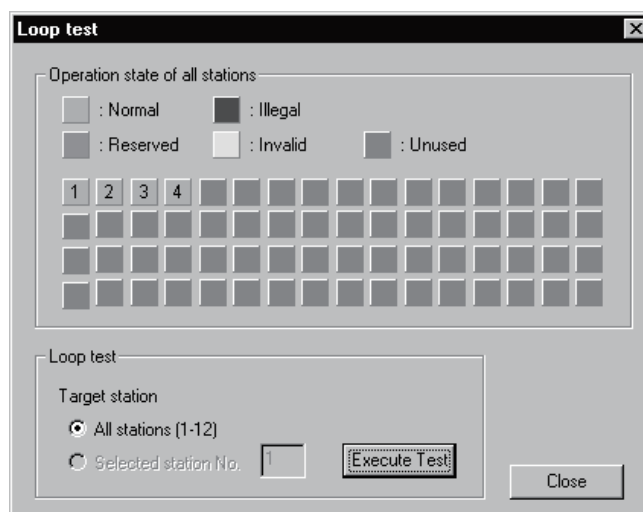

POINT
(1) In the CC-Link/LT, "Reserved" and "Invalid" stations are not displayed. (2) If the station number is duplicated, the operating status may be displayed in "white". Check the station number and the number of occupied stations for the CC-Link/LT remote station displayed in "white", and make the correct setting to eliminate the duplication.

### 6.8 Checking the Module Status (Self-loopback Test)

Check whether the individual module will operate normally or not.  
 Execute the test in the following procedure.

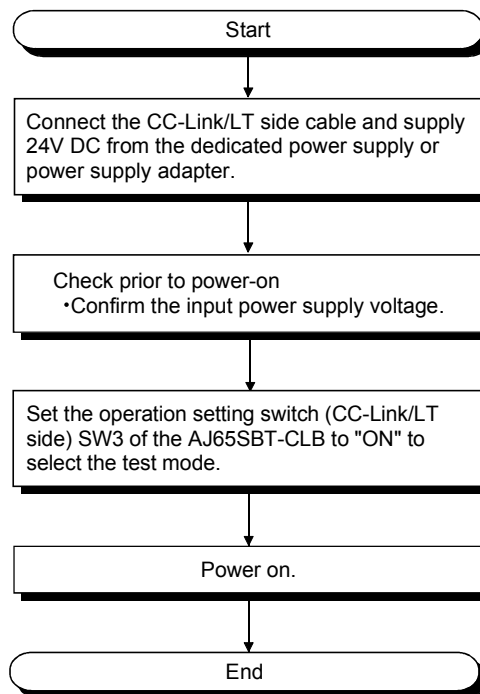

	LED Displays				Corrective Action
	PW	L RUN	L ERR.	ERR.	
When normal	On	On	Off	Off	—
When faulty	On	Off	On	Off	Change the module because of hardware fault.
	On	Off	Off	Off	
	On	Off	Off	On	Reset the operation setting switch setting.

APPENDIX

Appx 1 External Dimensions

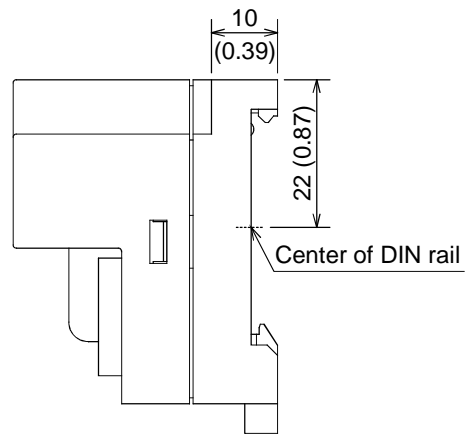
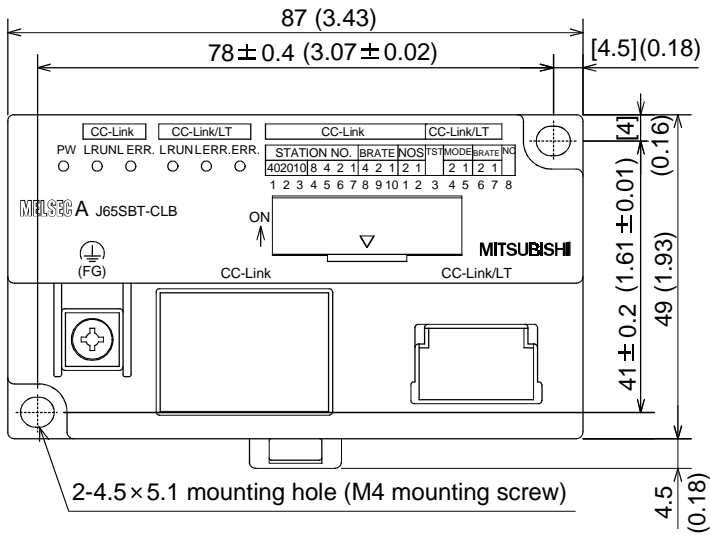
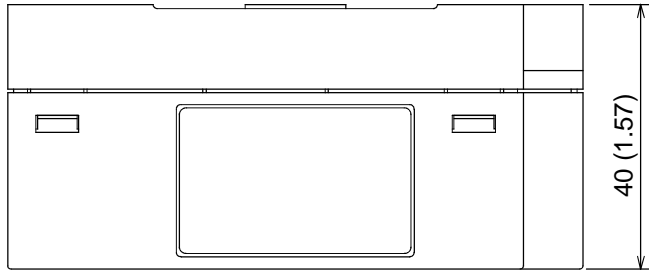

APP



Appx 2 I/O Assignment Sheet

The following is the I/O Assignment Sheet for the case that the start I/O number of the AJ65SBT-CLB is X/Y00.

Make photocopies and use them as necessary.

Appx 2.1 I/O Assignment Sheet for 4-Point Mode Setting

I/O Assignment Sheet for 4-Point Mode Setting

Station No.	Model Name	Input	Output	Station No.	Model Name	Input	Output
		X 0	Y 0			X 0	Y 0
		1	1			1	1
		2	2			2	2
		3	3			3	3
		X 4	Y 4			X 4	Y 4
		5	5			5	5
		6	6			6	6
		7	7			7	7
		X 8	Y 8			X 8	Y 8
		9	9			9	9
		A	A			A	A
		B	B			B	B
		X C	Y C			X C	Y C
		D	D			D	D
		E	E			E	E
		F	F			F	F
		X 0	Y 0			X 0	Y 0
		1	1			1	1
		2	2			2	2
		3	3			3	3
		X 4	Y 4			X 4	Y 4
		5	5			5	5
		6	6			6	6
		7	7			7	7
		X 8	Y 8			X 8	Y 8
		9	9			9	9
		A	A			A	A
		B	B			B	B
		X C	Y C			X C	Y C
		D	D			D	D
		E	E			E	E
		F	F			F	F

APP

Appx 2.2 I/O Assignment Sheet for 8-Point Mode Setting

I/O Assignment Sheet for 8-Point Mode Setting

Station No.	Model Name	Input	Output	Station No.	Model Name	Input	Output
		X 0	Y 0			X 0	Y 0
		1	1			1	1
		2	2			2	2
		3	3			3	3
		4	4			4	4
		5	5			5	5
		6	6			6	6
		7	7			7	7
		X 8	Y 8			X 8	Y 8
		9	9			9	9
		A	A			A	A
		B	B			B	B
		C	C			C	C
		D	D			D	D
		E	E			E	E
		F	F			F	F
		X 0	Y 0			X 0	Y 0
		1	1			1	1
		2	2			2	2
		3	3			3	3
		4	4			4	4
		5	5			5	5
		6	6			6	6
		7	7			7	7
		X 8	Y 8			X 8	Y 8
		9	9			9	9
		A	A			A	A
		B	B			B	B
		C	C			C	C
		D	D			D	D
		E	E			E	E
		F	F			F	F

Appx 2.3 I/O Assignment Sheet for 16-Point Mode Setting

I/O Assignment Sheet for 16-Point Mode Setting

Station No.	Model Name	Input	Output	Station No.	Model Name	Input	Output
		X	0Y			X	0Y
		1	1			1	1
		2	2			2	2
		3	3			3	3
		4	4			4	4
		5	5			5	5
		6	6			6	6
		7	7			7	7
		8	8			8	8
		9	9			9	9
		A	A			A	A
		B	B			B	B
		C	C			C	C
		D	D			D	D
		E	E			E	E
		F	F			F	F
		X	0Y			X	0Y
		1	1			1	1
		2	2			2	2
		3	3			3	3
		4	4			4	4
		5	5			5	5
		6	6			6	6
		7	7			7	7
		8	8			8	8
		9	9			9	9
		A	A			A	A
		B	B			B	B
		C	C			C	C
		D	D			D	D
		E	E			E	E
		F	F			F	F

## INDEX

- [A]  
 Applicable System..... 2- 2  
 Assignment of remote registers ..... 3-17
- [C]  
 Checking the Module Status..... 6-19  
 Connecting Modules by CC-Link/LT Side Cables  
 ..... 4- 8
- [D]  
 Data Link Processing Time..... 3-25  
 Data Link stop/restart instructions ..... 3-19  
 Data of faulty station..... 3-21  
 Data of operating statuses ..... 3-20  
 Data of remote station connection..... 3-23
- [E]  
 EMC Directive ..... A- 8  
 Error status flag clear ..... 3-19  
 External Dimension ..... App-1
- [H]  
 Handling precautions ..... 4- 3  
 How to connect dedicated flat cable connector  
 ..... 4- 9  
 How to connect high flexible cable connector  
 ..... 4-11  
 How to connect VCTF cable connector..... 4-11
- [ I ]  
 I/O signal..... 3- 5
- [L]  
 Last station number setting..... 3-19  
 Link scan time..... 3-25
- [M]  
 Mixture of different kinds of cables ..... 4-14  
 Mounting and Installation ..... 4- 3  
 Mounting terminating resistors..... 4-17
- [N]  
 Network Wiring Specifications ..... 3- 3  
 Number of occupied stations setting .... 3-14, 4- 6
- [P]  
 Part Names and Settings..... 4- 4  
 Performance Specifications..... 3- 2  
 Point mode setting switches ..... 3-14, 4- 7  
 Procedure Up to Data Link ..... 4- 1  
 Programming ..... 5- 1
- [R]  
 Remote I/O error data..... 3-22
- [S]  
 Station Status at Error Occurrence ..... 6- 1  
 System Configuration ..... 2- 1
- [T]  
 Terminating resistor ..... 4-17  
 Transmission Delay Time ..... 3-26  
 Transmission speed setting..... 4- 6  
 Troubleshooting ..... 6- 1
- [W]  
 Wiring check..... 4-22



# WARRANTY

Please confirm the following product warranty details before using this product.

## 1. Gratis Warranty Term and Gratis Warranty Range

If any faults or defects (hereinafter "Failure") found to be the responsibility of Mitsubishi occurs during use of the product within the gratis warranty term, the product shall be repaired at no cost via the sales representative or Mitsubishi Service Company.

However, if repairs are required onsite at domestic or overseas location, expenses to send an engineer will be solely at the customer's discretion. Mitsubishi shall not be held responsible for any re-commissioning, maintenance, or testing on-site that involves replacement of the failed module.

### [Gratis Warranty Term]

The gratis warranty term of the product shall be for one year after the date of purchase or delivery to a designated place.

Note that after manufacture and shipment from Mitsubishi, the maximum distribution period shall be six (6) months, and the longest gratis warranty term after manufacturing shall be eighteen (18) months. The gratis warranty term of repair parts shall not exceed the gratis warranty term before repairs.

### [Gratis Warranty Range]

- (1) The range shall be limited to normal use within the usage state, usage methods and usage environment, etc., which follow the conditions and precautions, etc., given in the instruction manual, user's manual and caution labels on the product.
- (2) Even within the gratis warranty term, repairs shall be charged for in the following cases.
  1. Failure occurring from inappropriate storage or handling, carelessness or negligence by the user. Failure caused by the user's hardware or software design.
  2. Failure caused by unapproved modifications, etc., to the product by the user.
  3. When the Mitsubishi product is assembled into a user's device, Failure that could have been avoided if functions or structures, judged as necessary in the legal safety measures the user's device is subject to or as necessary by industry standards, had been provided.
  4. Failure that could have been avoided if consumable parts (battery, backlight, fuse, etc.) designated in the instruction manual had been correctly serviced or replaced.
  5. Failure caused by external irresistible forces such as fires or abnormal voltages, and Failure caused by force majeure such as earthquakes, lightning, wind and water damage.
  6. Failure caused by reasons unpredictable by scientific technology standards at time of shipment from Mitsubishi.
  7. Any other failure found not to be the responsibility of Mitsubishi or that admitted not to be so by the user.

## 2. Onerous repair term after discontinuation of production

(1) Mitsubishi shall accept onerous product repairs for seven (7) years after production of the product is discontinued.

Discontinuation of production shall be notified with Mitsubishi Technical Bulletins, etc.

(2) Product supply (including repair parts) is not available after production is discontinued.

## 3. Overseas service

Overseas, repairs shall be accepted by Mitsubishi's local overseas FA Center. Note that the repair conditions at each FA Center may differ.

## 4. Exclusion of loss in opportunity and secondary loss from warranty liability

Regardless of the gratis warranty term, Mitsubishi shall not be liable for compensation of damages caused by any cause found not to be the responsibility of Mitsubishi, loss in opportunity, lost profits incurred to the user by Failures of Mitsubishi products, special damages and secondary damages whether foreseeable or not, compensation for accidents, and compensation for damages to products other than Mitsubishi products, replacement by the user, maintenance of on-site equipment, start-up test run and other tasks.

## 5. Changes in product specifications

The specifications given in the catalogs, manuals or technical documents are subject to change without prior notice.

## 6. Product application

- (1) In using the Mitsubishi MELSEC programmable logic controller, the usage conditions shall be that the application will not lead to a major accident even if any problem or fault should occur in the programmable logic controller device, and that backup and fail-safe functions are systematically provided outside of the device for any problem or fault.
- (2) The Mitsubishi programmable logic controller has been designed and manufactured for applications in general industries, etc. Thus, applications in which the public could be affected such as in nuclear power plants and other power plants operated by respective power companies, and applications in which a special quality assurance system is required, such as for Railway companies or Public service purposes shall be excluded from the programmable logic controller applications.

In addition, applications in which human life or property that could be greatly affected, such as in aircraft, medical applications, incineration and fuel devices, manned transportation, equipment for recreation and amusement, and safety devices, shall also be excluded from the programmable logic controller range of applications.

However, in certain cases, some applications may be possible, providing the user consults their local Mitsubishi representative outlining the special requirements of the project, and providing that all parties concerned agree to the special circumstances, solely at the users discretion.



# CC-Link - CC-Link/LT Bridge Module Type AJ65SBT-CLB

## User's Manual

MODEL	AJ65SBT-CLB-U-SY-E
MODEL CODE	13JR63
SH(NA)-080362E-F(0805)MEE	



HEAD OFFICE : TOKYO BUILDING, 2-7-3 MARUNOUCHI, CHIYODA-KU, TOKYO 100-8310, JAPAN  
NAGOYA WORKS : 1-14, YADA-MINAMI 5-CHOME, HIGASHI-KU, NAGOYA, JAPAN

When exported from Japan, this manual does not require application to the Ministry of Economy, Trade and Industry for service transaction permission.

Specifications subject to change without notice.