

MITSUBISHI PROGRAMMABLE CONTROLLERS MELSEC-F

FX3U-20SSC-H

INSTALLATION MANUAL

Manual Number	JY997D21101
Revision	D
Date	September 2007

This manual describes the part names, dimensions, and specifications of the product. Before use, read this manual and manuals of relevant products fully to acquire proficiency in handling and operating the product. Make sure to learn all the product information, safety information, and precautions. And, store this manual in a safe place so that you can take it out and read it whenever necessary. Always forward it to the end user.

Registration
The company name and the product name to be described in this manual are the registered trademarks or trademarks of each company.

Effective September, 2007
Specifications are subject to change without notice.
© 2005 Mitsubishi Electric Corporation

Safety Precaution (Read these precautions before use.)

This manual classify the safety precautions into two categories:
⚠ **DANGER** and ⚠ **CAUTION**.

DANGER	Indicates that incorrect handling may cause hazardous conditions, resulting in death or severe injury.
CAUTION	Indicates that incorrect handling may cause hazardous conditions, resulting in medium or slight personal injury or physical damage.

Depending on circumstances, procedures indicated by ⚠ **CAUTION** may also cause severe injury. It is important to follow all precautions for personal safety.

Associated Manuals

Manual name	Manual No.	Description
FX3U Series User's Manual - Hardware Edition	JY997D16501 MODEL CODE: 09R516	Explains the FX3U Series PLC specifications for I/O, wiring, installation, and maintenance.
FX3UC Series User's Manual - Hardware Edition	JY997D28701 MODEL CODE: 09R519	Explains the FX3UC Series PLC specifications for I/O, wiring, installation, and maintenance.
FX3U/FX3UC Series Programming Manual - Basic & Applied Instruction Edition	JY997D16601 MODEL CODE: 09R517	Describes PLC programming for basic/applied instructions and devices.
FX3U-20SSC-H User's Manual	JY997D21301 MODEL CODE: 09R622	Describes FX3U-20SSC-H Positioning block details.
FX Configurator-FP Operation Manual	JY997D21801 MODEL CODE: 09R916	Describes operation details of FX Configurator-FP Setting/Monitoring Tool.

How to obtain manuals
For product manuals or documents, contact with the Mitsubishi Electric dealer you purchased your product.

Certification of UL, cUL standards

The following product has UL and cUL certification.
UL, cUL File Number: E95239
Models : MELSEC FX3U series manufactured from June 1st, 2006 FX3U-20SSC-H

Compliance with EC directive (CE Marking)

This note does not guarantee that an entire mechanical module produced in accordance with the contents of this note will comply with the following standards. Compliance to EMC directive and LVD directive for the entire mechanical module should be checked by the user / manufacturer. For more details please contact the local Mitsubishi Electric sales site.

Requirement for Compliance with EMC directive

The following products have shown compliance through direct testing (of the identified standards below) and design analysis (through the creation of a technical construction file) to the European Directive for Electromagnetic Compatibility (89/336/EEC) when used as directed by the appropriate documentation.

Type: Programmable Controller (Open Type Equipment)
Models: MELSEC FX3U series manufactured from December 1st, 2005 FX3U-20SSC-H

Standard	Remark
EN61131-2:2003 Programmable controllers - Equipment requirements and tests	Compliance with all relevant aspects of the standard.
	<ul style="list-style-type: none"> • Radiated Emissions • Mains Terminal Voltage Emissions • RF immunity • Fast Transients • ESD • Conducted • Power magnetic fields

Caution for EC Directive

Attach the ferrite core to the power supply and input cables (20SSC-H side). Attach the ferrite core in approximately 200mm or less from connector on the 20SSC-H side.

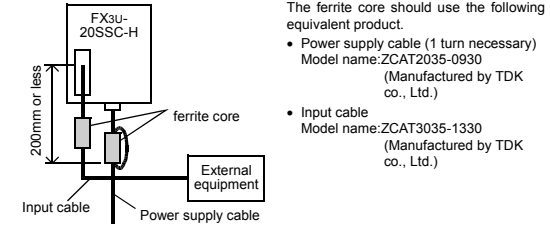

1. Introduction

FX3U-20SSC-H type positioning block (hereinafter referred to as 20SSC-H) is a special function block applicable to SSCNET III. 20SSC-H can perform positioning control by servo motor via SSCNET III applied servo amplifier.

→ For system configuration, refer to the FX3U-20SSC-H User's Manual

1.1 Major Features of the FX3U-20SSC-H

- 2-axis control is possible
One 20SSC-H controls 2 axes.
20SSC-H applies the 1-speed positioning and interrupt 1-speed constant quantity feed operations for constant quantity feed control, and also the linear interpolation and circular interpolation operations.
- Connection to servo amplifier by SSCNET III is possible
20SSC-H connects directly to the MELSERVO (our company's servo amplifier: MR-J3-B) via SSCNET III.
 - Connection using the SSCNET III cable between the 20SSC-H and the servo amplifier and between servo amplifiers reduces wiring. (Maximum length is 50m.)
 - Using the SSCNET III cable (optical communication) makes connections less susceptible to electromagnetic noise, etc. from the servo amplifier.
 - Setting the servo parameters on the 20SSC-H side and writing/reading the servo parameters to/from the servo amplifier using SSCNET III is possible.
 - Actual current values and error descriptions the servo amplifier can be checked by the buffer memories of the 20SSC-H.
- Easy application of absolute position detection system
 - The servo amplifier with absolute position detection enables the absolute positioning detection system.
 - Once the zero position is established, the zero return operation at power startup is not necessary.
 - The absolute position system allows the establishment of zero position by the data set type zero return. In this case, wiring for near-point DOG, etc. is not required.

- Easy maintenance
 - Various data such as positioning data, parameters, etc. can be saved to the flash memory (ROM) in the 20SSC-H.
 - This allows the data to be saved without a battery.
- Connectable PLC
 - The connected FX3U or FX3UC PLC reads/writes the positioning data from/to the 20SSC-H.
 - For connection to the FX3UC PLC, the FX2NC-CNV-IF or FX3UC-1PS-5V is needed.

1.2 Incorporated Items

Check that the following product and items are included in the package:

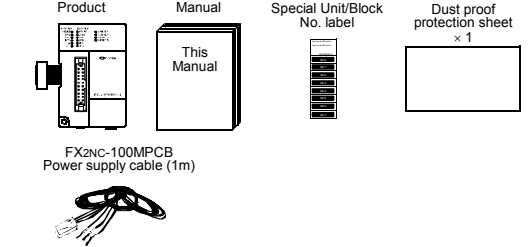

1.3 External Dimensions and Part Names

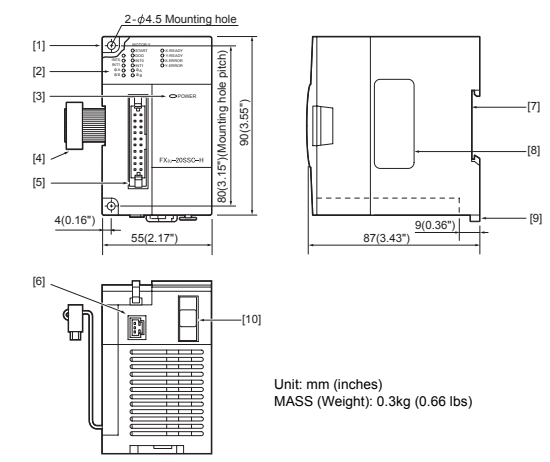

- Direct mounting hole: 2 holes of $\phi 4.5$ (0.18") (mounting screw: M4 screw)
- Status LEDs
- POWER LED (green)
- Extension cable
- Input connector
- Power supply connector
- DIN rail mounting groove (DIN rail: DIN46277)
- Name plate
- DIN rail mounting hook
- SSCNET III connector

1.4 Power and Status LED

LED display	Color	Status	Description
POWER	Green	OFF	Power is not being supplied from the external power supply or the PLC
		ON	Power is being supplied from the external power supply or the PLC
X-READY Y-READY	Green	OFF	Error is occurring or positioning is being executed on the X/Y axis
		ON	Various operation commands are acceptable on the X/Y axis

LED display	Color	Status	Description
X-ERROR Y-ERROR	Red	OFF	X/Y axis is operating normally
		Flicker	Error is occurring on the X/Y axis
		ON	CPU error is occurring on the X/Y axis
X-START Y-START	Red	OFF	START input OFF
		ON	START input ON
X-DOG Y-DOG	Red	OFF	DOG input OFF
		ON	DOG input ON
X-INT0 Y-INT0 X-INT1 Y-INT1	Red	OFF	Interrupt input OFF
		ON	Interrupt input ON
X- ϕ A Y- ϕ A	Red	OFF	Manual pulse generator A-phase input OFF
		ON	Manual pulse generator A-phase input ON
X- ϕ B Y- ϕ B	Red	OFF	Manual pulse generator B-phase input OFF
		ON	Manual pulse generator B-phase input ON

1.5 Pin Configuration

1.5.1 Input connector

For details on the input wiring and input cable, refer to the following manual.
→ Refer to the FX3U-20SSC-H User's Manual

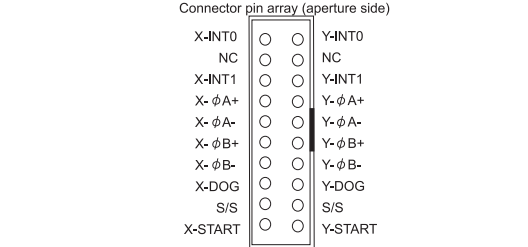

Terminal name	Description	Terminal name	Description
X-INT0	Interrupt input (for X axis)	Y-INT0	Interrupt input (for Y axis)
NC	Not used	NC	Not used
X-INT1	Interrupt input (for X axis)	Y-INT1	Interrupt input (for Y axis)
X- ϕ A+	Input terminal for A-phase input of 2-phase pulse (for X axis)	Y- ϕ A+	Input terminal for A-phase input of 2-phase pulse (for Y axis)
X- ϕ A-	Common terminal for A-phase input of 2-phase pulse (for X axis)	Y- ϕ A-	Common terminal for A-phase input of 2-phase pulse (for Y axis)
X- ϕ B+	Input terminal for B-phase input of 2-phase pulse (for X axis)	Y- ϕ B+	Input terminal for B-phase input of 2-phase pulse (for Y axis)
X- ϕ B-	Common terminal for B-phase input of 2-phase pulse (for X axis)	Y- ϕ B-	Common terminal for B-phase input of 2-phase pulse (for Y axis)
X-DOG	Near-point DOG input terminal (for X axis)	Y-DOG	Near-point DOG input terminal (for Y axis)
S/S	Power input terminal (START, DOG, INT0 and INT1) 24V DC Pins that have the same name (S/S) are shorted inside.	S/S	Power input terminal (START, DOG, INT0 and INT1) 24V DC Pins that have the same name (S/S) are shorted inside.
X-START	START input terminal (for X axis)	Y-START	START input terminal (for Y axis)

Caution

The pin array is seen from the connection side (aperture side) of the input connectors of the 20SSC-H. The pin numbers and the position of \blacktriangle vary depending on the connectors for user cables. Perform wiring properly while paying attention to the position of notches and the direction of connectors. Otherwise, the product may be damaged due to wiring mistakes.

1.5.2 Power supply connector

For the details on the power supply wiring and power cable, refer to the following manual.

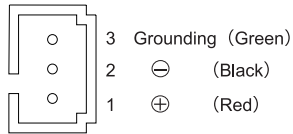

→ Refer to the FX3U-20SSC-H User's Manual

2. Specification

DESIGN PRECAUTIONS		⚠ DANGER
<ul style="list-style-type: none"> Make sure to have the following safety circuits outside of the PLC to ensure safe system operation even during external power supply problems or PLC failure. Otherwise, malfunctions may cause serious accidents. <ul style="list-style-type: none"> Most importantly, have the following: an emergency stop circuit, a protection circuit, an interlock circuit for opposite movements (such as normal vs. reverse rotation), and an interlock circuit (to prevent damage to the equipment at the upper and lower positioning limits). Note that when the PLC CPU detects an error, such as a watchdog timer error, during self-diagnosis, all outputs are turned off. Also, when an error that cannot be detected by the PLC CPU occurs in an input/output control block, output control may be disabled. External circuits and mechanisms should be designed to ensure safe machinery operation in such a case. Note that when an error occurs in a relay, triac or transistor output device, the output could be held either on or off. For output signals that may lead to serious accidents, external circuits and mechanisms should be designed to ensure safe machinery operation in such a case. 		

DESIGN PRECAUTIONS		⚠ CAUTION
<ul style="list-style-type: none"> Observe the following items. Failure to do so may cause incorrect data-writing by noise to PLCs and result the PLC failure, machine damage or an accident. <ul style="list-style-type: none"> Do not bundle the control line together with or lay it close to the main circuit or power line. As a guideline, lay the control line at least 100mm (3.94") or more away from the main circuit or power line. Noise may cause malfunctions. Ground the shield wire or shield of a shielded cable at one point on the PLC. However, do not ground at the same point as high voltage lines. Use the input, power, and optical connectors not to be pressured. Otherwise, they may be cut or cause an error. 		

STARTUP AND MAINTENANCE PRECAUTIONS		⚠ CAUTION
<ul style="list-style-type: none"> Do not disassemble or modify the unit. Doing so may cause failure, malfunction or fire. <ul style="list-style-type: none"> * For repair, contact your local Mitsubishi Electric distributor. Do not drop the product or do not exert strong impact, doing so may cause damage. 		

DISPOSAL PRECAUTIONS		⚠ CAUTION
<ul style="list-style-type: none"> Please contact a certified electronic waste disposal company for environmentally safe recycling and disposal of your device. 		

TRANSPORT AND STORAGE PRECAUTIONS		⚠ CAUTION
<ul style="list-style-type: none"> During transportation avoid any impact as the product is a precision instrument. After transportation, verify the operations of the product. 		

2.1 Applicable PLC

Model name	Applicability
FX3U Series PLC	Ver. 2.20 (from the first product) and later Up to 8 blocks can be connected
FX3UC Series PLC ¹	Ver. 2.20 (from products manufactured in May, 2005 with SER No. 55****) and later Up to 8 blocks can be connected ²

The version number can be checked by monitoring the last three digits of D8001.

¹ An FX2NC-CNV-IF or FX3UC-1PS-5V is necessary to connect the 20SSC-H with the FX3UC PLC.

² Up to 7 units can be connected to the FX3UC-32MT-LT PLC.

2.2 General Specifications

The items other than the following are equivalent to those of the PLC main unit. For general specifications, refer to the manual of the PLC main unit.

→ Refer to FX3U Series User's Manual - Hardware Edition.
→ Refer to FX3UC Series User's Manual - Hardware Edition.

Item	Specification	
Dielectric withstand voltage	500V AC for one minute	Conforming to JEM-1021
Insulation resistance	5MΩ or more by 500V DC megger	Between all terminals and ground terminal

2.3 Power Supply Specification

Item	Specification	
External power supply	Power supply voltage	24V DC +20% -15% Ripple (p-p) within 5%
	Permitted instantaneous power failure time	Operation continues when the instantaneous power failure is shorter than 5ms.
	Power consumption	5W
	Power fuse	1A
Internal power supply	PLC power supply	100mA / 5V DC

2.4 Performance Specification

Item	Specification	
Number of control axes	2 axes	
Backup	Positioning parameters, servo parameters, and table information can be saved to flash memory Write count: Maximum 100,000 times	
No. of occupied I/O points	8 points (input or output, whichever may be counted)	
Connectable servo amplifier	MELSERVO MR-J3-B Maximum 2 amplifiers can be connected Standard cord length : Station to station maximum 20m Long distance cable length: Station to station maximum 50m	
Servo bus	SSCNET III	
Scan cycle	1.77ms	
Control input	Interrupt input : 2 inputs (INT0 and INT1) per axis DOG : 1 input per input axis START input : 1 input per axis Manual pulse generator: 1 input per axis (A/B-phase)	
Parameter	Positioning parameter : 25 types Servo parameter : 50 types	
Control data	20 types	
Monitor data	31 types	
Positioning program	Created by sequence programs (using FROM/TO instruction, etc.) Direct operation (1 for X and Y axes respectively) Table operation (300 tables for X, Y, and XY axes respectively)	
Positioning	Method	Increment/Absolute
	Unit	PLS, μm, 10 ⁻⁴ inch, mdeg
	Unit magnification	1, 10, 100, and 1000-fold
	Positioning range	-2,147,483,648 to 2,147,483,647 PLS
	Speed command	Hz, cm/min, 10deg/min, inch/min
Acceleration/deceleration process	Trapezoidal acceleration/deceleration, S-pattern acceleration/deceleration: 1 to 5000ms Only trapezoidal acceleration/deceleration is available for interpolation	
Starting time	1.6ms or less	
Interpolation function	2-axes linear interpolation, 2-axes circular interpolation	

2.5 Input Specifications

2.5.1 Input specifications

Item	Specification		
Input signal name	Group 1	X axis interrupt input: X-INT0, X-INT1 Used for interrupt operation	
		Y axis interrupt input: Y-INT0, Y-INT1 Used for interrupt operation	
		X axis near-point DOG input: X-DOG Used for zero return	
		Y axis near-point DOG input: Y-DOG Used for zero return	
		START command for X axis positioning operation: X-START	
		START command for Y axis positioning operation: Y-START	
Input signal name	Group 2	Manual pulse generator input for X axis: X-φ A+/X-φ A-, X-φ B+/X-φ B- 1 edge count at 2-phase 2-count	
		Manual pulse generator input for Y axis: Y-φ A+/Y-φ A-, Y-φ B+/Y-φ B- 1 edge count at 2-phase 2-count	
		External power supply for signals: S/S Connected to power supply for INT0, INT1, DOG and START	
Input signal name	Group 1	Operation display	LED ON at input ON
		Signal voltage	24V DC +20% -15% (Power is supplied from S/S terminal)
	Input current	7.0mA± 1mA /24V DC	
	ON current	4.5mA or more	
	OFF current	1.5mA or less	
	Signal form	No-voltage contact input Sink input : NPN open collector transistor Source input : PNP open collector transistor	
	Response time	Hardware filter 1ms or less	
	Circuit insulation	Photo-coupler insulation	
	Group 2	Operation display	LED ON at input ON
		Signal voltage	3 to 5.25V DC
Input current		3.0 to 8.5mA	
ON current		3.0mA or more	
OFF current		0.5mA or less	
Signal form		Differential line driver (corresponding to AM26LS31)	
Group 3	Response frequency	2-phases pulse 100kHz or less (Duty 50%)	
	Circuit insulation	Photo-coupler insulation	
	Power supply voltage	24V DC +20% -15%	
	Consumption current	64mA or less	

2.5.2 Input Interface Internal Circuit

1) Group 1 and 3

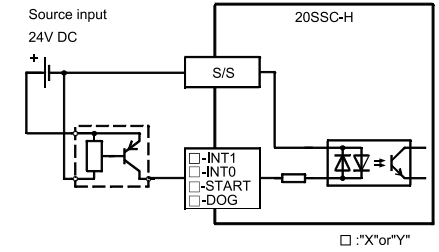
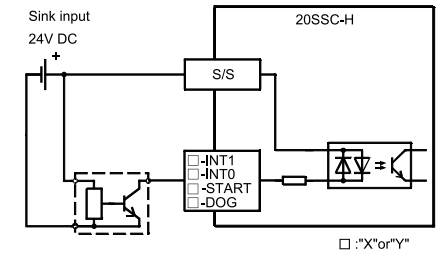

2) Group 2

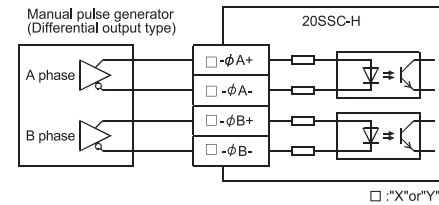

This manual confers no industrial property rights or any rights of any other kind, nor does it confer any patent licenses. Mitsubishi Electric Corporation cannot be held responsible for any problems involving industrial property rights which may occur as a result of using the contents noted in this manual.

Warranty

Mitsubishi will not be held liable for damage caused by factors found not to be the cause of Mitsubishi; opportunity loss or lost profits caused by faults in the Mitsubishi products; damage, secondary damage, accident compensation caused by special factors unpredictable by Mitsubishi; damages to products other than Mitsubishi products; and to other duties.

⚠ For safe use

- This product has been manufactured as a general-purpose part for general industries, and has not been designed or manufactured to be incorporated in a device or system used in purposes related to human life.
- Before using the product for special purposes such as nuclear power, electric power, aerospace, medicine or passenger movement vehicles, consult with Mitsubishi Electric.
- This product has been manufactured under strict quality control. However when installing the product where major accidents or losses could occur if the product fails, install appropriate backup or failsafe functions in the system.

MITSUBISHI ELECTRIC CORPORATION

HEAD OFFICE : TOKYO BUILDING, 2-7-3 MARUNOUCHI, CHIYODA-KU, TOKYO 100-8310, JAPAN
HIMEJI WORKS : 840, CHIYODA CHO, HIMEJI, JAPAN

