

*Changes for the Better*

 **mitsubishi**  
PROGRAMMABLE CONTROLLERS  
MELSEC-F

## HARDWARE MANUAL

FX<sub>2</sub>N-32DP-IF Profibus-DP Interface Unit

# FX<sub>2</sub>N



## Foreword

- This manual contains text, diagrams and explanations which will guide the reader in the correct installation and operation of the FX2N-32DP-IF Profibus-DP Interface Unit. It should be read and understood before attempting to install or use the unit.
- For operation and setting of FX2N-32DP-IF Profibus-DP Interface Unit, refer to FX2N-32DP-IF User's Manual. Further information can be found in the FX2N Series Hardware Manual, manuals for special function blocks and Profibus-DP master programmable controllers.
- If in doubt at any stage during the installation of the FX2N-32DP-IF Profibus-DP Interface Unit always consult a professional electrical engineer who is qualified and trained to the local and national standards.
- If in doubt about operation or use of the FX2N-32DP-IF Profibus-DP Interface Unit please consult the nearest Mitsubishi Electric distributor.
- This manual is subject to change without notice.



# **FX<sub>2</sub>N-32DP-IF Profibus-DP Interface Unit**

## **Hardware Manual**

Manual number : JY992D77101

Manual revision : E

Date : November 2008



## **Guidelines for the Safety of the User and Protection of the FX<sub>2N</sub>-32DP-IF Profibus-DP Interface Unit.**

This manual provides information for the use of the FX<sub>2N</sub>-32DP-IF Profibus-DP Interface Unit. The manual has been written to be used by trained and competent personnel. The definition of such a person or persons is as follows:

- a) Any engineer who is responsible for the planning, design and construction of automatic equipment using the product associated with this manual, should be of a competent nature, trained and qualified to the local and national standards required to fulfill that role. These engineers should be fully aware of all aspects of safety with regards to automated equipment.
- b) Any commissioning or service engineer must be of a competent nature, trained and qualified to the local and national standards required to fulfill that job. These engineers should also be trained in the use and maintenance of the completed product. This includes being completely familiar with all associated documentation for said product. All maintenance should be carried out in accordance with established safety practices.
- c) All operators of the completed equipment should be trained to use that product in a safe and coordinated manner in compliance to established safety practices. The operators should also be familiar with documentation which is connected with the actual operation of the completed equipment.

**Note :** The term ‘completed equipment’ refers to a third party constructed device which contains or uses the product associated with this manual.

## Note's on the Symbols Used in this Manual

At various times through out this manual certain symbols will be used to highlight points of information which are intended to ensure the users personal safety and protect the integrity of the equipment. Whenever any of the following symbols are encountered its associated note must be read and understood. Each of the symbols used will now be listed with a brief description of its meaning.

### Hardware Warnings



1) Indicates that the identified danger **WILL** cause physical and property damage.



2) Indicates that the identified danger could **POSSIBLY** cause physical and property damage.



3) Indicates a point of further interest or further explanation.

### Software Warnings



4) Indicates special care must be taken when using this element of software.



5) Indicates a special point which the user of the associate software element should be aware.



6) Indicates a point of interest or further explanation.

- Under no circumstances will Mitsubishi Electric be liable responsible for any consequential damage that may arise as a result of the installation or use of this equipment.
- All examples and diagrams shown in this manual are intended only as an aid to understanding the text, not to guarantee operation. Mitsubishi Electric will accept no responsibility for actual use of the product based on these illustrative examples.
- Please contact a Mitsubishi distributor for more information concerning applications in life critical situations or high reliability.





# Table of Contents

Safety Guidelines .....	iii
1. Introduction.....	1-1
1.1 Features of the 32DP-IF .....	1-1
1.2 External Dimensions and Each Part Name .....	1-2
1.2.1 Pin Configuration .....	1-4
1.3 System Configuration .....	1-5
1.3.1 Connected Monitoring Tools .....	1-6
1.3.2 Connected Extension Blocks and Units .....	1-7
1.3.3 Configuration Rules Reference .....	1-8
2. Mounting and Wiring .....	2-1
2.1 Mounting.....	2-1
2.1.1 Mounting Arrangements .....	2-1
2.1.2 Mounting.....	2-3
2.2 Caution for Wiring.....	2-5
2.3 Power Supply .....	2-9
2.3.1 AC Power Supply Type: FX2N-32DP-IF .....	2-10
2.3.2 DC Power Supply Type: FX2N-32DP-IF-D .....	2-12
2.4 Profibus-DP Network.....	2-14
2.5 Wiring for Connecting to Extension Blocks/Units and Special Function Blocks	2-16

3. Specifications .....	3-1
3.1 General Specifications.....	3-1
3.2 Power Supply Specifications .....	3-2
3.3 Performance Specifications.....	3-3
4. Address Setting .....	4-1
4.1 Setting the Address .....	4-1
4.2 Example Address Setting .....	4-2
5. Diagnostics .....	5-1
5.1 Preliminary Checks.....	5-1
5.2 Check the Status of the LEDs of the 32DP-IF .....	5-2
Appendix A	
Further Information Manual Lists.....	A-1
Appendix B	
Update History of FX2N-32DP-IF and GSD File .....	B-1

# 1. Introduction

The FX<sub>2N</sub>-32DP-IF(-D) Profibus-DP Interface Unit (called “32DP-IF” hereinafter) can be used to connect FX<sub>2N</sub>/FX<sub>0N</sub> series extension units/blocks and special function units/blocks directly to an existing Profibus-DP network.

The 32DP-IF provides an intelligent slave function for decentralized control applications. Digital and analog data from a Profibus-DP master CPU (called “DP-master” hereinafter) can be sent and received to/from any of the supported I/O blocks and special function blocks.

## 1.1 Features of the 32DP-IF

Using the 32DP-IF the FX<sub>2N</sub>/FX<sub>0N</sub> series extension units/blocks and special function units/blocks can exchange data with any DP-master.

- Up to 256 I/O points and/or up to 8 special function blocks can be connected to the 32DP-IF. However, adjust total control I/O points to 256 or less. See section 1.3.
- The slave address of the 32DP-IF is adjusted by DIP switches. See chapter 4.
- The 32DP-IF can be connected to a Profibus-DP network via a standard 9-pin D-SUB connector and a shielded twisted pair cable complying with EN50170. Optional glassfiber adapters are supported by the 32DP-IF and are available from other vendors. See chapter 2.
- An FX-20P-E or personal computer can be used to monitor the status of the 32DP-IF and the data exchanged with the Profibus network. For operating instructions of the FX-20P-E or personal computer, refer to their respective operation manuals. For device numbers and explanation, refer to the FX<sub>2N</sub>-32DP-IF User’s Manual.

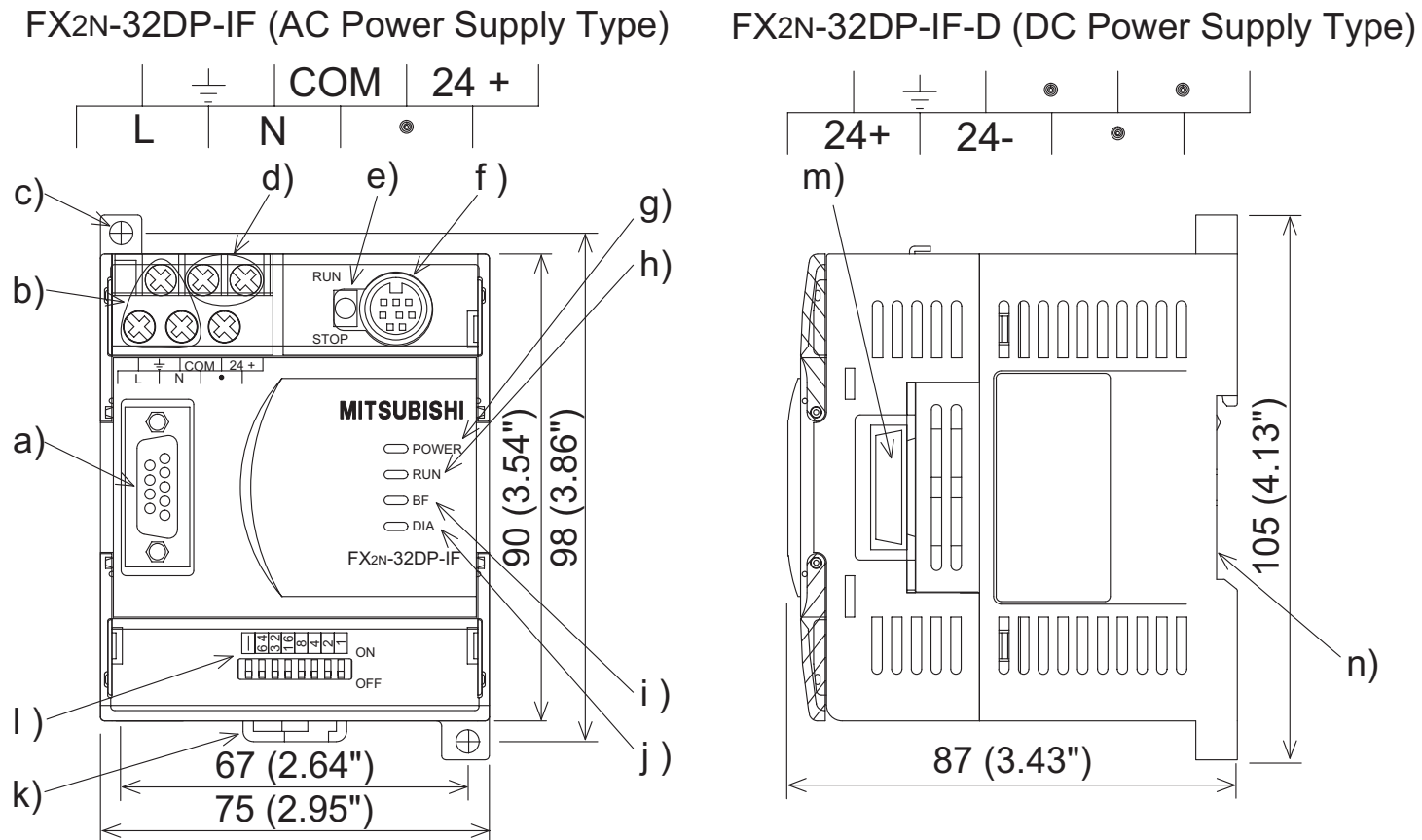
## 1.2 External Dimensions and Each Part Name

Dimensions: mm (inches)

Accessory: GSD files (FD: 1 piece)

MASS (Weight): Approx. 0.4 kg (0.88 lbs)

**Figure 1.1: External Dimensions**

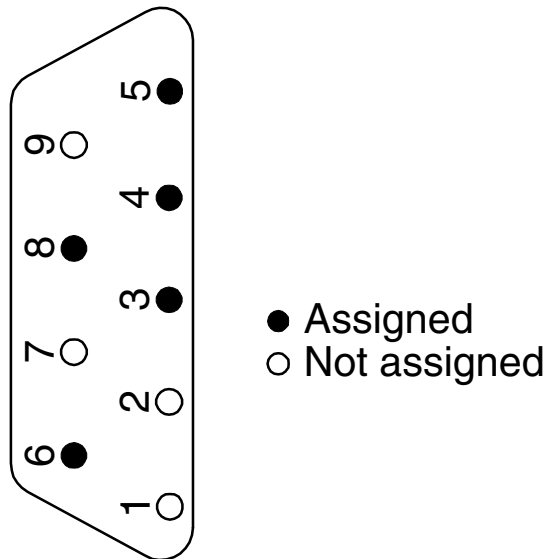


- a) Profibus-DP communication port (D-SUB 9 pin)
- b) Power supply terminals (screw terminal: M3.5 (0.14"))
  - FX<sub>2</sub>N-32DP-IF (AC power supply type): L, N and grounding terminal
  - FX<sub>2</sub>N-32DP-IF-D (DC power supply type): 24+, 24- and grounding terminal
- c) Direct mounting hole (2-φ4.5 (0.18"))
- d) 24 V DC power terminal (screw terminal: M3.5 (0.14"))
  - FX<sub>2</sub>N-32DP-IF-D does not have this terminal.
- e) RUN/STOP switch: When this switch is in the RUN position, the 32DP-IF will exchange data with extension units/blocks and special function blocks. If this switch is in the STOP position, the 32DP-IF will exchange only input data with extension units/blocks.
- f) Communication port for FX-20P-E or personal computer
- g) POWER LED: ON when power is supplied.
- h) RUN LED: ON when 32DP-IF is exchanging data with extension units/blocks and special function blocks.
- i) BF LED: ON when a communication error is detected (No data exchange).
- j) DIA LED: ON when diagnostic data is detected.
- k) Hook for DIN rail mounting
- l) DIP switches for slave address of this unit
- m) Extension port
- n) Groove for DIN rail mounting (DIN rail width: 35 mm (1.38"))

### 1.2.1 Pin Configuration

The connector is a 9-pin D-SUB type and the pin configuration is shown below.

**Figure 1.2: Pin Layout 9-pin D-SUB**

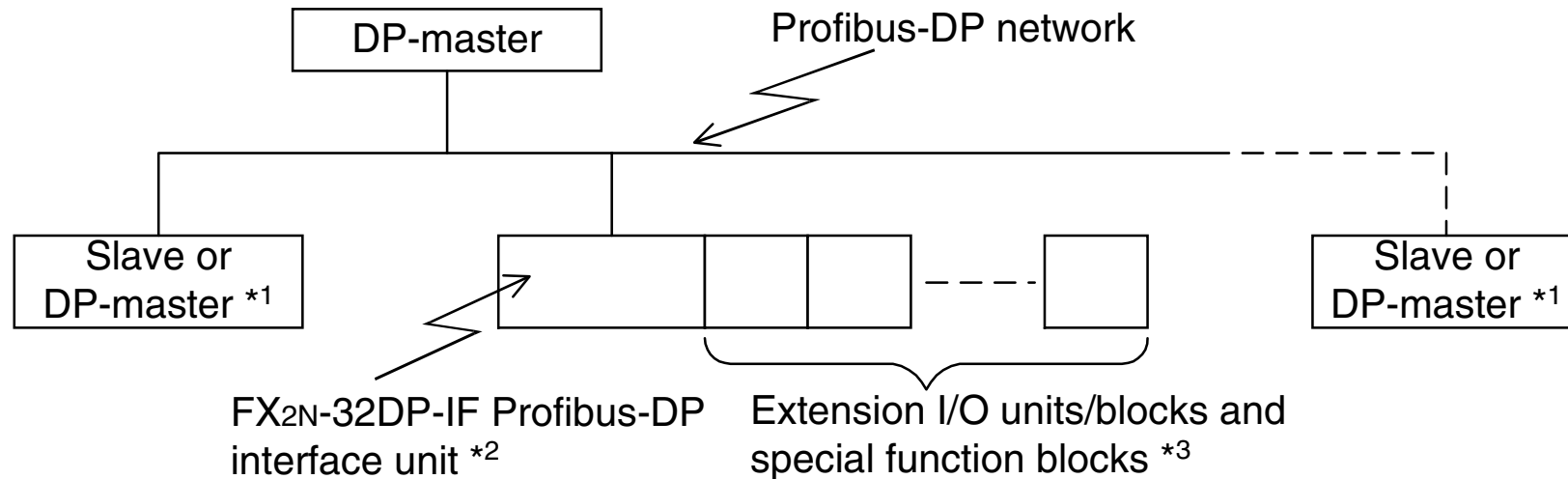


**Table 1.1: Pin Configuration**

Connector	Signal	Meaning
3	RXD/TXD-P	Receive/transmit-Data-P
4	RTS	Request to send
5	DGND	Data Ground
6	VP	Voltage-Plus
8	RXD/TXD-N	Receive/transmit-Data-N
1,2,7,9	NC	Pin not assigned

## 1.3 System Configuration

**Figure 1.3: System Configuration**



\*1 The units at each end of the Profibus-DP network must have a terminating resistor. This will either be in the master, slave unit or in the Profibus connector.

\*2 For connecting a monitoring tool, refer to subsection 1.3.1

\*3 For connecting units/blocks, refer to subsection 1.3.2.



### Caution

The parameter data of the 32DP-IF must be set correctly in the DP-master, if the parameter data is not correct, the operation of the module may be affected.

For parameter of 32DP-IF, refer to FX2N-32DP-IF User's Manual.

### 1.3.1 Connected Monitoring Tools

An FX-20P-E or personal computer can be used to monitor the 32DP-IF and the data exchanged with the Profibus. For operating instructions of the FX-20P-E or personal computer, refer to their respective operation manuals. For device numbers and explanation, refer to the FX<sub>2N</sub>-32DP-IF User's Manual.

Connecting cable is same as FX<sub>2N</sub> MPU.

**Table 1.2: Connected Programming Tools**

Monitoring Tools	Description
FX-20P-E	Device monitor
Personal Computer (MELSEC MEDOC PLUS)	



#### Note;

For monitoring the 32DP-IF with a personal computer the PLC setting must be adjusted as for the FX series PLC type.



### 1.3.2 Connected Extension Blocks and Units

**Table 1.3: Extension I/O Blocks/Units and Special Function Blocks**

Unit Type		Supported Version	Type Name
Extension Units (Digital I/O Units)		Model: V1.00 ~ GSD file:V1.00 ~	FX <sub>2N</sub> -32ER-ES/UL, FX <sub>2N</sub> -32ET-ESS/UL, FX <sub>2N</sub> -48ER-ES/UL, FX <sub>2N</sub> -48ET-ESS/UL FX <sub>2N</sub> -48ER-UA1/UL
		Model: V2.10 ~ GSD file:V2.10 ~	FX <sub>2N</sub> -48ER-DS, FX <sub>2N</sub> -48ET-DSS
Extension Blocks (Digital I/O Blocks)	FX <sub>2N</sub> Series	Model: V1.00 ~ GSD file:V1.00 ~	FX <sub>2N</sub> -16EX-ES/UL, FX <sub>2N</sub> -16EYR-ES/UL, FX <sub>2N</sub> -16EYT-ESS/UL
	FX <sub>0N</sub> Series	Model: V1.00 ~ GSD file:V1.00 ~	FX <sub>0N</sub> -8EX-UA1/UL, FX <sub>0N</sub> -8EX-ES/UL, FX <sub>0N</sub> -16EX-ES/UL, FX <sub>0N</sub> -8ER-ES/UL, FX <sub>0N</sub> -8EYR-ES/UL, FX <sub>0N</sub> -8EYT-ESS/UL, FX <sub>0N</sub> -16EYR-ES/UL, FX <sub>0N</sub> -16EYT-ESS/UL
Special Function Blocks/Units		Model: V1.00 ~ GSD file:V1.00 ~	FX <sub>2N</sub> -4DA, FX <sub>2N</sub> -4AD, FX <sub>2N</sub> -4AD-PT, FX <sub>2N</sub> -4AD-TC
		Model: V1.10 ~ GSD file:V1.10 ~	FX <sub>2N</sub> -2DA, FX <sub>2N</sub> -2AD, FX <sub>0N</sub> -3A, FX <sub>2N</sub> -1HC, FX <sub>2N</sub> -1PG, FX <sub>2N</sub> -10GM, FX <sub>2N</sub> -20GM, FX <sub>2N</sub> -32ASI-M, FX <sub>2N</sub> -232IF
		Model: V2.10 ~ GSD file:V2.10 ~	FX <sub>2N</sub> -8AD, FX <sub>2N</sub> -2LC, FX <sub>2N</sub> -10PG

### 1.3.3 Configuration Rules Reference

Further information for the Configuration Rules can be found in FX<sub>2N</sub>-32DP-IF User's Manual.

1) Total I/O points on the system  $\leq 256$  points

The following (a ~ c) I/O points must be a total of 256 points or less.

For I/O point allocation for each extension unit/block and each special function unit/block, refer to FX<sub>2N</sub>-32DP-IF User's Manual.

a) Count I/O points for the extension units/blocks (including additional occupied points).

b) Count the occupation I/O points for special function units/blocks.

A 32DP-IF can connect a Maximum of 8 special function blocks.

c) Count I/O points for FX<sub>2N</sub>-32ASI-M's active slaves.

2) Supply 24V DC (total internal and service power supply) and 5V DC to the extension I/O blocks and special function units/blocks from the 32DP-IF or extension I/O units.

If 24V DC and 5V DC is not supplied to both special function blocks and extension I/O blocks, the hardware configuration will need to be changed.

For power consumption, refer to FX<sub>2N</sub>-32DP-IF User's Manual.

3) Total exchange data length  $\leq 200$  bytes

(or DP master's maximum exchange data length if  $\leq 200$  bytes)

The following (a, b) exchange data must be a total of 200 bytes (or DP master's maximum exchange data length if  $\leq 200$  bytes) or less.

For exchange data length, refer to FX<sub>2N</sub>-32DP-IF User's Manual.

a) Total exchange data for extension I/O units/blocks.

b) Total exchange data for special function units/blocks.

- 4) Total user parameter length  $\leq 193$  bytes  
(or DP master's maximum user parameter length if  $\leq 193$  bytes)  
The user parameter length must be a total of 193 bytes (or DP master's maximum exchange data length if  $\leq 193$  bytes) or less.  
For user parameter length, refer to FX2N-32DP-IF User's Manual.

# MEMO

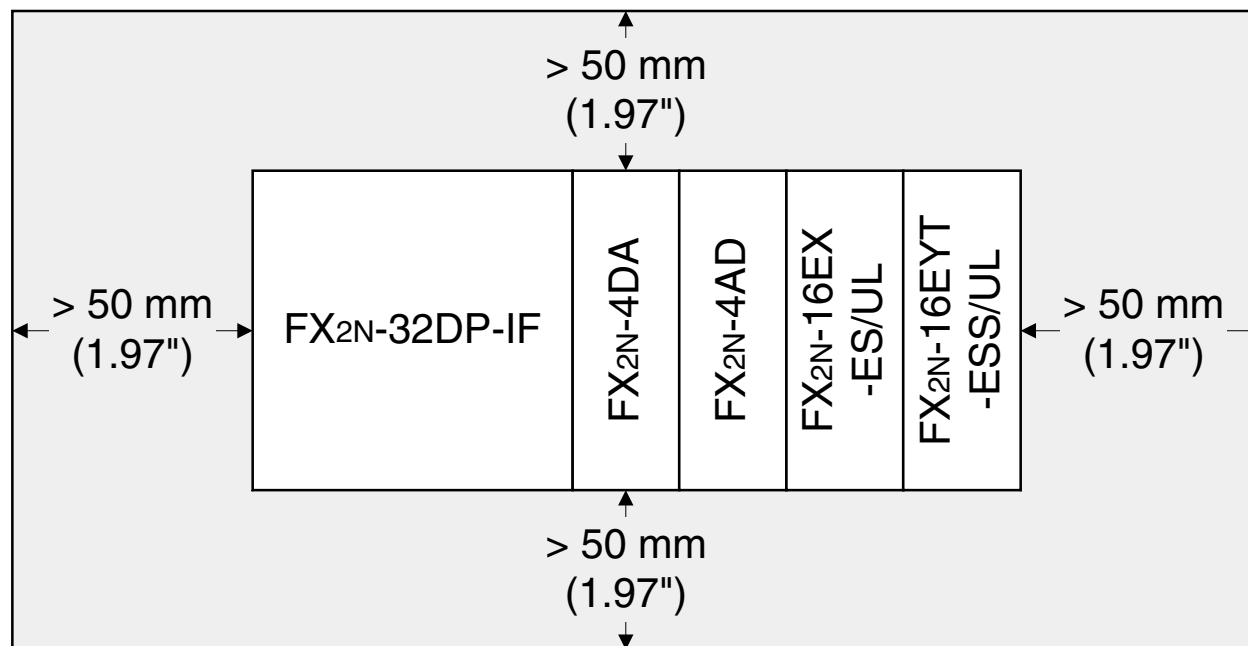
## 2. Mounting and Wiring

### 2.1 Mounting

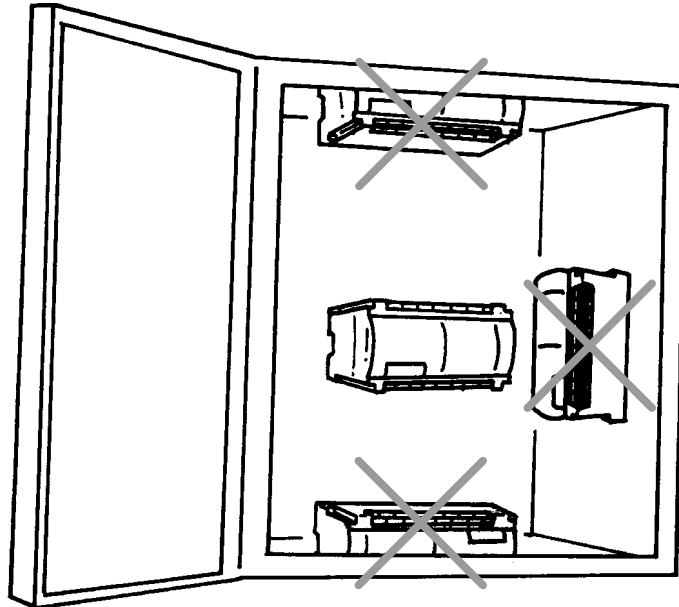
#### 2.1.1 Mounting Arrangements

To prevent a rise in temperature, mount the units to the back walls. Never mount them to the floor, ceiling or side wall of an enclosure.

**Figure 2.1: Mounting Location**



**Figure 2.2: Mounting Arrangement**



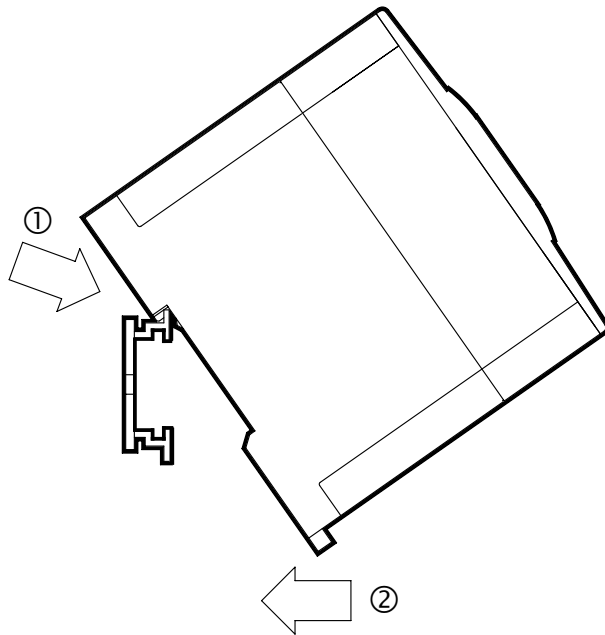
## 2.1.2 Mounting

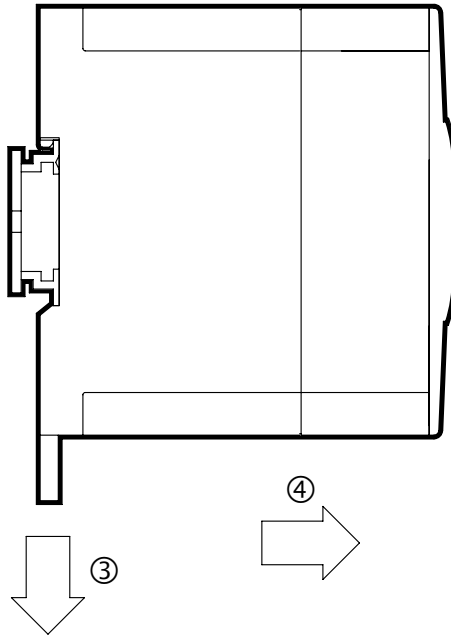
Mounting method for the 32DP-IF is DIN rail mounting or direct wall mounting.

### 1) DIN Rail Mounting

- Align the upper side of the DIN rail mounting groove of the 32DP-IF with a DIN rail\*1 (①), and push it on the DIN rail(②). See Figure 2.3.
- When removing the 32DP-IF from the DIN rail, the hook for DIN rail is pulled (③), and the 32DP-IF is removed (④). See Figure 2.4.

**Figure 2.3: Attach to DIN Rail**



**Figure 2.4: Remove from DIN Rail**

\*1 Uses DIN 46277 <35mm (1.38")>

## 2) Direct Mounting to Back Walls

The 32DP-IF can be mounted with M4 screws by using the direct mounting holes.

An interval space between each unit of 1 ~ 2 mm is necessary.

For mounting hole position of 32DP-IF, refer to section 1.2. Further information about extension I/O units/blocks can be found in the FX<sub>2N</sub> Hardware Manual. Further information about special function units/blocks can be found in each manual.



## 2.2 Caution for Wiring



- 1) Do not lay signal cable near to either high voltage power cabling or cabinet housing along the same trunking duct. Effects of noise or surge induction may occur. Keep signal cables of more than 100 mm (3.94") from these power cables.
- 2) Ground the shield wire or the shield of a cable at one point on the module. Do not, however, ground at the same point as high voltage lines.
- 3) Cut off all phases of power source before installation or performing wiring work in order to avoid electric shock or damage to the product.
- 4) Replace the provided terminal cover before supplying power and operating the unit after installation or wiring work, in order to avoid electric shock.
- 5) To connect the 32DP-IF to a Profibus-DP network should be used only the Profibus connectors and shielded twisted-pair cable complying with EN50170.
- 6) The power supply of the extension units/blocks and the special function units/blocks should be starting-up at the same time or earlier than it with 32DP-IF.
- 7) DO NOT use the “●” terminal of the 32DP-IF.
- 8) “24+” and “24-” terminal are not reversible.  
If “24+” and “24-” terminal are reversed, the units/block may be serious damaged.

- 9) The terminal tightening torque is 0.5 to 0.8 N•m. Tighten securely to avoid malfunction.
- 10) The terminal screws of FX<sub>2N</sub>-32DP-IF is M3.5 (0.14"). However, the terminal screws of the FX<sub>0N</sub>, FX<sub>2N</sub> Series extension I/O units/blocks and special function units/blocks are M3 (0.12"). The crimp style terminal (see drawing) suitable for use with these screws should be fitted to the cable for wiring.
- When installing 1 or 2 crimp terminal to a terminal, see each explanation below. However, 3 crimp terminals or more cannot be installed to a single terminal.

- a) Handle the crimp terminal of the following size as and when 1 wire is used per terminal. Refer to Figure 3.3 for installation instructions.

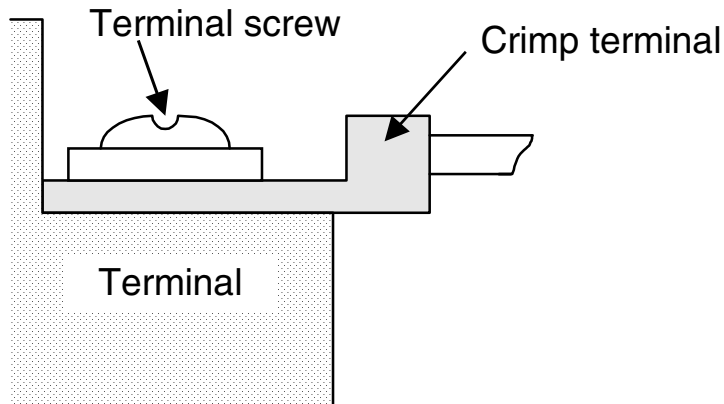
**Figure 2.5: Crimp Terminal for M3.5 Screws**



**Figure 2.6: Crimp Terminal for M3 Screws**

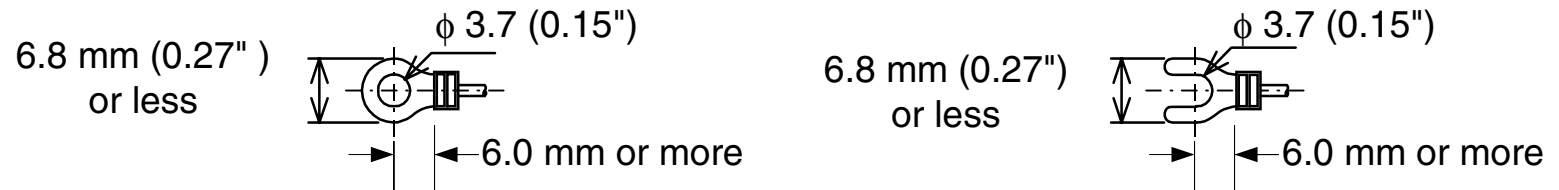


**Figure 2.7: Installing 1 wire Per Terminal**

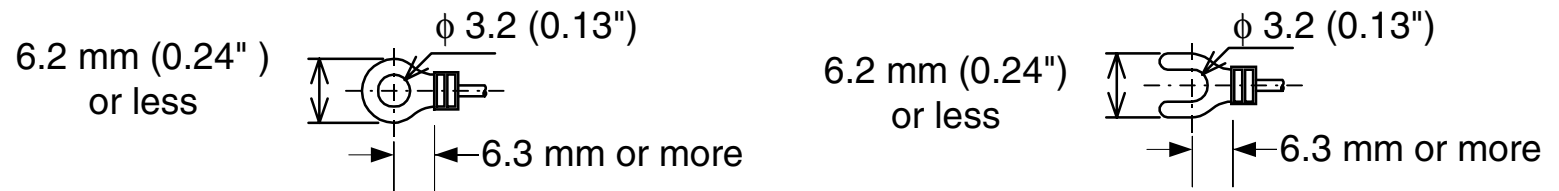


- b) Handle the crimp terminal of the following size as and when 2 wires are used per terminal. Refer to Figure 3.6 for installation instructions.

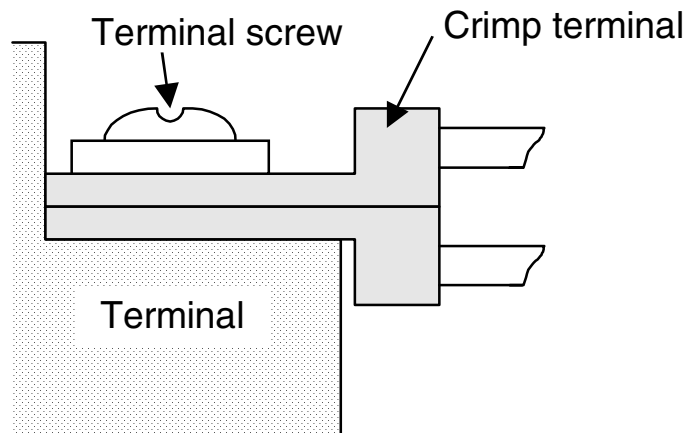
**Figure 2.8: Crimp Terminal for M3.5 Screws**



**Figure 2.9: Crimp Terminal for M3 Screws**



**Figure 2.10: Installing 2 Wires Per Terminal**



## **2.3 Power Supply**

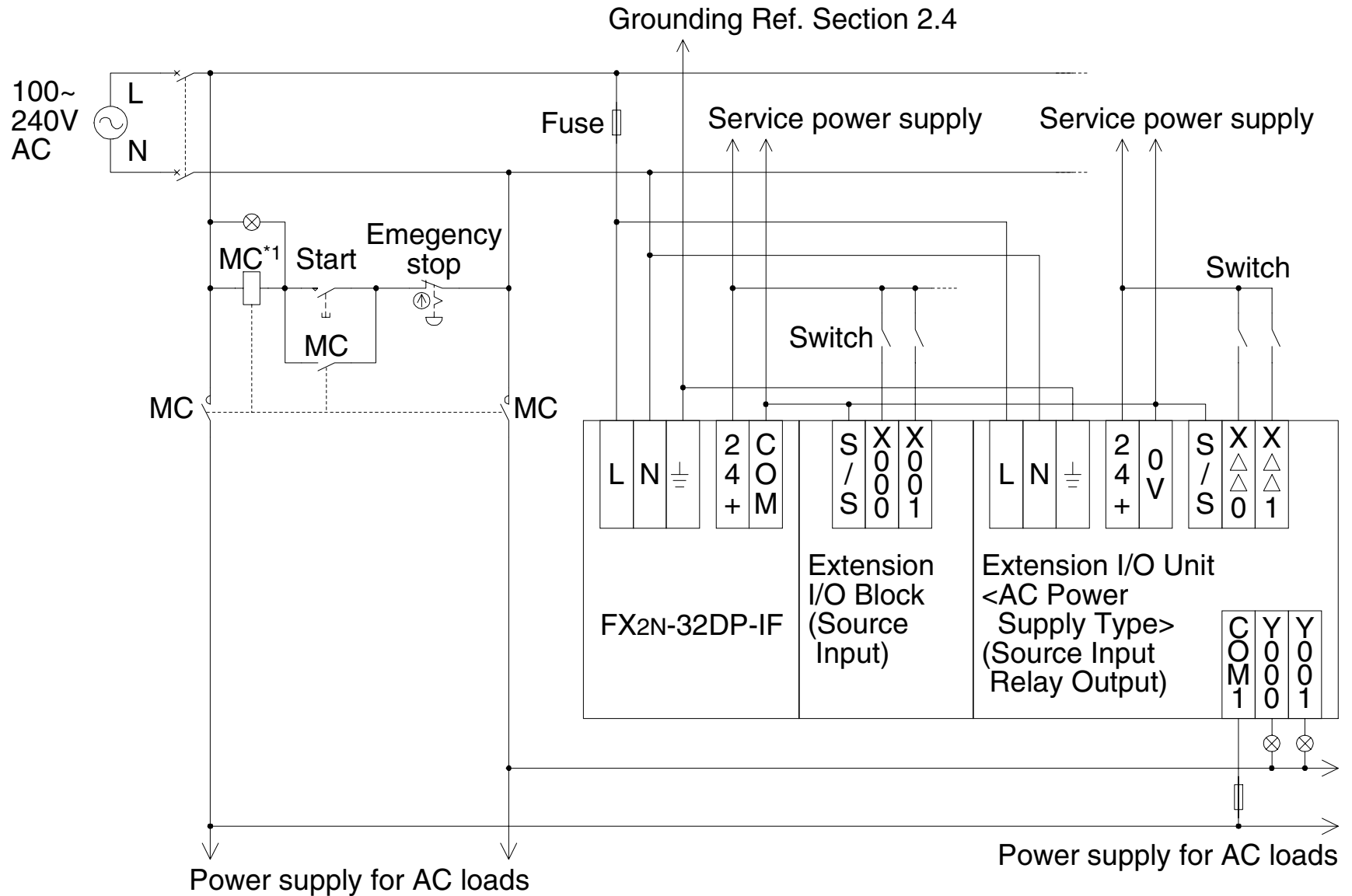
Further information for the extension unit's wiring can be found in the FX<sub>2N</sub> Series Hardware Manual. Further information for special function units/blocks can be found in their respective manual. For wiring of grounding, refer to Section 2.4.

### 2.3.1 AC Power Supply Type: FX<sub>2N</sub>-32DP-IF

When wiring a 32DP-IF and extension I/O units/blocks, the connection method is identical to a FX<sub>2N</sub> series PLC. Further information can be found in the FX<sub>2N</sub>-32DP-IF User's Manual and FX<sub>2N</sub> Series Hardware Manual.

- Supply both FX<sub>2N</sub>-32DP-IF and extension I/O units from the same AC power source.
- Connect "COM" terminal on the 32DP-IF to the "0V" terminal on the extension unit.
- For ground wiring, refer to Section 2.4.

Figure 2.11: AC Power Supply Type: FX2N-32DP-IF



\*1 Magnetic contact safety circuit

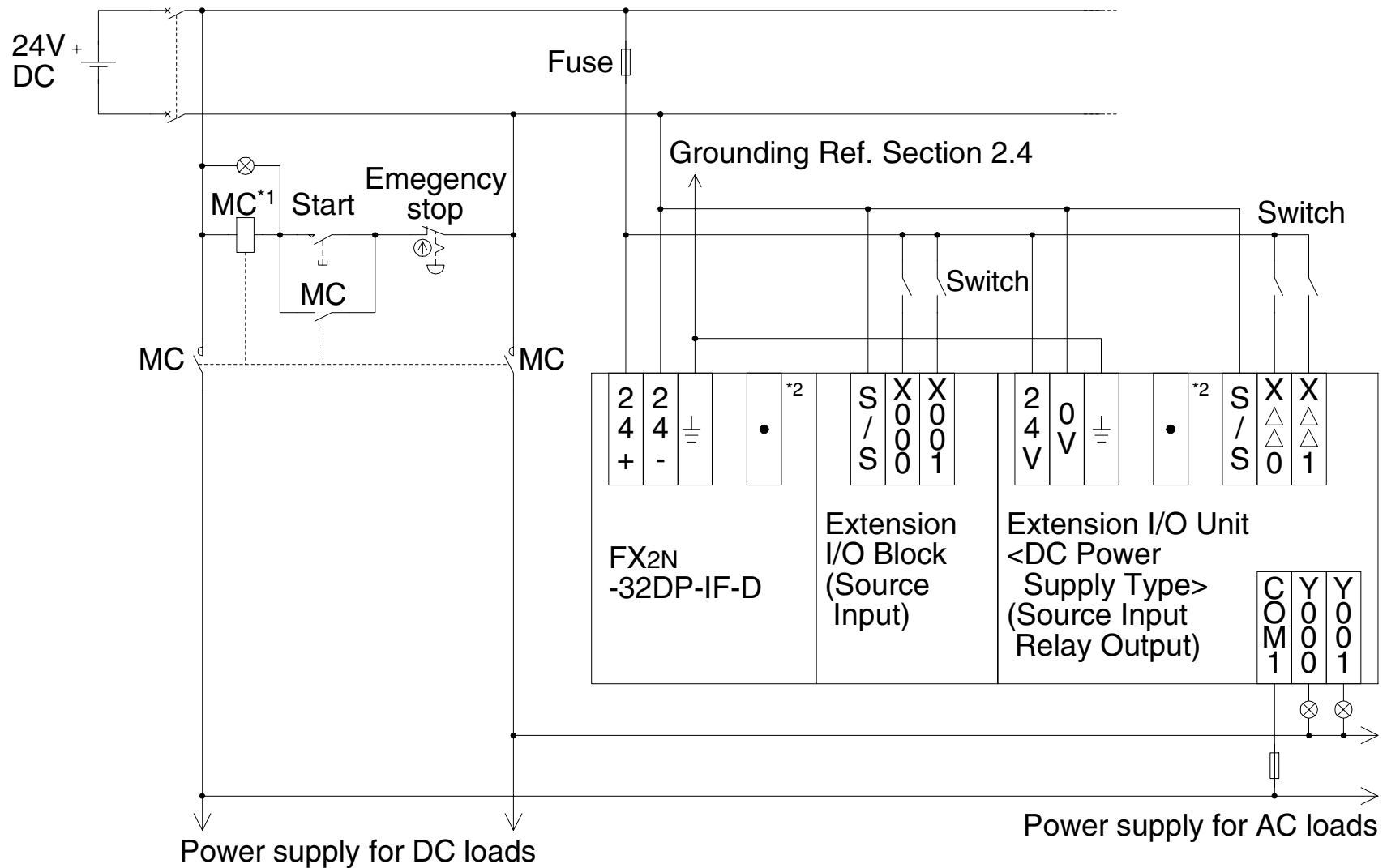
### 2.3.2 DC Power Supply Type: FX<sub>2N</sub>-32DP-IF-D

When wiring a 32DP-IF and extension I/O units/blocks, the connection method is identical to a FX<sub>2N</sub> series PLC. Further information can be found in the FX<sub>2N</sub>-32DP-IF User's Manual and FX<sub>2N</sub> Series Hardware Manual.

- Supply both FX<sub>2N</sub>-32DP-IF-D and extension I/O units/blocks from the same DC power source.
- For ground wiring, refer to Section 2.4.



Figure 2.12:DC Power Supply Type: FX2N-32DP-IF-D



\*1 Magnetic contact safety circuit  
 \*2 DO NOT connect wire to this terminal.

## 2.4 Profibus-DP Network

To connect the 32DP-IF to a Profibus-DP network should be used only the Profibus connectors and shielded twisted-pair cable complying with EN50170.

Please use terminating resistors and Profibus connectors as shown in the DP-master manual and Profibus connector manual.

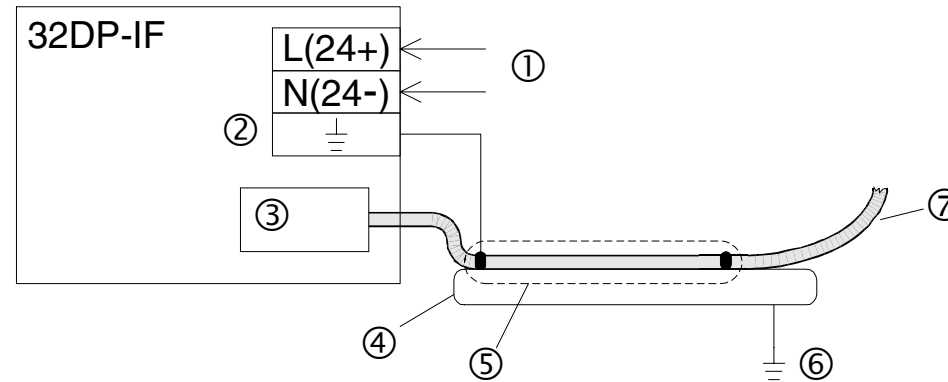
The 32DP-IF does not have a terminating resistance built-in.



### Note: Noise Prevention

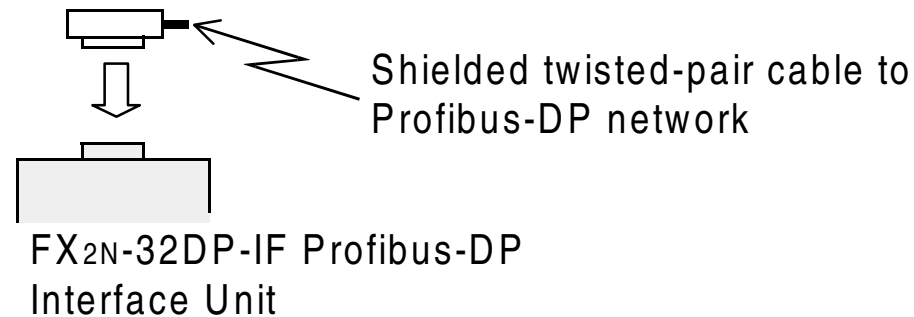
For noise prevention please attach at least 50mm (1.97") of the shielded twisted-pair cable along the grounding plate to which the ground terminal is connected.

**Figure 2.13: Connect to Profibus-DP Network**



**Table 2.1: Connect to Profibus-DP Network**

Ref.	Description
①	Power source for 32DP-IF (Refer to section 3.2)
②	Grounding terminal in 32DP-IF
③	Profibus connector (Refer to Figure 3.10)
④	Grounding plate
⑤	For noise Prevention please attach at least 50mm (1.97") of the shielded twisted-pair cable along the grounding plate to which the ground terminal is connected.
⑥	Grounding resistance of 100Ω or less
⑦	Shielded twisted-pair cable complying with EN50170 to Profibus-DP network

**Figure 2.14: Profibus Connection**

## 2.5 Wiring for Connecting to Extension Blocks/Units and Special Function Blocks

Further information can be found in FX<sub>2N</sub>-32DP-IF User's Manual, FX<sub>2N</sub> Hardware Manual and each manual for using special function unit/block.

### 1) AC Power Supply Type (FX<sub>2N</sub>-32DP-IF)

- a) Supply both FX<sub>2N</sub>-32DP-IF and extension I/O units from the same AC power source.
- b) Connect "COM" terminal on the FX<sub>2N</sub>-32DP-IF to the "0V" terminal on the extension units. For extension unit's wiring, refer to FX<sub>2N</sub> Series Hardware Manual.

### 2) DC Power Supply Type FX<sub>2N</sub>-32DP-IF-D)

Supply both FX<sub>2N</sub>-32DP-IF-D and extension I/O units/blocks from the same DC power source.

### 3. Specifications

#### 3.1 General Specifications

**Table 3.1: General Specifications**

Item		Description
Operating Temperature		0 ~ 55°C (32 to 131°F)
Storage Temperature		-20 ~ 70°C (-4 to 158°F)
Operating Humidity		35 ~ 85% Relative Humidity, No condensation
Storage Humidity		35 ~ 90% Relative Humidity, No condensation
Vibration Resistance - Direct Mounting		10 ~ 57Hz: 0.075mm Half Amplitude 57 ~ 150Hz: 9.8m/s <sup>2</sup> Acceleration Sweep Count for X, Y, Z: 10 times (80 min in each direction)
Vibration Resistance - DIN rail Mounting		10 ~ 57Hz: 0.035mm Half Amplitude 57 ~ 150Hz: 4.9m/s <sup>2</sup> Acceleration Sweep Count for X, Y, Z: 10 times (80min in each direction)
Shock Resistance		147m/s <sup>2</sup> Acceleration, Action Time: 11ms 3 times in each direction X, Y, and Z
Noise Immunity		1,000Vp-p, 1microsecond, 30 ~ 100Hz, tested by noise simulator
Dielectric Withstand Voltage	FX2N-32DP-IF	1,500V AC > 1 min, tested between all points, terminals and ground
	FX2N-32DP-IF-D	500V AC > 1 min, tested between all points, terminals and ground
Insulation Resistance		5MΩ > at 500V DC, tested between all points, terminals and ground
Grounding		Grounding resistance is 100Ω or less
Complies with		UL508

## 3.2 Power Supply Specifications

**Table 3.2: Power Supply Specifications**

Item	Description	
	FX2N-32DP-IF (AC Power Supply Type)	FX2N-32DP-IF-D (DC Power Supply Type)
Power Supply	100 ~ 240 V AC +10% -15%, 50/60 Hz	24 V DC +20% -30%
Max. Allowable Momentary Power Failure Period	10 ms at 100 V AC ( < 10 ms, 32DP-IF = RUN continue, > 10 ms, 32DP-IF = power down)	5 ms at 24 V DC ( < 5 ms, 32DP-IF = RUN continue, > 5 ms, 32DP-IF = power down)
Fuse (size) Rating	3.15 A <φ 5 × 20 mm (0.2 × 0.79 inches), Time lag fuse>	1 A <φ 5 × 20 mm (0.2 × 0.79 inches), Time lag fuse>
In-rush Current	100 V AC Max. 40 A < 5 ms, 200 V AC Max. 60 A < 5 ms	24 V DC Max. 30 mA < 5 ms
Power Consumption	30 VA	14W
24 V DC Service Supply	500 mA	-
Max. 5 V DC Bus Supply	220 mA	

### 3.3 Performance Specifications

**Table 3.3: Performance Specifications**

Items		Specifications
Maximum Number of Controllable I/O Points		Maximum 256 points (see section 1.3)
Transmission data (Exchange data length)		Max.200 bytes, total of sent and received during one bus cycle. (input: Max. 200 bytes, output: Max. 200 bytes)
Transmission Type		Bus network
Port	9 pin D-SUB	Port for Profibus-DP network
	8 pin mini DIN	Port for FX-20P-E or personal computer (MELSEC MEDOC PLUS)
Supported Baud Rates (bps) and Bus Length	9.6k, 19.2k, 45.45k, 93.75k	1,200 m (3,937')
	187.5k	1,000 m (3,281')
	500k	400 m (1,312')
	1.5M	200 m (656')
	3M, 6M, 12M	100 m (328')
LED Indicators	POWER LED	ON when power is supplied.
	RUN LED	ON when 32DP-IF is exchanging data with extension I/O blocks/ units and special function blocks.
	BF LED	ON when a communication error is detected. (No data exchange)
	DIA LED	ON when notice of diagnostic data is detected.

# MEMO

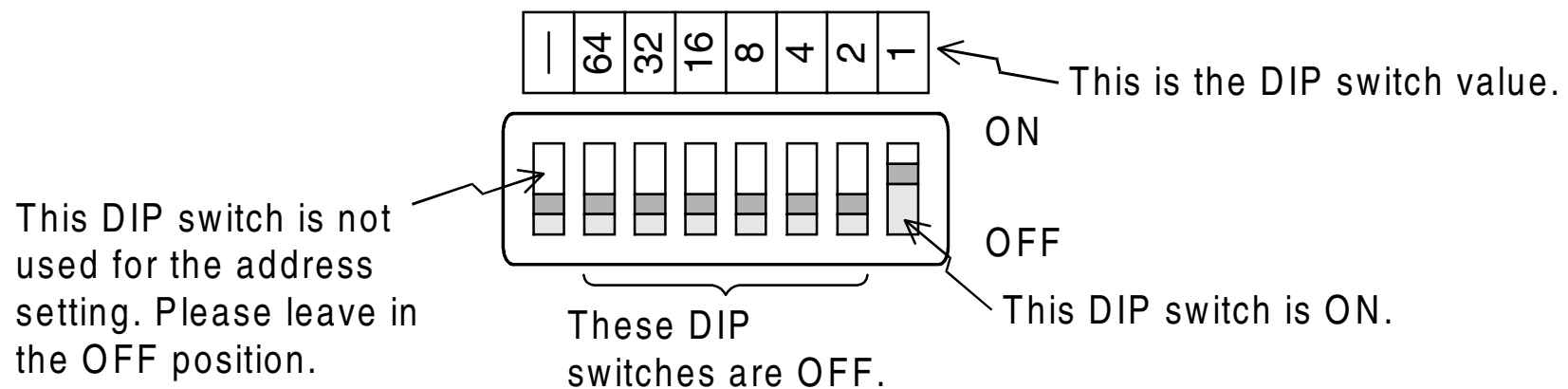


## 4. Address Setting

### 4.1 Setting the Address

The slave address of 32DP-IF for Profibus network is set by the ON/OFF configuration of DIP switches. Slave address setting range is 0 ~ 126. When 32DP-IF's power supply is turned ON, the slave address is the sum total of these DIP switch values.

**Figure 4.1: DIP Switches**



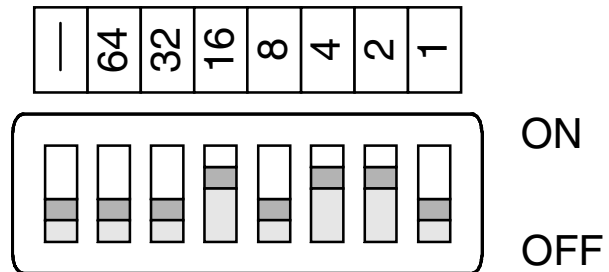
#### Note:

If the address of 32DP-IF is changed, the 32DP-IF must be turned OFF and ON again in order to activate the new address.

## 4.2 Example Address Setting

If slave address of 32DP-IF is set to “22”, the DIP switches are as shown below.

**Figure 4.2: Address Setting**



## 5. Diagnostics

### 5.1 Preliminary Checks

- 1) Check "POWER LED". If this is OFF, please see section 5.2.
- 2) Check that the slave address is the same at the 32DP-IF and the DP-master configuration. If the slave address is not the same in the 32DP-IF and in the DP-master, change this address to match in both modules.
- 3) Check that the parameter data of 32DP-IF are set correctly in the DP-master. If the parameter data of the 32DP-IF are not set correctly in the DP-master, communication over the Profibus-DP network may be affected.
- 4) Check whether the network wiring and/or the cables for the extension blocks/units are properly connected to the 32DP-IF.
- 5) Check that the system configuration rules have not been exceeded, i.e. the number of special function blocks does not exceed 8 and control I/O of 32DP-IF is 256 or less.
- 6) Put RUN/STOP switch on the 32DP-IF into RUN.

## 5.2 Check the Status of the LEDs of the 32DP-IF

If the 32DP-IF does not seem to operate normally, check the following items.  
For error flags, error codes, and device explanation, refer to FX2N-32DP-IF User's Manual.

1) Check the status of the "POWER LED".

**Table 5.1: POWER LED Check**

Status	Description
Lit	Power source is OK.
Unlit	Possible AC or DC power failure, check power line and power source.

2) Check the status of the "RUN LED"

**Table 5.2: RUN LED Check**

Status	Description
Lit	The 32DP-IF will exchange data with extension units/blocks and special function blocks.
Unlit	The 32DP-IF will exchange only input data with extension units/blocks. Check position of the RUN/STOP switch. If the switch is in the STOP position, change to RUN.

## 3) Check the status of the “BF LED”

**Table 5.3: BF LED Check**

Status	Description
Lit	Check D8024. If D8024 does not show a stable baud rate (i.e. always changing) then check DP-network cables. Check M8004. If M8004 is ON, refer to FX <sub>2N</sub> -32DP-IF User's Manual.
Unlit	32DP-IF will exchange data with profibus-DP network.

## 4) Check the status of the “DIA LED”

**Table 5.4: DIA LED Check**

Status	Description
Lit	Check status of M8004, and DP-master setting. If M8004 is ON, refer to FX <sub>2N</sub> -32DP-IF User's Manual.
Unlit	Diagnostic data is not detected.

# MEMO

## Appendix A: Further Information Manual Lists

**Table A-1: Further Information Manual Lists**

Manual name	Manual No.	Description
FX <sub>2N</sub> Series Programmable Controllers Hardware Manual	JY992D66301	This manual contains explanations for wiring, installation and specification, etc. about FX <sub>2N</sub> Series programmable controller.
FX <sub>0</sub> /FX <sub>0N</sub> Series Programmable Controllers Hardware Manual	JY992D47501	This manual contains explanations for wiring, installation and specification, etc. about FX <sub>0</sub> and FX <sub>0N</sub> Series programmable controllers.
FX <sub>2N</sub> -32DP-IF Profibus-DP Interface Unit User's Manual	JY992D79401	This manual contains explanations for wiring, installation, specification and BFM allocation, etc. about FX <sub>2N</sub> -32DP-IF Profibus-DP Interface Unit. However, the hardware manual's text is already contained in the user's manual.
FX <sub>2N</sub> -2DA Special Function Block User's Guide	JY992D74901	This manual contains explanations for wiring, installation, specification and BFM allocation, etc. about FX <sub>2N</sub> -2DA special function block.
FX <sub>2N</sub> -2AD Special Function Block User's Guide	JY992D74701	This manual contains explanations for wiring, installation, specification and BFM allocation, etc. about FX <sub>2N</sub> -2AD special function block.
FX <sub>0N</sub> -3A Special Function Block User's Guide	JY992D49001	This manual contains explanations for wiring, installation, specification and BFM allocation, etc. about FX <sub>0N</sub> -3A special function block.

**Table A-1: Further Information Manual Lists**

Manual name	Manual No.	Description
FX <sub>2N</sub> -4DA Special Function Block User's Guide	JY992D65901	This manual contains explanations for wiring, installation, specification and BFM allocation, etc. about FX <sub>2N</sub> -4DA special function block.
FX <sub>2N</sub> -4AD Special Function Block User's Guide	JY992D65201	This manual contains explanations for wiring, installation, specification and BFM allocation, etc. about FX <sub>2N</sub> -4AD special function block.
FX <sub>2N</sub> -4AD-PT Special Function Block User's Guide	JY992D65601	This manual contains explanations for wiring, installation, specification and BFM allocation, etc. about FX <sub>2N</sub> -4AD-PT special function block.
FX <sub>2N</sub> -4AD-TC Special Function Block User's Guide	JY992D65501	This manual contains explanations for wiring, installation, specification and BFM allocation, etc. about FX <sub>2N</sub> -4AD-TC special function block.
FX <sub>2N</sub> -1HC Special Function Block User's Guide	JY992D65401	This manual contains explanations for wiring, installation, specification and BFM allocation, etc. about FX <sub>2N</sub> -1HC special function block.
FX-1PG/FX <sub>2N</sub> -1PG Pulse Generation Unit User's Manual	JY992D65301	This manual contains explanations for wiring, installation, specification and BFM allocation, etc. about FX-1PG/FX <sub>2N</sub> -1PG Pulse Generation Unit.
FX <sub>2N</sub> -10GM User's Guide	JY992D77701	This manual contains explanations for specification about FX <sub>2N</sub> -10GM Positioning Control Unit. However, the user's guide's text is already contained in the hardware/programming manual.



**Table A-1: Further Information Manual Lists**

Manual name	Manual No.	Description
FX <sub>2N</sub> -20GM User's Guide	JY992D77601	This manual contains explanations for specification about FX <sub>2N</sub> -20GM Positioning Control Unit. However, the user's guide's text is already contained in the hardware/programming manual.
FX <sub>2N</sub> -10GM, FX <sub>2N</sub> -20GM Hardware/Programming Manual	JY992D77801	This manual contains explanations for wiring, installation, specification, parameter, instruction and BFM allocation, etc. about FX <sub>2N</sub> -10GM and FX <sub>2N</sub> -20GM Positioning Control Unit. However, these user's guide's text is already contained in the hardware/programming manual.
FX <sub>2N</sub> -32ASI-M AS-interface Master Block User's Manual	JY992D76901	This manual contains explanations for wiring, installation, specification and BFM allocation, etc. about FX <sub>2N</sub> -32ASI-M AS-interface Master Block
FX <sub>2N</sub> -232IF RS-232C Interface Block Hardware Manual	JY992D73501	This manual contains explanations for wiring, installation and specification, etc. about FX <sub>2N</sub> -232IF RS-232C Interface Block. For BFM allocation and example program, please see FX Communication (RS232C, RS485) User's Manual.
FX <sub>2N</sub> -8AD Analog Input Block User's Manual	JY992D86001	This manual contains explanation for wiring, installation, specification and BFM allocation, etc. about FX <sub>2N</sub> -8AD special function block.
FX <sub>2N</sub> -2LC User's Manual	JY992D85801	This manual contains explanation for wiring, installation, specification and BFM allocation, etc. about FX <sub>2N</sub> -2LC special function block.

**Table A-1: Further Information Manual Lists**

Manual name	Manual No.	Description
FX <sub>2N</sub> -10PG User's Manual	JY992D85801	This manual contains explanation for wiring, installation, specification and BFM allocation, etc. about the FX <sub>2N</sub> -10PG Pulse Generation Unit.
FX Communication (RS232C, RS485) User's Manual	JY992D69901	This manual contains explanations for N:N network, parallel link and computer link no protocol communication (RS instruction and FX <sub>2N</sub> -232IF RS232C interface block) about FX family PLC.
MELSEC ProfiMap Configuration System for Open Networks Software Manual	-	This manual contains explanations for operation of MELSEC ProfiMap Configuration System for Open Networks Software.

## Appendix B: Update History of FX<sub>2N</sub>-32DP-IF and GSD File

**Table B-1: Update History of FX<sub>2N</sub>-32DP-IF and GSD File**

Version		Contents
32DP-IF Hardware	GSD File	
V1.00	V1.00	First Product Supports the following unit / block. <ul style="list-style-type: none"> <li>• Special function blocks: FX<sub>2N</sub>-4AD, FX<sub>2N</sub>-4AD-TC, FX<sub>2N</sub>-4AD-PT, FX<sub>2N</sub>-4DA</li> <li>• Extension units: FX<sub>2N</sub>-32ER-ES/UL, FX<sub>2N</sub>-32ET-ESS/UL, FX<sub>2N</sub>-48ER-ES/UL, FX<sub>2N</sub>-48ET-ESS/UL, FX<sub>2N</sub>-48ER-UA1/UL</li> <li>• Extension blocks: FX<sub>2N</sub>-16EX-ES/UL, FX<sub>2N</sub>-16EYR-ES/UL, FX<sub>2N</sub>-16EYT-ESS/UL, FX<sub>0N</sub>-8EX-UA1/UL, FX<sub>0N</sub>-8EX-ES/UL, FX<sub>0N</sub>-8ER-ES/UL, FX<sub>0N</sub>-8EYR-ES/UL, FX<sub>0N</sub>-8EYT-ESS/UL, FX<sub>0N</sub>-16EX-ES/UL, FX<sub>0N</sub>-16EYR-ES/UL, FX<sub>0N</sub>-16EYT-ESS/UL</li> </ul>
V1.10	V1.10	Supports FX <sub>0N</sub> -3A, FX <sub>2N</sub> -2AD, FX <sub>2N</sub> -2DA, FX <sub>2N</sub> -1HC, FX <sub>2N</sub> -1PG, FX <sub>2N</sub> -10GM, FX <sub>2N</sub> -20GM, FX <sub>2N</sub> -32ASI-M and FX <sub>2N</sub> -232IF.

**Table B-1: Update History of FX2N-32DP-IF and GSD File**

Version		Contents
32DP-IF Hardware	GSD File	
V2.00	V2.00	Supports the swap parameter (Second byte bit 4 in the global user parameter). (Further information can be found in the FX2N-32DP-IF User's Manual.)
V2.10	V2.10	Supports the following <ul style="list-style-type: none"><li>• Profibus-DP Interface unit: FX2N-32DP-IF-D</li><li>• Special function blocks: FX2N-8AD, FX2N-2LC, FX2N-10PG.</li><li>• Extension units: FX2N-48ER-DS, FX2N-48ET-DSS</li></ul>



# HARDWARE MANUAL

FX<sub>2</sub>N-32DP-IF Profibus-DP Interface Unit



HEAD OFFICE: TOKYO BUILDING, 2-7-3 MARUNOUCHI, CHIYODA-KU, TOKYO 100-8310, JAPAN  
HIMEJI WORKS: 840, CHIYODA CHO, HIMEJI, JAPAN

---

JY992D77101E  
(MEE)

Effective Nov. 2008  
Specification are subject  
to change without notice.