

Table with columns for Country/Region, Sales office, Tel/Fax, and USA, Germany, China, Korea.

2. About safety This chapter explains safety of users and machine operators. Please read the chapter carefully before mounting the equipment. In this installation guide, the specific warnings and cautions levels are classified as follows.

WARNING and CAUTION icons with their respective meanings regarding handling and safety.

2.1 Professional engineer Only professional engineers should mount this to MR-J4 servo amplifiers. Here, professional engineers should meet all the conditions below.

- (1) Persons who took a proper training of related work of electrical equipment or persons who can avoid risk based on past experience. (2) Persons who have read and familiarized himself/herself with this installation guide and operating manuals for the protective devices (e.g. light curtain) connected to the safety control system.

2.2 Applications of the devices MR-D30 has a control system whose configuration is possible to be for safety. This product complies with the following standards. (Declaration of conformity No. BCN-B61008-076) EN ISO 13849-1 Category 3 PL d and Category 4 PL e

2.3 Correct use CAUTION MR-D30 complies with basic specifications concerning radiation electromagnetic immunity and fulfills requirements of industrial uses. Therefore, MR-D30 is only for use in industrial environment, not for general use.

MR-D30 can be used only within specifications. (Refer to section 6.2 and section 6.3.) Only professional engineer can use the control system in which MR-D30 is integrated. Additionally, only when a professional engineer installed, performed test operations, and adjusted a machine following "MR-D30 Instruction Manual", an operator can use the machine.

2.3.1 EU compliance The combination of MR-J4 servo amplifier and MR-D30 is designed to comply with the following directions to meet requirements for mounting, using, and periodic technical inspections: Machinery directive (2006/42/EC), EMC directive (2014/30/EU), and Low-voltage directive (2014/35/EU).

- (1) EMC requirement The combination of MR-J4 servo amplifier and MR-D30 complies with category C3 in accordance with EN 61800-3. As for I/O wires (max. length 10 m) and encoder cables (max. length 50 m), use shielded wires and ground the shields. Use an EMC filter and surge protector on the primary side. The following shows recommended products. EMC filter: Soshin Electric HF3000A-UN series. Surge protector: Okaya Electric Industries RSPD-250-U4 series MR-J4 Series are not intended to be used on a low-voltage public network which supplies domestic premises; radio frequency interference is expected if used on such a network. The installer shall provide a guide for installation and use, including recommended mitigation devices. To avoid the risk of crosstalk to signal cables, the installation instructions shall either recommend that the power interface cable be segregated from signal cables. (2) For Declaration of Conformity (DoC) Hereby, MITSUBISHI ELECTRIC EUROPE B.V., declares that the servo amplifier with MR-D30 is in compliance with the necessary requirements and standards (2006/42/EC, 2014/30/EU and 2014/35/EU). For the copy of Declaration of Conformity, contact your local sales office.

2.3.2 USA/Canada compliance The servo amplifiers on which MR-D30 is mounted are designed in compliance with UL 508C and CSA C22.2 No. 14.

- (1) Installation The minimum cabinet size is 150% of each MR-J4 servo amplifier's volume including MR-D30. Also, design the cabinet so that the ambient temperature in the cabinet is 55 °C or less. The servo amplifiers on which MR-D30 is mounted must be installed in a metal cabinet. For environment, the units should be used in open type (UL 50) and overvoltage category III or lower. MR-D30 and servo amplifier needs to be installed at or below of pollution degree 2. For connection, use only copper wires. (2) Short-circuit current rating (SCCR) Each servo amplifier on which MR-D30 is mounted has checked with a short-circuit test. (3) Overload protection characteristics The servo amplifier on which MR-D30 is mounted has servo motor overload protective function. (It is set on the basis (full load current) of 120% rated current of the servo amplifier.) (4) Over-temperature protection for motor Motor Over temperature sensing is not provided by the drive. Integral thermal protection is necessary for motor and refer to chapter 4 for the proper connection. (5) Capacitor discharge It takes 15 minutes for capacitor discharging of the servo amplifier on which MR-D30 is mounted. Do not touch the unit and terminals immediately after power off. (6) Branch circuit protection For installation in United States, branch circuit protection must be provided, in accordance with the National Electrical Code and any applicable local codes. For installation in Canada, branch circuit protection must be provided, in accordance with the Canada Electrical Code and any applicable provincial codes.

2.3.3 South Korea compliance This product complies with the Radio Wave Law (KC mark). Please note the following to use the product. 이 기기는 업무용 (A급) 전자파적합기기로서 판매자 또는 사용자는 이 점을 주의하시기 바라며, 가전취외지역에서 사용하는 것을 목적으로 합니다. (The product is for business use (Class A) and meets the electromagnetic compatibility requirements. The seller and the user must note the above point, and use the product in a place except for home.)

2.4 Safety observation function compatible unit The safety observation function is executed by writing a parameter to MR-D30 in a system using an MR-J4 servo amplifier, motion CPU and safety programmable controller in the following table. Set the parameters of MR-D30 correctly for a proper operation of the safety observation function. Protective functions such as the safety observation function may not work due to an incorrect setting. Refer to "MR-D30 Instruction Manual" for the parameter setting details.

Table listing safety observation function compatible units, including servo amplifier, motion CPU module, MR-D30 software version, servo amplifier software version, safety observation function, servo motor with functional safety, and servo amplifier.



Table for Motion controller with columns Model, OS, Software version. Rows Q173DSCPU, Q172DSCPU, SW8DNC-SV22QJ/SW8DNC-SV13QJ, SW8DNC-SV22QL/SW8DNC-SV13QL, OS or later.

2.5 General cautions for safety protection and protective measures POINT Observe the cautions for safety protection and protective measures. Observe the items of this section for proper use of MR-D30.

- (1) When mounting, installing, and using the MR-D30, always observe standards and directives applicable in the country. (2) When using an MR-D30 in an EU member state, comply with the following directives. • Machinery directive 2006/42/EC • EMC directive 2014/30/EU • Low-voltage directive 2014/35/EU • Other laws/regulations of labor safety (3) The manufacturer and owner of machines on which an MR-D30 is used should be familiarized with all the applicable laws and regulations and should be responsible to observe them. For Declaration of Conformity (DoC), our company declares that the servo amplifiers are in compliance with the necessary requirements and standards (2006/42/EC, 2014/30/EU and 2014/35/EU). You can obtain the copy of Declaration of Conformity from our website. (4) The contents of "MR-D30 Instruction Manual" must be observed. (5) Tests should be performed by professional engineers, especially qualified and responsible personnel, and should be recorded/documented for a third party to rebuild and confirm the tests. (6) An external power supply of equipment should have resistance to instantaneous power failure for 20 ms according to the specifications of IEC/EN 60204-1.

2.6 Disposal Disposal of unusable or irreparable devices should always occur in accordance with the applicable country-specific waste disposal regulations. (Example: European Waste 16 02 14) 2.7 Risk assessment To ensure safety, users should decide all the risk assessments and residual risks in the entire machine equipment. A company and/or individual who constructed the safety related system must take full responsibility for installation and commissioning of the system. Additionally, when complying with a European machinery directive, the system must acquire safety standards certification as a whole. Perform all risk assessments and safe level certification to the machine or the system as a whole. It is recommended that a Certification Body final safety certification of the system be used. The following shows residual risks concerning the safety observation function of this product.

- 2.7.1 Common residual risks in each function (1) At the shipment to end-users, check the settings of safety related components with programming tools and monitored/displayed contents on display and record and save the setting data concerning the safety observation function and the programming tools you used. Perform them using a check sheet, etc. (2) The safety will not be ensured such as in assembling machine until installing, wiring, and adjustment are completed properly. Install, wire, and adjust your system referring to installation guide for each unit. (3) Only qualified personnel are authorized to install, start-up, repair or adjust the machines in which these components are installed. Only trained engineers should install and operate the equipment. (ISO 13849-1 Table F.1 No. 5) (4) Separate the wiring for safety observation function from other signal wirings. (ISO 13849-1 Table F.1 No. 1) (5) Protect the cables with appropriate ways (routing them in a cabinet, using a cable guard, etc.). (6) We recommend using a switch, relay, sensor, etc. which comply with safety standards. When using a switch, relay, sensor, etc. which do not comply with safety standards, perform a safety confirmation. (7) Keep the required clearance/creepage distance depending on voltage you use. (8) The time to a safety observation error depends on parameter settings.

- 2.7.2 Residual risks in each function (1) Speed monitoring (SLS) (a) Speed monitoring function guarantees the servo motor speed, but it does not guarantee the actual machine speed. Set parameters so that the safe speed of the machine is the same as the safety speed of the specified motor. (b) Check if the speed of the monitored servo axis is the same as the actual speed by using a tachometer, etc. considering the speed includes an error caused by the command and encoder resolution. (c) The defect of the mechanical section such as slid of shaft and winding of a timing belt, etc. is not covered. Be sure to eliminate the risk of mechanical section before operation. (d) Speed monitoring error detection time is set to 1 ms. Error in shorter than this time are not detected. (e) After speed is over the limit, safety observation error (shut-off signal off) does not occur during the speed error detection time set by the parameter. Make sure that safety can be ensured during this period. (2) Safe speed monitor (SSM) When SSM is used as a restart trigger, perform it according to IEC/EN 60204-1. (3) Safe brake control (SBC) This function guarantees only that power to mechanic break is properly supplied and abrasion of the brake cannot be detected. Check this function regularly that the mechanic brake can operate.

3. Conditions of use for the product (1) MR-D30 complies with a safety standard, but this fact does not guarantee that MR-D30 will be free from any malfunction or failure. The user of this product shall comply with any and all applicable safety standard, regulation or law and take appropriate safety measures for the system in which the product is installed or used and shall take the second or third safety measures other than the product. Our company is not liable for damages that could have been prevented by compliance with any applicable safety standard, regulation or law.

- (2) Our company prohibits the use of Products with or in any application involving, and we shall not be liable for a default, a liability for defect warranty, a quality assurance, negligence or other tort and a product liability in these applications. (a) Power plants (b) Trains, railway systems, airplanes, airline operations, and other transportation systems (c) Hospitals, medical care, dialysis and life support facilities or equipment (d) Amusement equipment (e) Incineration and fuel devices (f) Handling of nuclear or hazardous materials or chemicals (g) Mining and drilling (h) Other applications where the level of risk to human life, health or property are elevated.

4. Block diagram and timing chart (1) Function block diagram (for using input signal) This is an example of a combination with MR-J4_ B_ RJ.

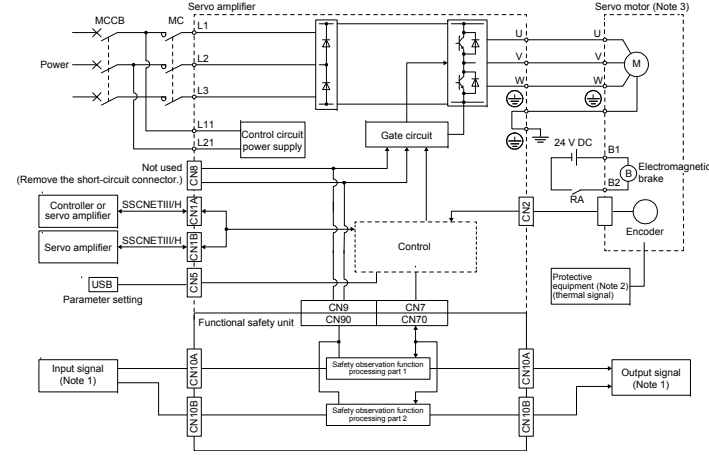

- Note 1. Safety switch, safety relay, etc. for thermal protection of the servo motor. 2. Please use a thermal sensor, etc. for thermal protection of the servo motor. 3. The HG-KR_WOC, HG-SR_WOC, or HG-JR_WOC servo motor is required to use the SS2/SOS functions.

(2) How to use the functions To use the safety observation functions, combine MR-D30 with MR-J4. For how to use the functions, refer to "MR-D30 Instruction Manual".

5. Maintenance and disposal MR-D30 safety logic unit is equipped with LED displays to check errors for maintenance. Please dispose this unit according to your local laws and regulations. Changing the combination of MR-D30 and MR-J4 servo amplifier will trigger [AL. 7A.4 Functional safety unit combination error (safety observation function)] and the safety observation function you set will not operate.

- 6. Functions and configuration 6.1 Summary (1) Safety observation functions are available with your servo amplifier. Mounting the functional safety unit to the servo amplifier enables you to use the safety observation functions such as STO/SS1/SS2/SOS/SL/S/SM/SBC without depending on a controller. (2) Compatible with safety integrated motion controller Safety communication with motion controllers is available by using MR-D30 with MR-J4_ B_ RJ. With this, the wiring which was required can be reduced for the STO signal and encoder signal for safety observation.

6.2 Transportation and storage CAUTION Transport the products correctly according to their mass. Stacking in excess of the limited number of product packages is not allowed. Install the equipment in a load-bearing place in accordance with "MR-D30 Instruction Manual". Do not put excessive load on the machine.

When you keep or use it, please fulfill the following environment.

Table for Environment with columns Item and Environment. Rows include Ambient temperature, Ambient humidity, Vibration resistance, Pollution degree, IP rating, and Altitude.

Note. In regular transport packaging

Table for Specifications with columns Model and MR-D30. Rows include Output, Interface power supply, Standards certified by CB, Mean time to dangerous failure, Safety performance, Response performance, Speed observation resolution, Position observation resolution, Output device, Safe torque off (STO), Safe stop 1 (SS1), Safety-limited speed (SLS), Safe speed monitor (SSM), Safe brake control (SBC), Safe operating stop (SOS), Safe stop 2 (SS2), Compliance to global standards, and Structure (IP rating).

- Note 1. This is the value applicable when all I/O signals are used. The current capacity can be decreased by reducing the number of I/O points. 2. Time from STO input off to energy shut off. 3. To meet Category 4, PL e, SIL 3 for input signals, a diagnosis using test pulses is required. 4. To meet Category 4, PL e, SIL 3, using with an HG-KR_WOC, HG-SR_WOC, or HG-JR_WOC servo motor is required. 5. To enable SS2 and SOS, using with an HG-KR_WOC, HG-SR_WOC, or HG-JR_WOC servo motor is required. 6. For the achievable safety level, refer to the section of "Safety observation function (IEC/EN 61800-5-2)". 7. Linear servo system, direct drive servo system, and fully closed loop system are not compatible with SLS, SSM, SS2, and SOS.

6.4 When using MR-D30 for an MR-J4 series servo amplifier 6.4.1 Input signal

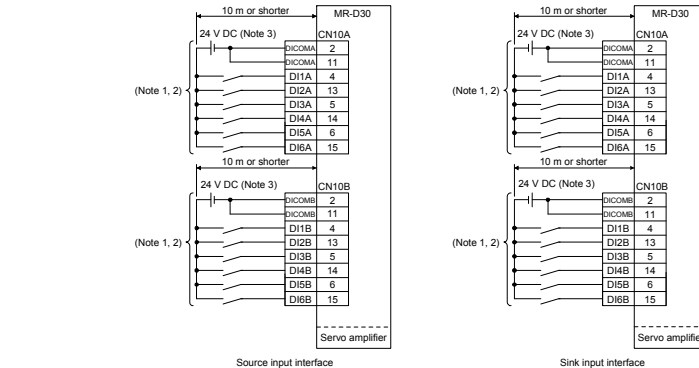

- Note 1. Separate all the external wires by two types, CN10A and CN10B. 2. Assign each input device to the following combinations of connector and pin. Refer to chapter 7 for each device. Combination of connector and pin for input DI1A (CN10A-4)/DI1B (CN10B-4) DI2A (CN10A-13)/DI2B (CN10B-13) DI3A (CN10A-5)/DI3B (CN10B-5) DI4A (CN10A-14)/DI4B (CN10B-14) DI5A (CN10A-6)/DI5B (CN10B-6) DI6A (CN10A-15)/DI6B (CN10B-15) 3. Supply 24 V DC ± 10% to interfaces from outside. When all the I/O points are used, the required current capacity is 0.8 A in total. The current capacity can be decreased by reducing the number of I/O points. Refer to section 7.2 that gives the current value necessary for the interface. The illustration of the 24 V DC power supply is divided between input signal and output signal for convenience. However, they can be configured by one.

